

Obrazová příloha



Obr.1 – reliéf z Neumagenu

Available from:

<http://www.germany.info/Vertretung/usa/en/04__W__t__G/04/04/01/Feature__1.html>.

[29 July 2013].

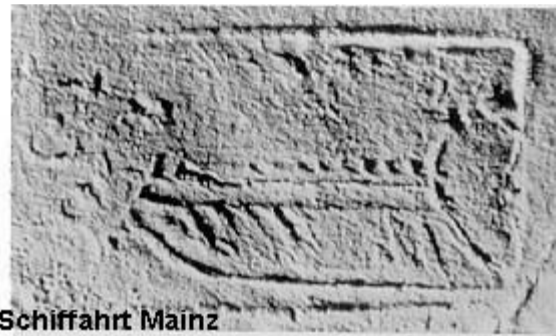
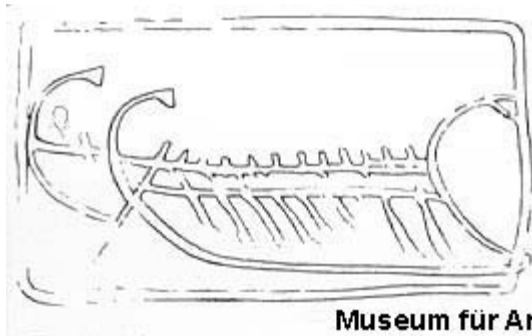

Museum für Antike Schifffahrt Mainz

Obr.2 – kolok na tehle XXII. légie z Mainzu

Available from: <<http://www2.rgzm.de/Navis/Home/NoFrames.htm>>. [27 July 2013].

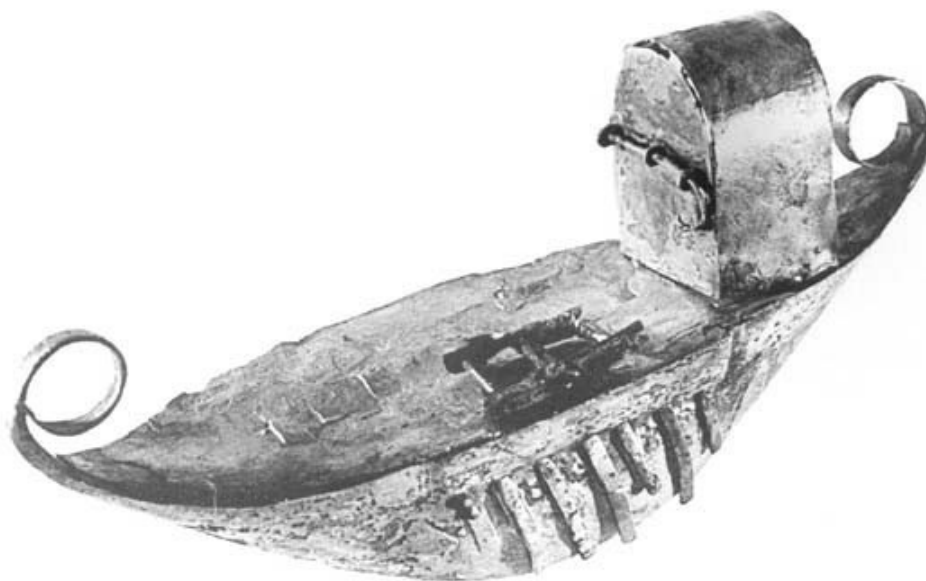

Obr.3 – model lode z Rethelu

Available from: < <http://www2.rgzm.de/Navis/Home/NoFrames.htm>>. [27 July 2013].



Obr.4 – lod' číslo 7 z Woerdenu

Available from: < <http://www.woerden7.nl/>>. [27 July 2013].



Obr.5 – lode číslo 1 a 2 z Oberstimmu

Available from: < <http://www2.rgzm.de/Navis/Home/NoFrames.htm>>. [27 July 2013].

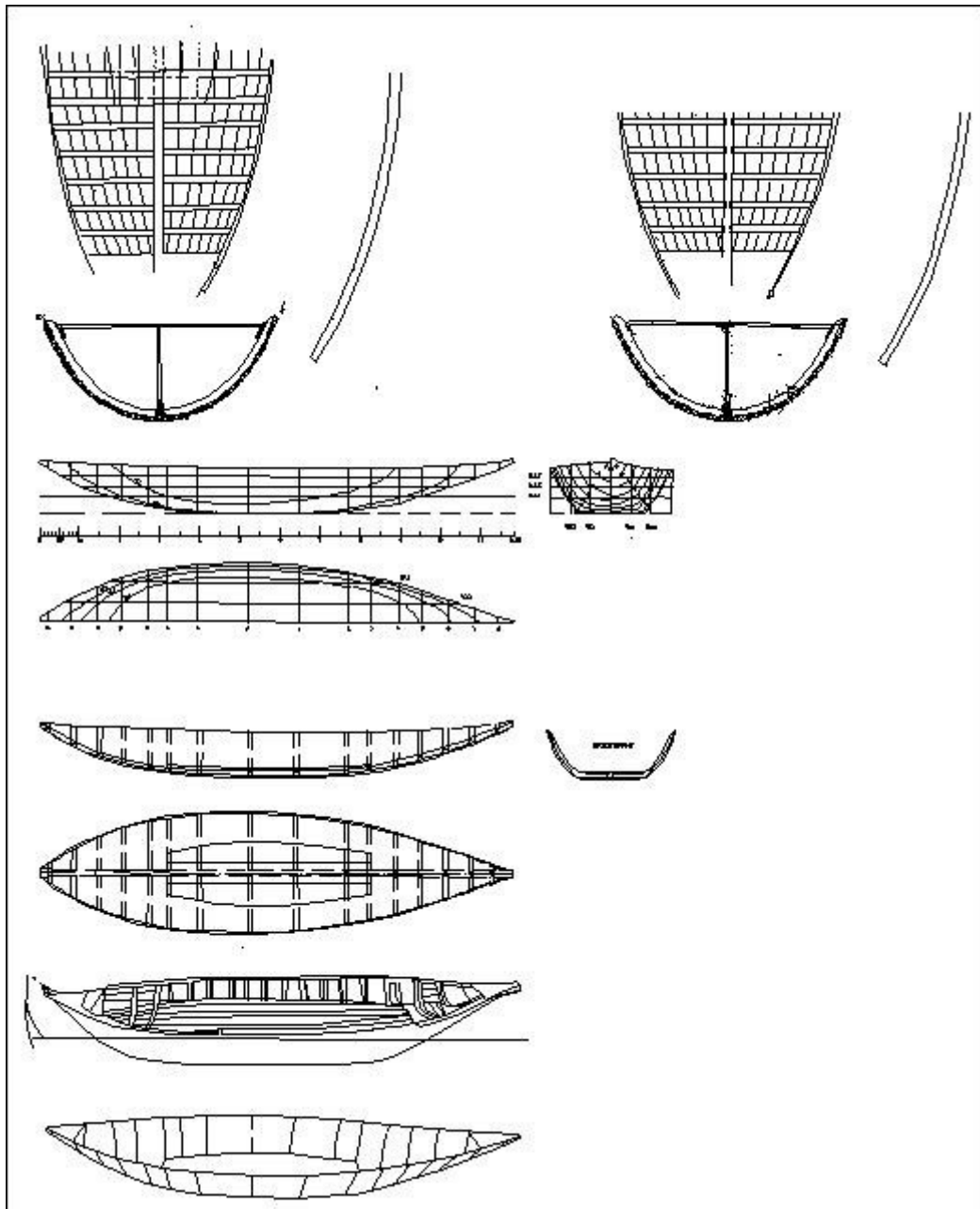

Obr.6 – rôzne rekonštrukcie lode z Vechtenu

Available from: < <http://www2.rgzm.de/Navis/Home/NoFrames.htm>>. [27 July 2013].

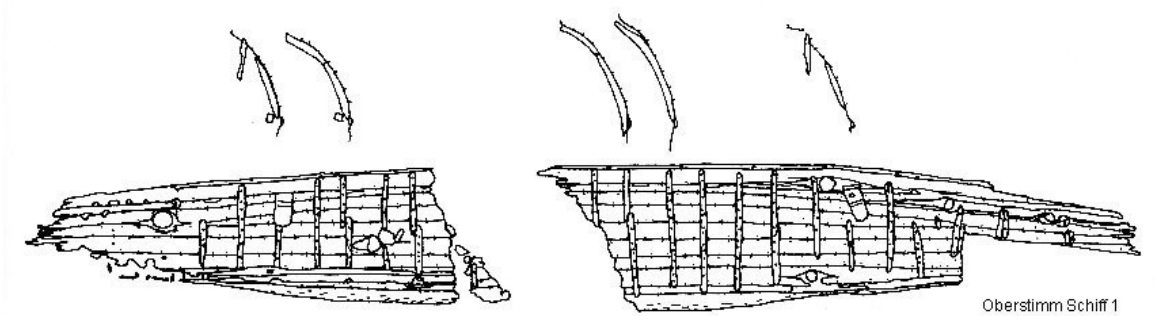

Obr.7 – lod' číslo 1 z Oberstimmu

Available from: < <http://www2.rgzm.de/Navis/Home/NoFrames.htm>>. [27 July 2013].

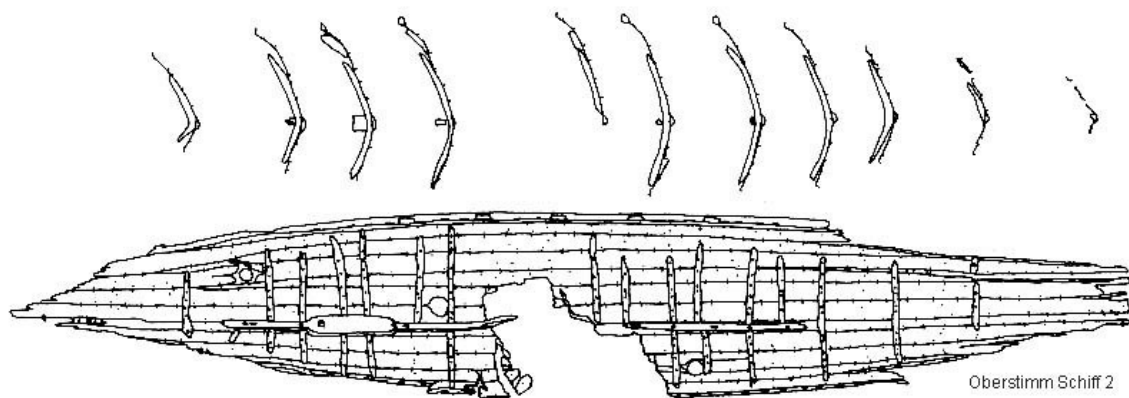

Obr.8 – lod' číslo 2 z Oberstimmu

Available from: < <http://www2.rgzm.de/Navis/Home/NoFrames.htm>>. [27 July 2013].



Obr.9 – model lode číslo 2 z Oberstimmu

Available from: < <http://www2.rgzm.de/Navis/Home/NoFrames.htm>>. [27 July 2013].



Obr.10 – čeleň modelu lode číslo 2 z Oberstimmu

Available from: < <http://www2.rgzm.de/Navis/Home/NoFrames.htm>>. [27 July 2013].

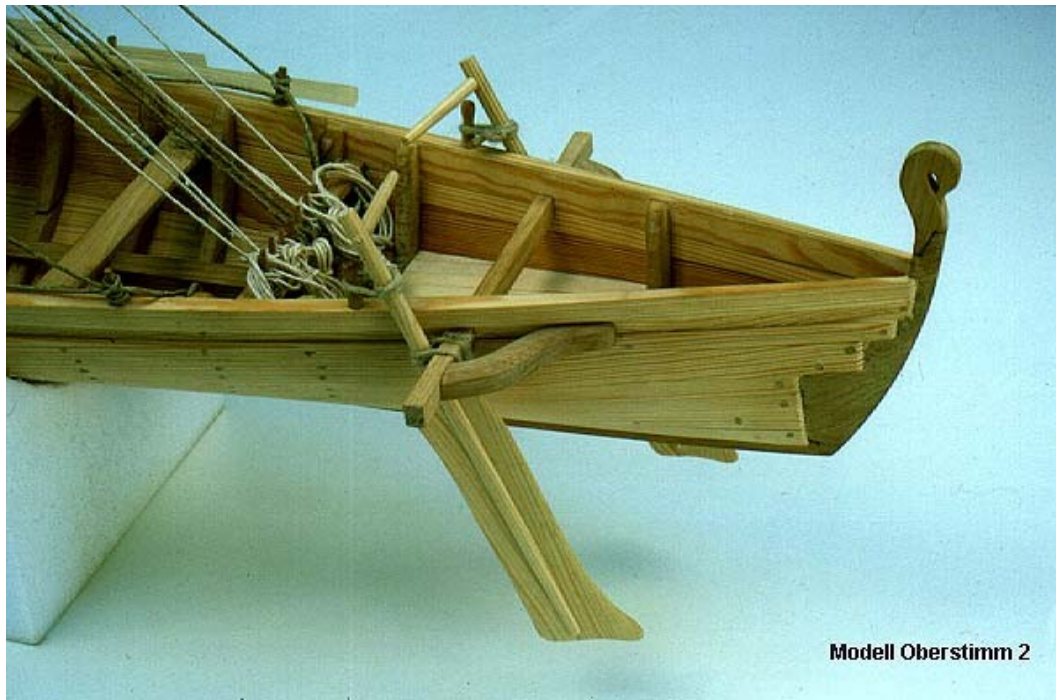

Obr.11 – kormovec modelu lode číslo 2 z Oberstimmu

Available from: < <http://www2.rgzm.de/Navis/Home/NoFrames.htm>>. [27 July 2013].

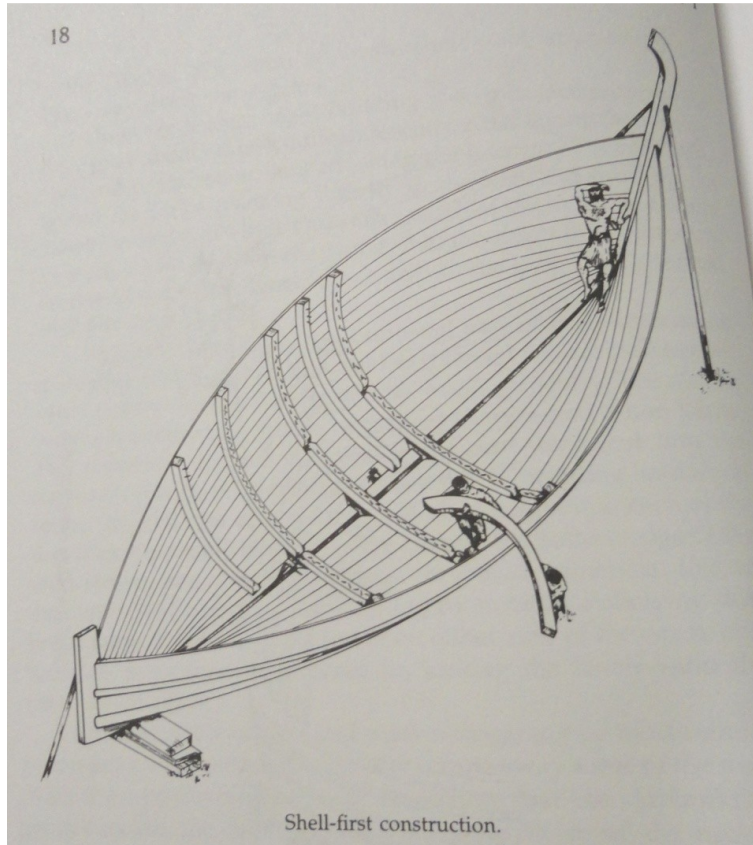

Obr.12 – grécko-rímsky spôsob stavby lodí

Available from: Wachsmann 1995, p.18

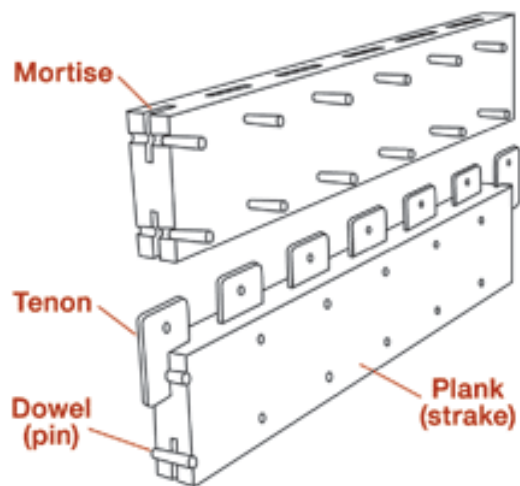

Obr.13 – tvorba obšívky trupu lode postavenej grécko-rímskym spôsobom

Available from:

<<http://www.answersingenesis.org/articles/am/v2/n2/thinking-outside-the-box>>.

[27 July 2013].

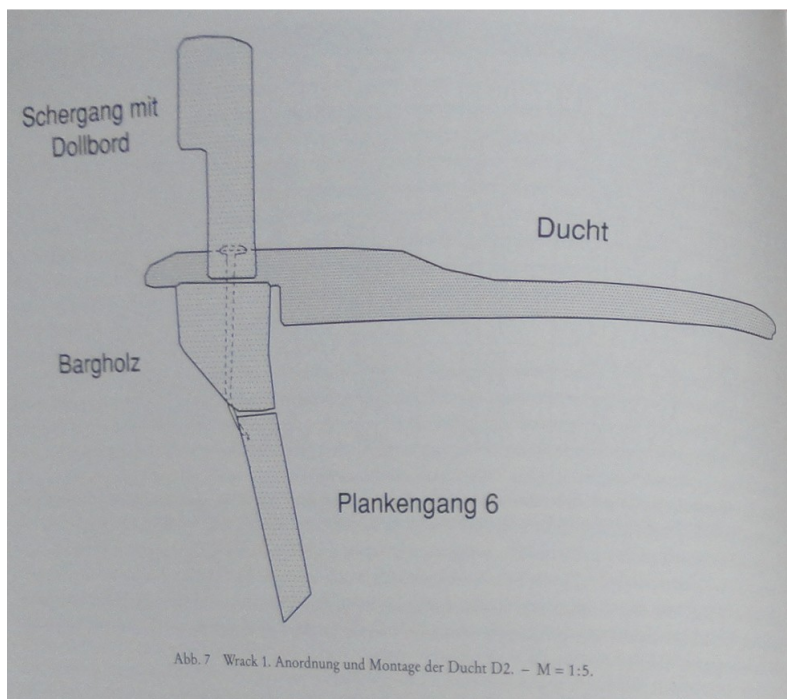

Obr.14 – okraj trupu lode číslo 1 z Oberstimmu

Available from: Bockius 2002, p.20

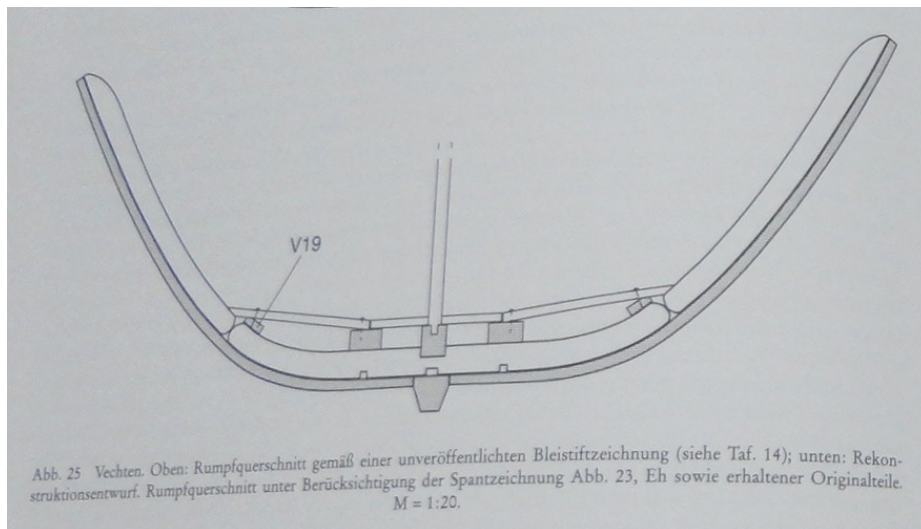

Obr.15 – pričný rez trupom lode z Vechtenu

Available from: Bockius 2002, p.118

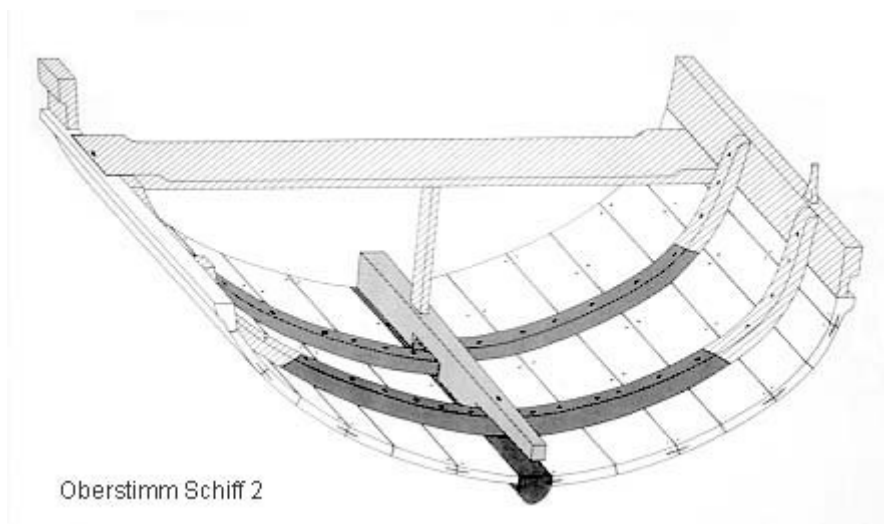

Obr.16 – rekonštrukcia upevnenia veslárskej lavice v lodi číslo 2 z Oberstimu

Available from: < <http://www2.rgzm.de/Navis/Home/NoFrames.htm>>. [27 July 2013].

Modell Oberstimm 2

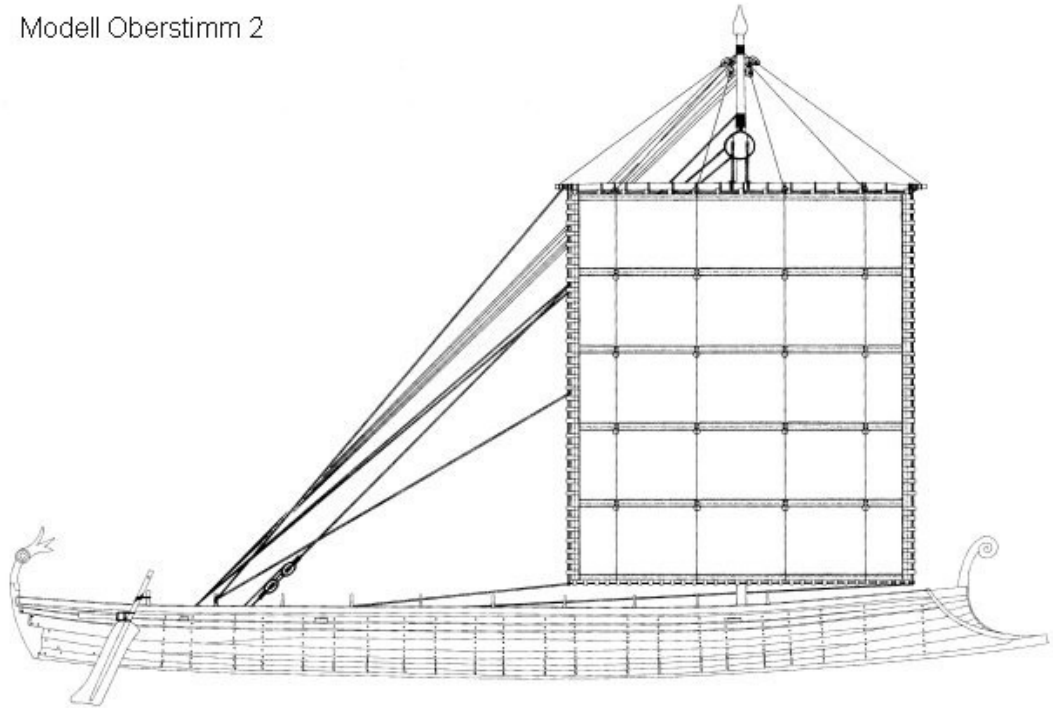

Obr.17 – rekonštrukcia oplachtenia lode číslo 2 z Oberstimmu

Available from: < <http://www2.rgzm.de/Navis/Home/NoFrames.htm>>. [27 July 2013].



Obr.18 – lod' číslo 2 z Zwammerdamu

Available from: < <http://www2.rgzm.de/Navis/Home/NoFrames.htm>>. [27 July 2013].



Obr.19 – loď číslo 6 z Zwammerdamu

Available from: < <http://www2.rgzm.de/Navis/Home/NoFrames.htm>>. [27 July 2013].



Obr.20 – chrbtica lode číslo 2 z Zwammerdamu

Available from: < <http://www2.rgzm.de/Navis/Home/NoFrames.htm>>. [27 July 2013].

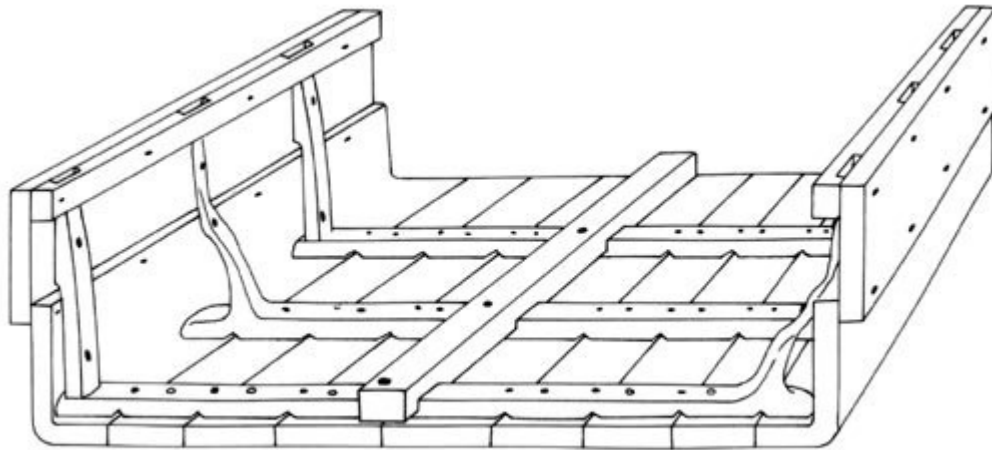

Obr.21 – priečny rez trupom lode číslo 2 z Zwammerdamu

Available from: < <http://www2.rgzm.de/Navis/Home/NoFrames.htm>>. [27 July 2013].

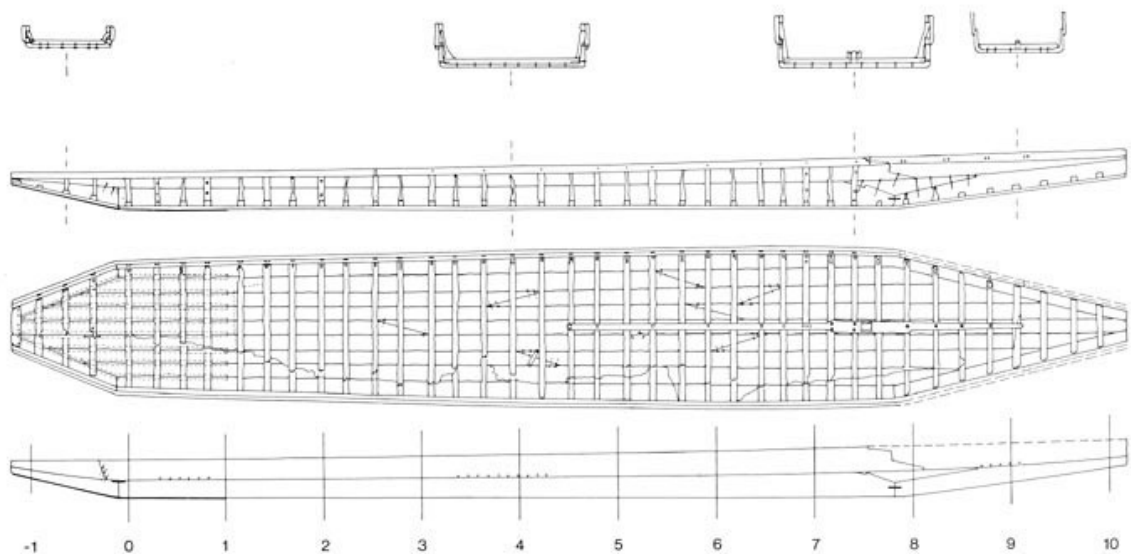

Obr.22 – plán lode číslo 2 z Zwammerdamu

Available from: < <http://www2.rgzm.de/Navis/Home/NoFrames.htm>>. [27 July 2013].

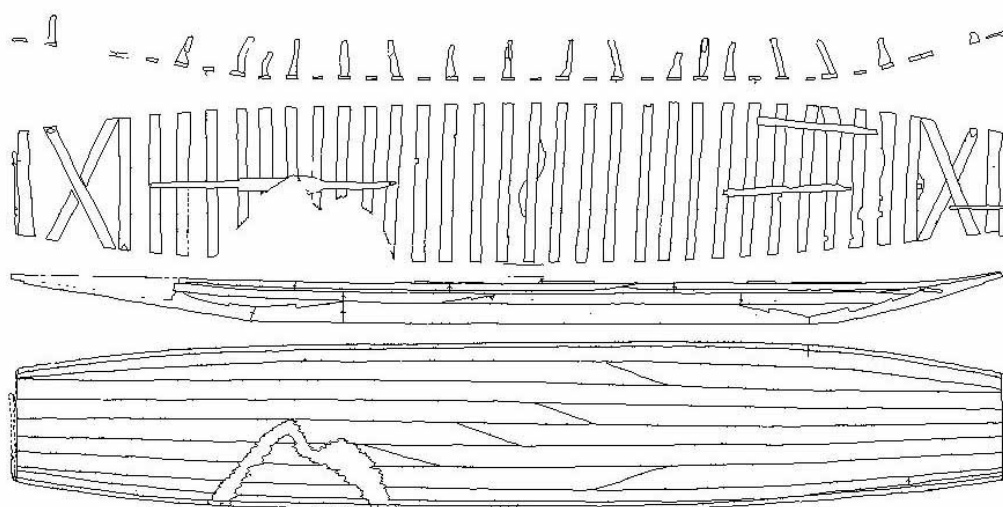

Zwammerdam 6

Obr.23 – plán trupu lode číslo 6 z Zwammerdamu

Available from: < <http://www2.rgzm.de/Navis/Home/NoFrames.htm>>. [27 July 2013].



Modell Mainz 8

Obr.24 – model lode číslo 6 z Mainzu

Available from: < <http://www2.rgzm.de/Navis/Home/NoFrames.htm>>. [27 July 2013].

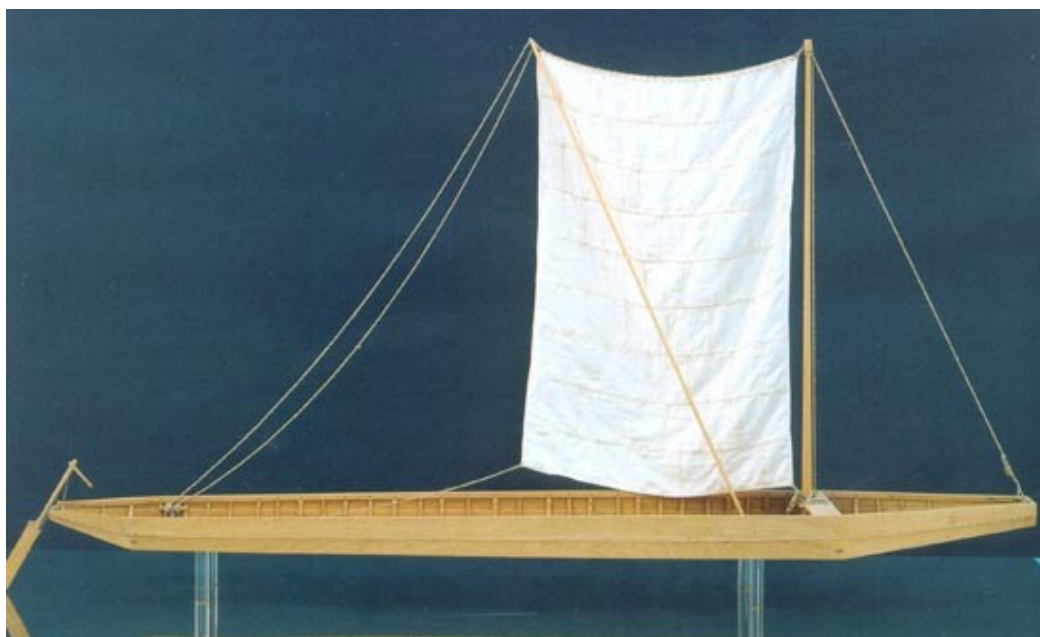

Obr.25 rekonštrukcia oplachtenia lode číslo 2 z Zwammerdamu

Available from: < <http://www2.rgzm.de/Navis/Home/NoFrames.htm>>. [27 July 2013].



Obr.26 – rekonštrukcia kormidlového systému lode číslo 6 z Mainzu

Available from: < <http://www2.rgzm.de/Navis/Home/NoFrames.htm>>. [27 July 2013].



Obr.27 – lod' číslo 1 z Mainzu

Available from: < <http://www2.rgzm.de/Navis/Home/NoFrames.htm>>. [27 July 2013].



Obr.28 – lod' číslo 2 z Mainzu

Available from: < <http://www2.rgzm.de/Navis/Home/NoFrames.htm>>. [27 July 2013].



Obr.29 – lod' číslo 4 z Mainzu

Available from: < <http://www2.rgzm.de/Navis/Home/NoFrames.htm>>. [27 July 2013].



Obr.30 – lod' číslo 5 z Mainzu

Available from: < <http://www2.rgzm.de/Navis/Home/NoFrames.htm>>. [27 July 2013].



Obr.31 – rekonštrukcia lode typu Mainz A

Available from: < <http://www2.rgzm.de/Navis/Home/NoFrames.htm>>. [27 July 2013].

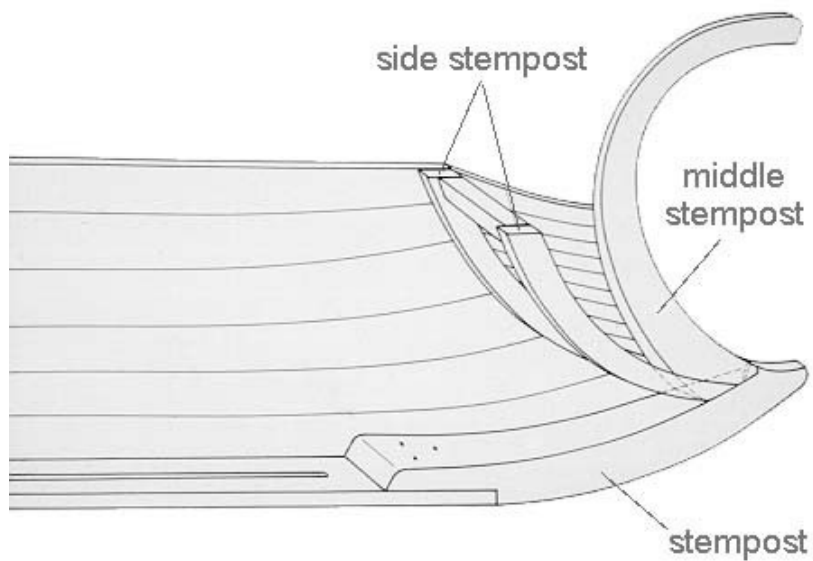

Obr.32 – stavba predného väzu lode typu Mainz A

Available from: < <http://www2.rgzm.de/Navis/Home/NoFrames.htm>>. [27 July 2013].



Obr.33 – rekonštrukcia kormovca lode typu Mainz A

Available from: < <http://www2.rgzm.de/Navis/Home/NoFrames.htm>>. [27 July 2013].

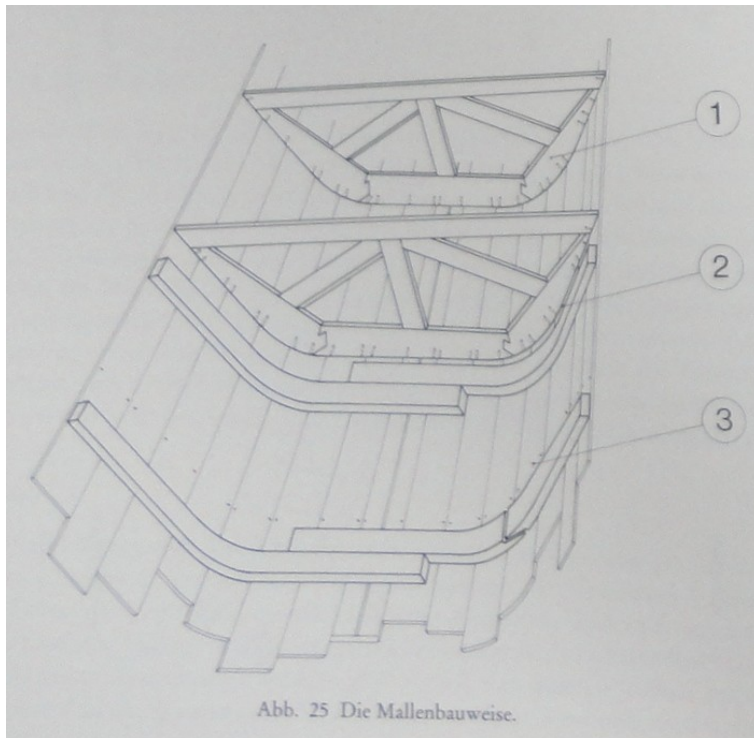

Obr.34 – použitie šablón pri stavbe lode typu Mainz A

Available from: Pferdehirt 1995, p.30

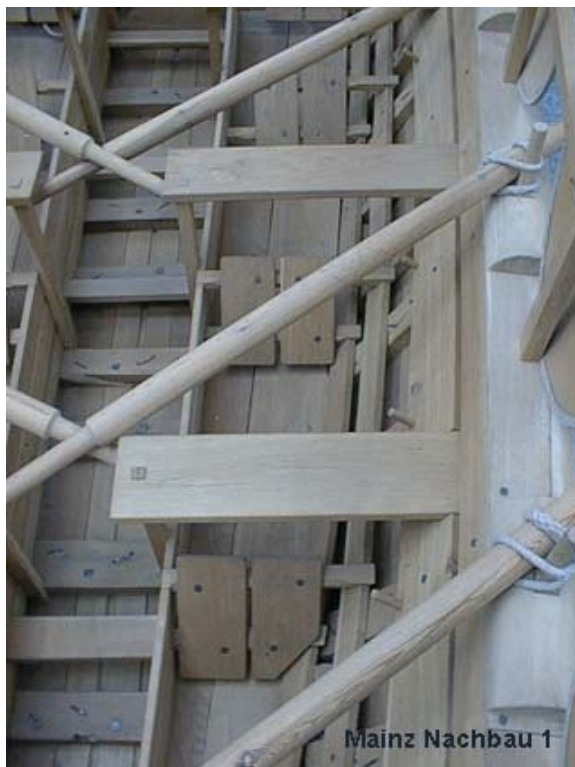

Obr.35 – rekonštrukcia veslárskoho systému lode typu Mainz A

Available from: < <http://www2.rgzm.de/Navis/Home/NoFrames.htm>>. [27 July 2013].



Obr.36 – rekonštrukcia kormidlového systému lode typu Mainz A

Available from: < <http://www2.rgzm.de/Navis/Home/NoFrames.htm>>. [27 July 2013].



Obr.37 – rekonštrukcia oplachtenia lode typu Mainz A

Available from: < <http://www2.rgzm.de/Navis/Home/NoFrames.htm>>. [27 July 2013].



Obr.38 – lod' číslo Mainz 3

Available from: < <http://www2.rgzm.de/Navis/Home/NoFrames.htm>>. [27 July 2013].



Obr.39 – rekonštrukcia lode typu Mainz 3

Available from: < <http://www2.rgzm.de/Navis/Home/NoFrames.htm>>. [27 July 2013].



Obr.40 – rekonštrukcia výložníka lode číslo 3 z Mainzu

Available from: < <http://www2.rgzm.de/Navis/Home/NoFrames.htm>>. [27 July 2013].

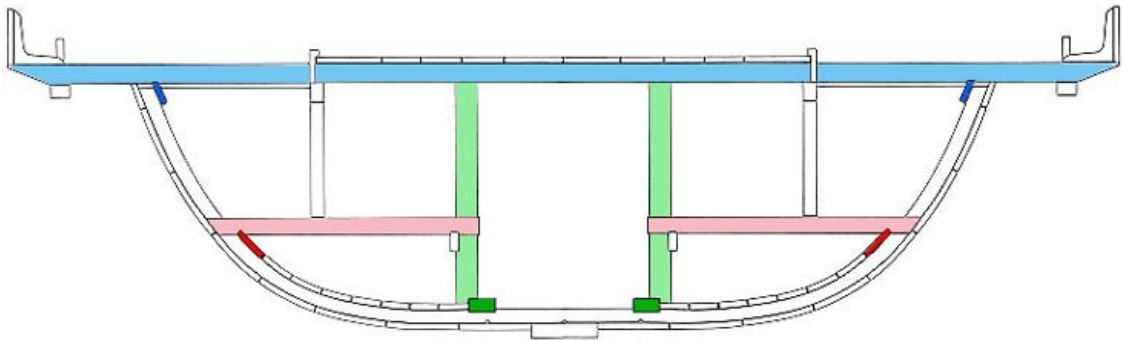

Mainz Nachbau 2

Obr.41 – priečny rez trupom lode číslo 3 z Mainzu

Available from: < <http://www2.rgzm.de/Navis/Home/NoFrames.htm>>. [27 July 2013].

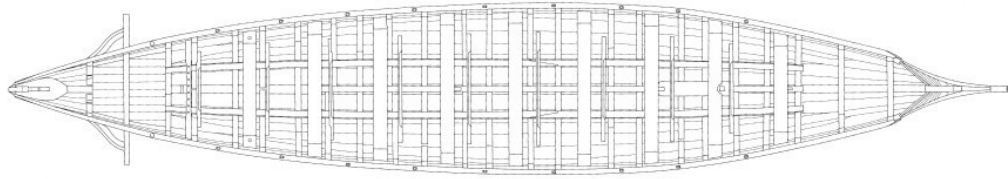

Obr.42 – plán trupu lode číslo 2 z Oberstimmu

Available from: < <http://www2.rgzm.de/Navis/Home/NoFrames.htm>>. [27 July 2013].

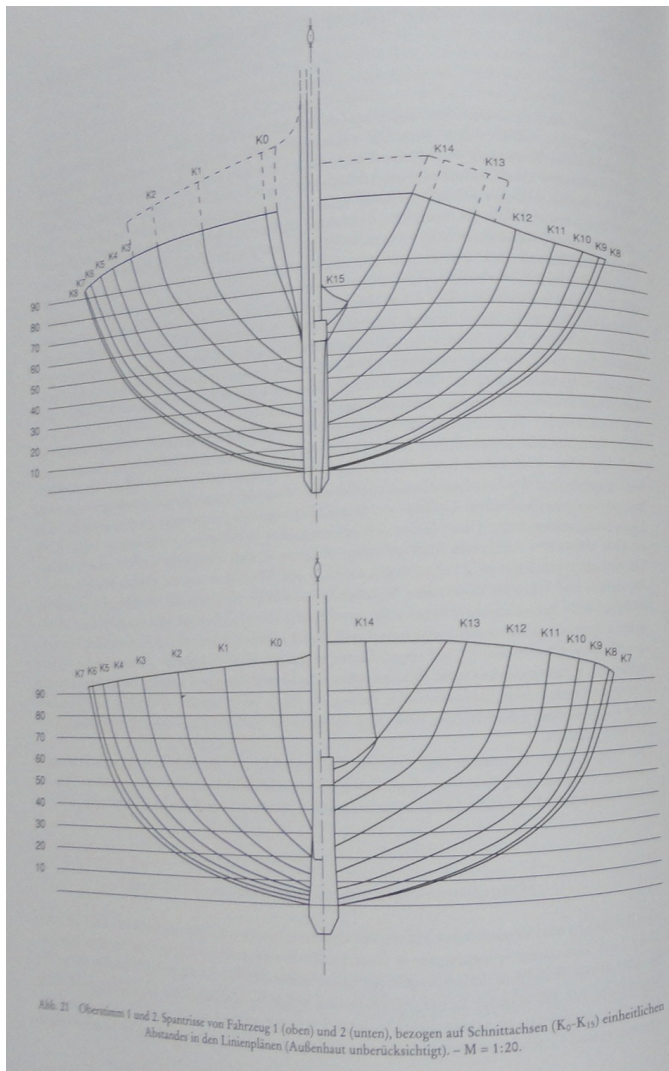

Obr.43 – priečný rez trupmi lodí číslo 1 a 2 z Oberstimmu

Available from: Bockius 2002, p.92

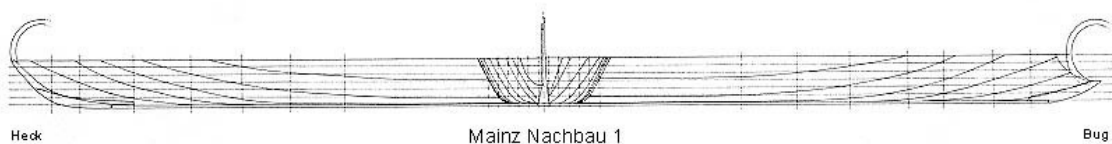

Obr.44 – plán a priečný rez trupu lode číslo Mainz A

Available from: < <http://www2.rgzm.de/Navis/Home/NoFrames.htm>>. [27 July 2013].



Obr.45 – reliéf číslo I. – III. z Traianovho stĺpa

Available from: Bartoli 1941, p.25



Obr.46 – reliéf číslo IV. z Traianovho stĺpa

Available from: Bartoli 1941, p.27



Obr.47 – reliéf číslo V. z Traianovho stĺpa

Available from: Bartoli 1941, p.29



Obr.48 – reliéfy číslo XXXIV. a XXXV. z Traianovho stĺpa

Available from: Bartoli 1941, p.67, 69



Obr.49 – reliéf číslo LXXIX. a LXXX. z Traianovho stĺpa

Available from: Bartoli 1941, p.137, 139



Obr.50 – baranidlo z Athlitu

Available from:

<<http://www.nmm.org.il/Museum/Templates/ShowPage.asp?DBID=1&LNGID=1&TMID=84&FID=1196&PID=2949>>. [27 July 2013].



Obr.51 – bronzové okovanie z Actia

Available from:

<http://www.britishmuseum.org/explore/highlights/highlight_image.aspx?image=ps344660.jpg&retpage=17970>. [27 July 2013].



Obr.52 – reliéf z Neapola

Available from: <<http://www2.rgzm.de/navis2/home/FramesE.cfm>>. [27 July 2013].



Obr.53 – reliéf číslo LXXXII. a LXXXIII. z Traianovho stípa

Available from: Bartoli 1941, p.141, 143



Obr.54 – replika athénskej triéry Olympias

Available from: <<http://www.telegraph.co.uk/sport/olympics/news/9213256/Olympic-warship-plan-sinks-over-safety-concerns-sparking-diplomatic-row.html>>. [27 July 2013].



Obr.55 – veslársky systém triéry Olympias

Available from:
<<http://www.militaryphotos.net/forums/album.php?albumid=1477&attachmentid=101881>>. [27 July 2013].



Obr.56 – freska z chrámu bohyně Isis v Pompejách

Available from: <<http://www2.rgzm.de/navis2/home/FramesE.cfm>>. [27 July 2013].