

9 Obrazová příloha

Soupis obrazových příloh:

- Tabulka 1 - Obr. 1 – Poloha vsi Třebovětice vzhledem k Hradci Králové
Obr. 2 – Poloha vsi Třebovětice vzhledem k Hořícím v Podkrkonoší
- Tabulka 2 - Obr. 1 – Umístění tvrze v intravilánu Třebovetic
Obr. 2 – Umístění tvrze na leteckém podkladu, kříž označuje místo, kde se nacházel sklep náležející k tvrzi
- Tabulka 3 - Obr. 1 – Prostor tvrziště zachycený na císařském otisku stabilního katastru, tmavomodře je zaneseno současné koryto potoka, protínající místa, kde stávala tvrz
Obr. 2. - Umístění tvrze na I. vojenském mapování
- Tabulka 4 - Obr. 1 – Ekogram osídlení. Jako mapový podklad posloužilo I. vojenské mapování (čísla v závorkách udávají první písemnou zmínku)
- Tabulka 5 - Obr. 1 - Ekogram znázorňující základní přírodní podmínky
- Tabulka 6 - Obr. 1 – Plán znázorňující rozsah vykopaného zdiva (podle E. Dufka – upraveno)
- Tabulka 7 - Obr. 1 - Řez -AB- (podle E. Dufka – upraveno)
Obr. 2 - Řez -CD- (podle E. Dufka – upraveno)
Obr. 3 - Řez -EF- (podle E. Dufka – upraveno)
Obr. 4 - Řez -NO- (podle E. Dufka – upraveno)
- Tabulka 8 - Obr. 1 - Řez -GH- (podle E. Dufka – upraveno)
Obr. 2 - Řez -JK- (podle E. Dufka – upraveno)
Obr. 3 - Řez -LM- (podle E. Dufka – upraveno)
Obr. 4 - Řez -PR- (podle E. Dufka – upraveno)
- Tabulka 9 - Obr. 1 - Řez -ST- (podle E. Dufka – upraveno)
Obr. 2 – Šipky znázorňující směry pořízení fotografií
- Tabulka 10 - Obr. 1 – Rekonstrukce rozsahu obnaženého zdiva, pohled od jihovýchodu
- Tabulka 11 - Obr. 1 – Rekonstrukce rozsahu obnaženého zdiva, pohled od severovýchodu
- Tabulka 12 - Obr. 1 – Rekonstrukce rozsahu obnaženého zdiva, pohled od jihu
- Tabulka 13 - Obr. 1 – Schéma možného stavebního vývoje tvrze
- Tabulka 14 - Obr. 1 – fotografie č. 1
Obr. 2 – fotografie č. 2
- Tabulka 15 - Obr. 1 – fotografie č. 3

Obr. 2 – fotografie č. 4
Tabulka 16 - Obr. 1 – fotografie č. 5
Obr. 2 – fotografie č. 6
Tabulka 17 - Obr. 1 – fotografie č. 7
Obr. 2 – fotografie č. 8
Tabulka 18 - Obr. 1 – fotografie č. 9
Obr. 2 – fotografie č. 10
Tabulka 19 - Obr. 1 – fotografie č. 11
Obr. 2 – fotografie č. 12
Tabulka 20 - Obr. 1 – fotografie č. 13
Obr. 2 – fotografie č. 14
Tabulka 21 - Obr. 1 – fotografie č. 15
Obr. 2 – fotografie č. 16
Tabulka 22 - Obr. 1 – fotografie č. 17
Tabulka 23 - Obr. 1-2 – keramické nálezy
Tabulka 24 - Obr. 1-2 – keramické nálezy
Tabulka 25 - Obr. 1-2 – keramické nálezy
Tabulka 26 - Obr. 1-2 – keramické nálezy
Tabulka 27 - Obr. 1-2 – keramické nálezy
Tabulka 28 - Obr. 1-3 – keramické nálezy
Tabulka 29 - Obr. 1-2 – keramické nálezy
Tabulka 30 - Obr. 1-3 – keramické nálezy
Tabulka 31 - Obr. 1-2 – keramické nálezy
Tabulka 32 - Obr. 1-3 – keramické nálezy
Tabulka 33 - Obr. 1-4 – keramické nálezy
Tabulka 34 - Obr. 1-4 – keramické nálezy
Tabulka 35 - Obr. 1-3 – keramické nálezy
Tabulka 36 - Obr. 1-8 – keramické nálezy
Tabulka 37 - Obr. 1-10 – keramické nálezy
Tabulka 38 - Obr. 1-8 – keramické nálezy
Tabulka 39 - Obr. 1-4 – keramické nálezy
Tabulka 40 - Obr. 1-6 – keramické nálezy
Tabulka 41 - Obr. 1-4 – keramické nálezy
Tabulka 42 - Obr. 1 – Kachel
Tabulka 43 - Obr. 1 – Kachel

Tabulka 44 - Obr. 1 – Kachel
Tabulka 45 - Obr. 1-2 – kachle
Tabulka 46 - Obr. 1-4 – kachle
Tabulka 47 - Obr. 1-4 – kachle
Tabulka 48 - Obr. 1-5 – kachle
Tabulka 49 - Obr. 1-4 – kachle
Tabulka 50 – Obr. 1 – kachel
Tabulka 51 - Obr. 1-3 – kachle
Tabulka 52 - Obr. 1 – kachel
Tabulka 53 - Obr. 1 – kachel
Tabulka 54 - Obr. 1 – kachel
Tabulka 55 - Obr. 1-3 – skleněné nálezy
Tabulka 56 - Obr. 1-6 – skleněné nálezy
Tabulka 57 - Obr. 1-11 – skleněné nálezy
Tabulka 58 - Obr. 1-6 – skleněné nálezy
Tabulka 59 - Obr. 1-10 – skleněné nálezy
Tabulka 60 - Obr. 1-14 – skleněné nálezy
Tabulka 61 - Obr. 1 – kování rýče
Tabulka 62 - Obr. 1 – sekera
Tabulka 63 - Obr. 1-2 – kovové nálezy
Tabulka 64 - Obr. 1-3 – kovové nálezy
Tabulka 65 - Obr. 1-2 – kovové nálezy
Tabulka 66 - Obr. 1-4 – kovové nálezy
Tabulka 67 - Obr. 1 - Hák
Tabulka 68 - Obr. 1-4 – kovové nálezy
Tabulka 69 - Obr. 1-4 – kovové nálezy
Tabulka 70 - Obr. 1-4 – kovové nálezy
Tabulka 71 - Obr. 1 – nálezy usňových dílců
Tabulka 72 - Obr. 1-2 – kostěné nálezy
Tabulka 73 - Obr. 1 – pilota
Obr. 2 – kamenný architektonický článek (nedochováno)
Tabulka 74 - Obr. 1 – Portál (nedochováno)
Obr. 2 – Džbán (kat. č. 1) – příklad redukčně pálené keramiky
Obr. 3 – Džbán (kat. č. 3) – příklad redukčně pálené keramiky
Tabulka 75 - Obr. 1 – Hrnc (kat. č. 5)

Obr. 2 – Hrnc (kat. č. 6)

Obr. 3 – Hrnc dvojuchý (kat. č. 7)

Obr. 4 – Pohár (kat. č. 10)

Tabulka 76 - Obr. 1 – příklad podsypané dna, s viditelným napojením dna a těla nádoby
(kat. č. 5)

Obr. 2 – příklad dna se zřetelnými stopami po odříznutí (kat. č. 4)

Obr. 3 – část těla džbánu (kat. č. 65)

Obr. 4 – talíř (kat. č. 19)

Obr. 5 – zlomek talíře (kat. č. 21)

Obr. 6 – zlomky talíře (kat. č. 22)

Tabulka 77 - Obr. 1 – spodní část číše (kat. č. 119)

Obr. 2 – okraj číše (kat. č. 118)

Obr. 3 – zlomek číše? (kat. č. 122)

Obr. 4 – zlomek číše (kat. č. 120)

Obr. 5 – zlomky číše? (kat. č. 123)

Obr. 6 – zlomky lahve (kat. č. 149)

Tabulka 78 - Obr. 1 – zlomky džbánu? (kat. č. 140)

Obr. 2 – vrchní část konvice (kat. č. 139)

Obr. 3 – pákové udílo (kat. č. 190)

Obr. 4 – detail výzdoby rukojeti nože s dochovaným dřevem (kat. č. 192)

Obr. 5 – detail výzdoby rukojeti nože s dochovanou parohovinou (kat. č. 191)

Tabulka 79 - Obr. 1 – zastoupení hlavních tvarů skleněných nálezů

Obr. 2 – motiv Vyhnání z Bible krále Václava IV. (podle Hazlbauer 1991, 177)

Obr. 3 – motiv Vyhnání z Queen Mary's Psalter (podle Urbánková Stejskal 1975, 100)

Obr. 4 – mince ražená komturem Pavlem von Russdorf (1422-1441), Gdaňsk
(podle Kopicki 1975, 167)

Obr. 5 – mince ražená komturem Konrádem von Erlichhausen (1441-1449),
Gdaňsk, (podle Kopicki 1975, 167)

Tabulka 80 - Obr. 1 – skupina halapartníků první dvaceti let 16. století (podle Klučina 2004, 534)

Obr. 2 – halapartna doby Maxmiliána I. okolo roku 1500 (Boeheim 1890, 332).

Obr. 3 – halapartna, konec 15. století (podle (Boeheim 1890, 40)

Obr. 4 – příklad bojového kladiva (podle Klučina 2004, 43)

Obr. 5 – Pěší halapartník na zobrazení okolo r. 1505 (podle Klučina 2004, 539)

Obr. 6 – Pákové udílo z konce 15. století (podle Boeheim 1890, 194)

Obr. 7 – nárameník pozdně gotické zbroje z doby kolem roku 1480, Německo
(podle Hrbatý 2006, 63)

Obr. 8 – kresba pozdně gotické zbroje podle originálu z roku 1480, Německo
(podle Hrbatý 2006, 59)

Tabulka 81 - Obr. 1 – detail obrazu Quentina Massyse z roku 1514 – na stole jsou vidět lotová
závaží (podle Krajíc 2006, 310)

Obr. 2 – Noe při práci na vinici používá rýč s kovovou násadou – Velislavova
Bible (podle Matějček 1926, fol.10)

Obr. 3 – kompletní rozložená sada lotových závaží

Obr. 4 – Hák, Soubor lidových staveb Vysočina, skanzen Veselý kopec

Obr. 5 – rýč s kovovou násadou, Soubor lidových staveb východní Hané Rymice u
Holešova

Poznámka:

Číslo uváděné v závorce za číslem obrázku odkazuje na katalogové číslo nálezu

Grafické značky rozlišují u vybraných nádob technologické stopy na podstavě nádoby:

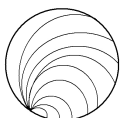

Dno odříznuté

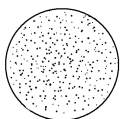

Podsýpka, dno rovné



1

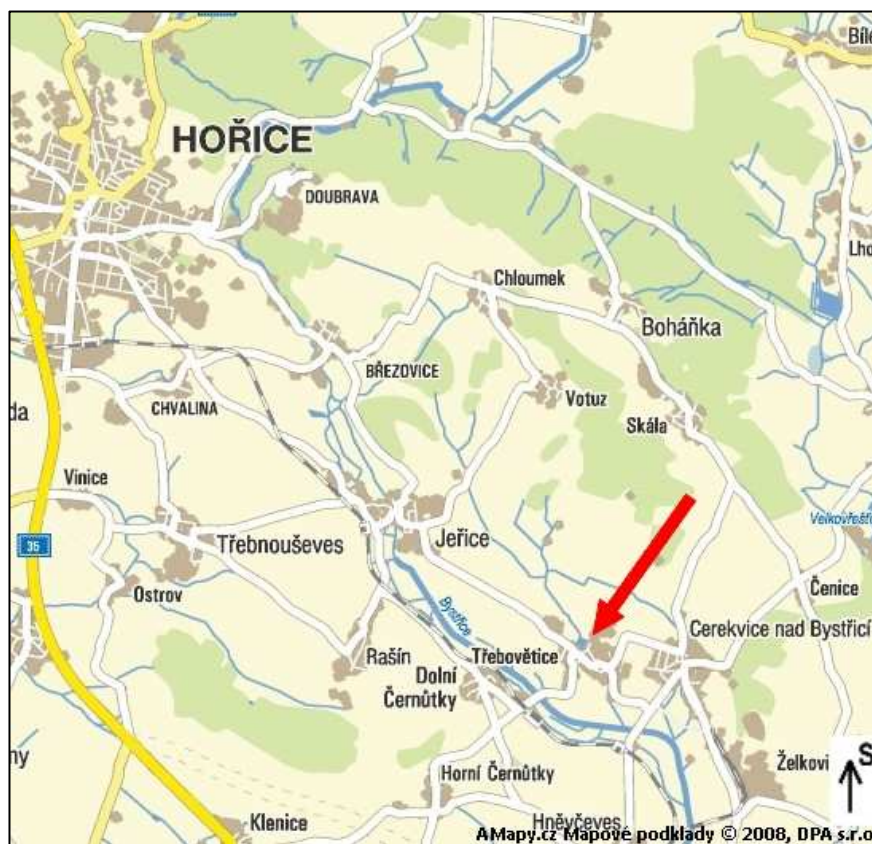

2

- 1 – Poloha vsi Třebovčice vzhledem k Hradci Králové
- 2 – Poloha vsi Třebovčice vzhledem k Hořicím v Podkrkonoší

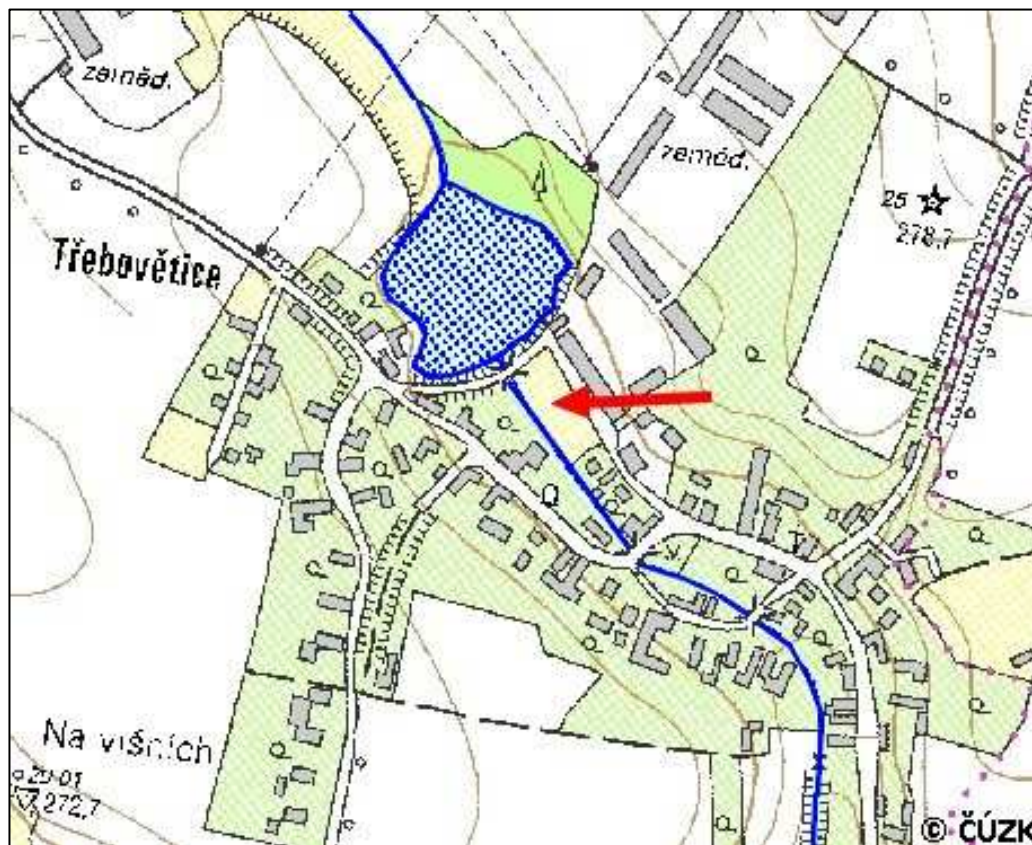

1



2

- 1 – Umístění tvrze v intravilánu Třebovětice
 2 – Umístění tvrze na leteckém podkladu, kříž označuje místo, kde se nacházel sklep náležející k tvrzi

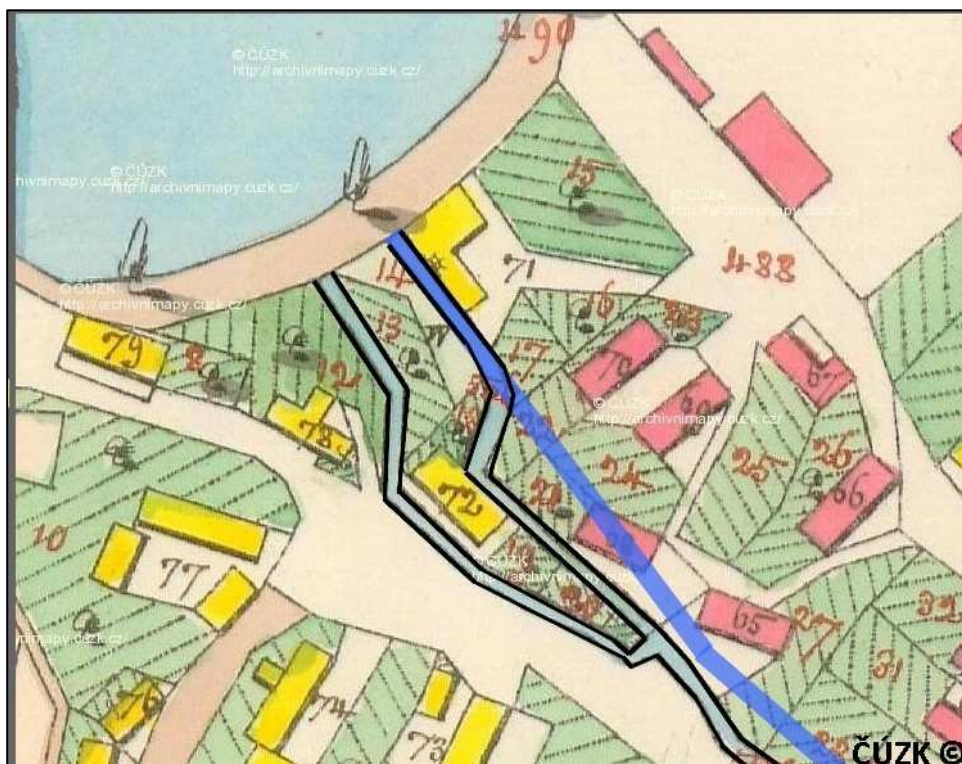

1

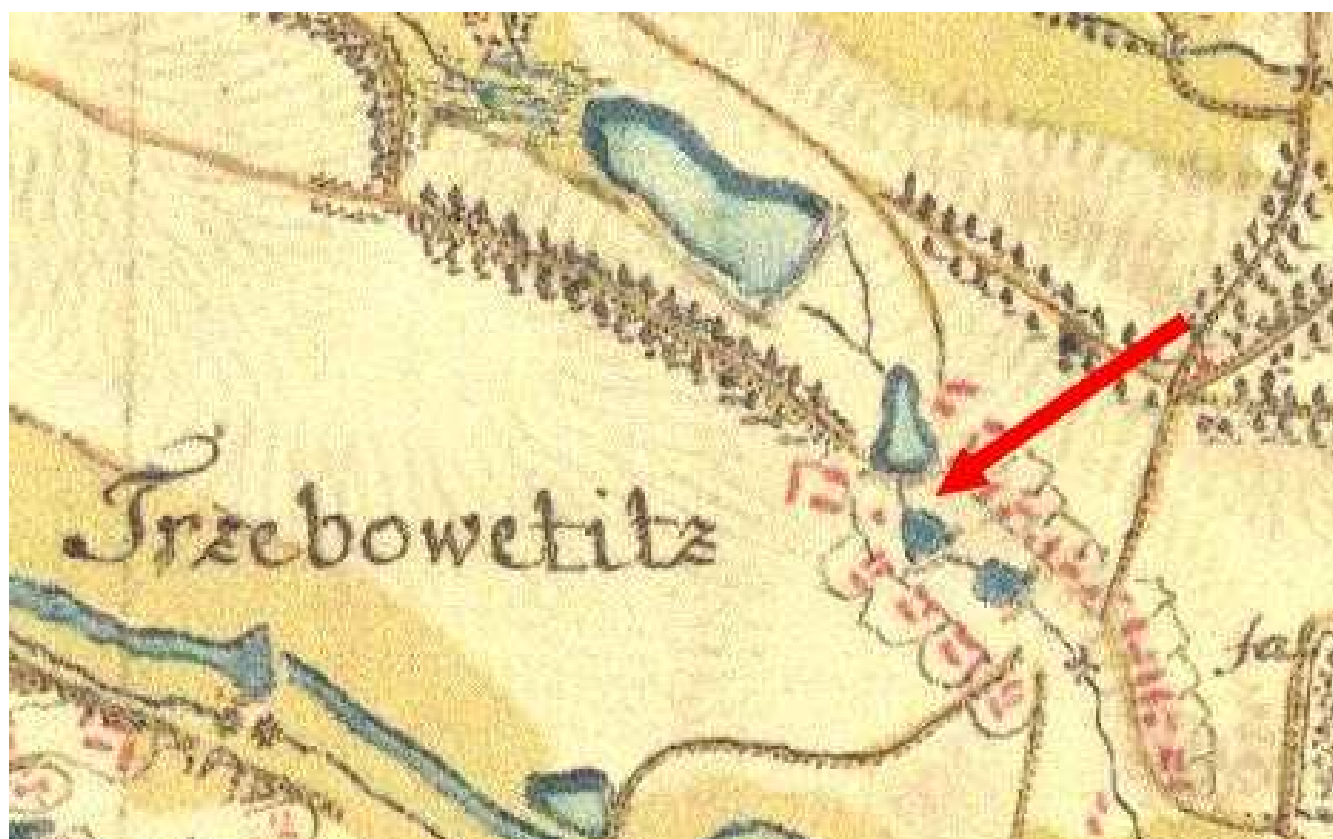

2

1 – Prostor tvrziště zachycený na císařském otisku stabilního katastru, tmavomodře je zaneseno současné koryto potoka, protínající místa, kde stávala tvrz

2. – Umístění tvrze na I. vojenském mapování

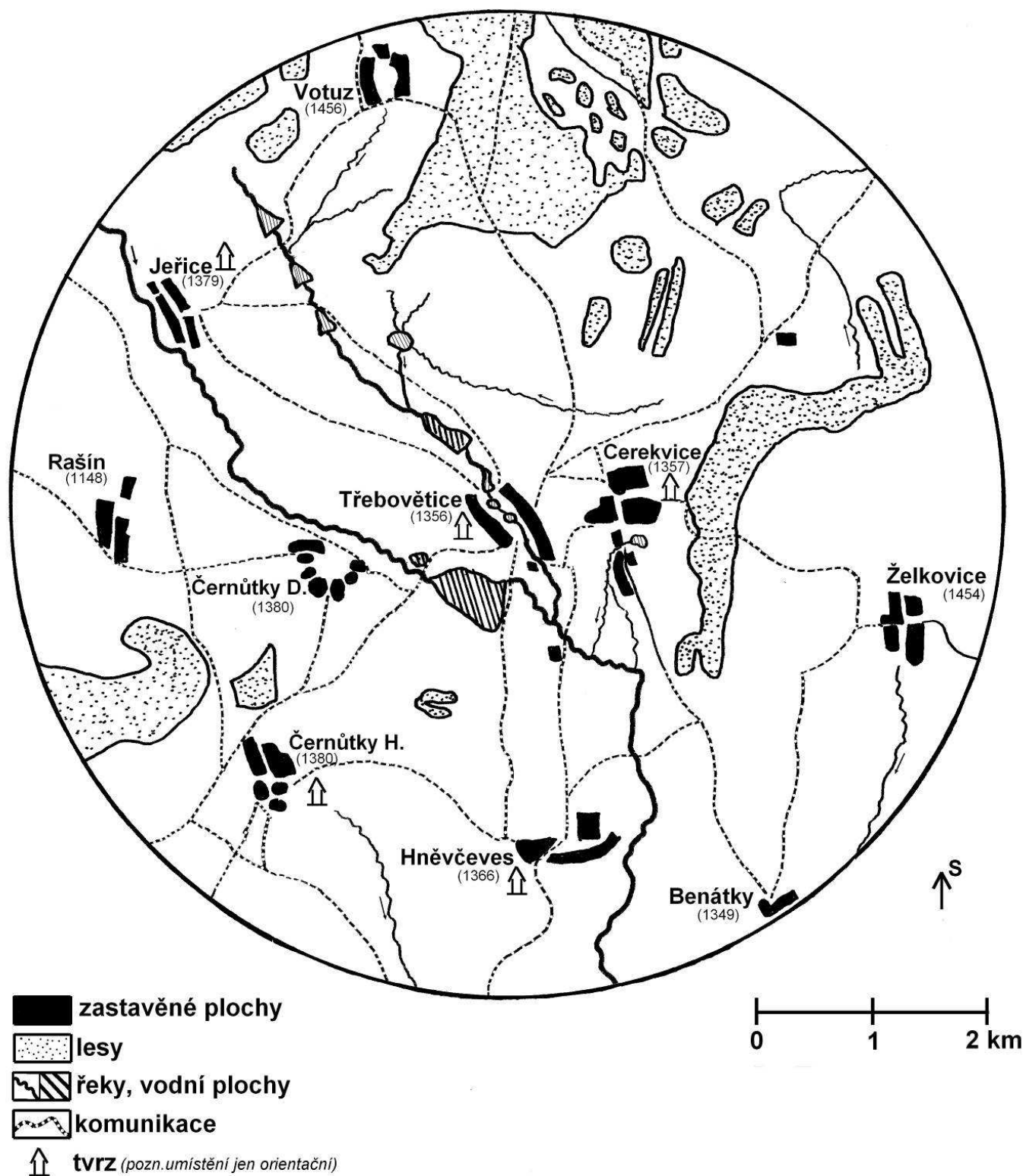

poznámka: jako mapový zdroj bylo použito I. Vojenské mapování
 © Laborator geoinformatiky Univerzity J. E. Purkyně
 © Ministerstvo životního prostředí České republiky
 © Austrian State Archive/Military Archive, Vienna

1

1 – Ekogram osídlení. Jako mapový podklad posloužilo I. vojenské mapování (čísla v závorkách udávají první písemnou zmínku)

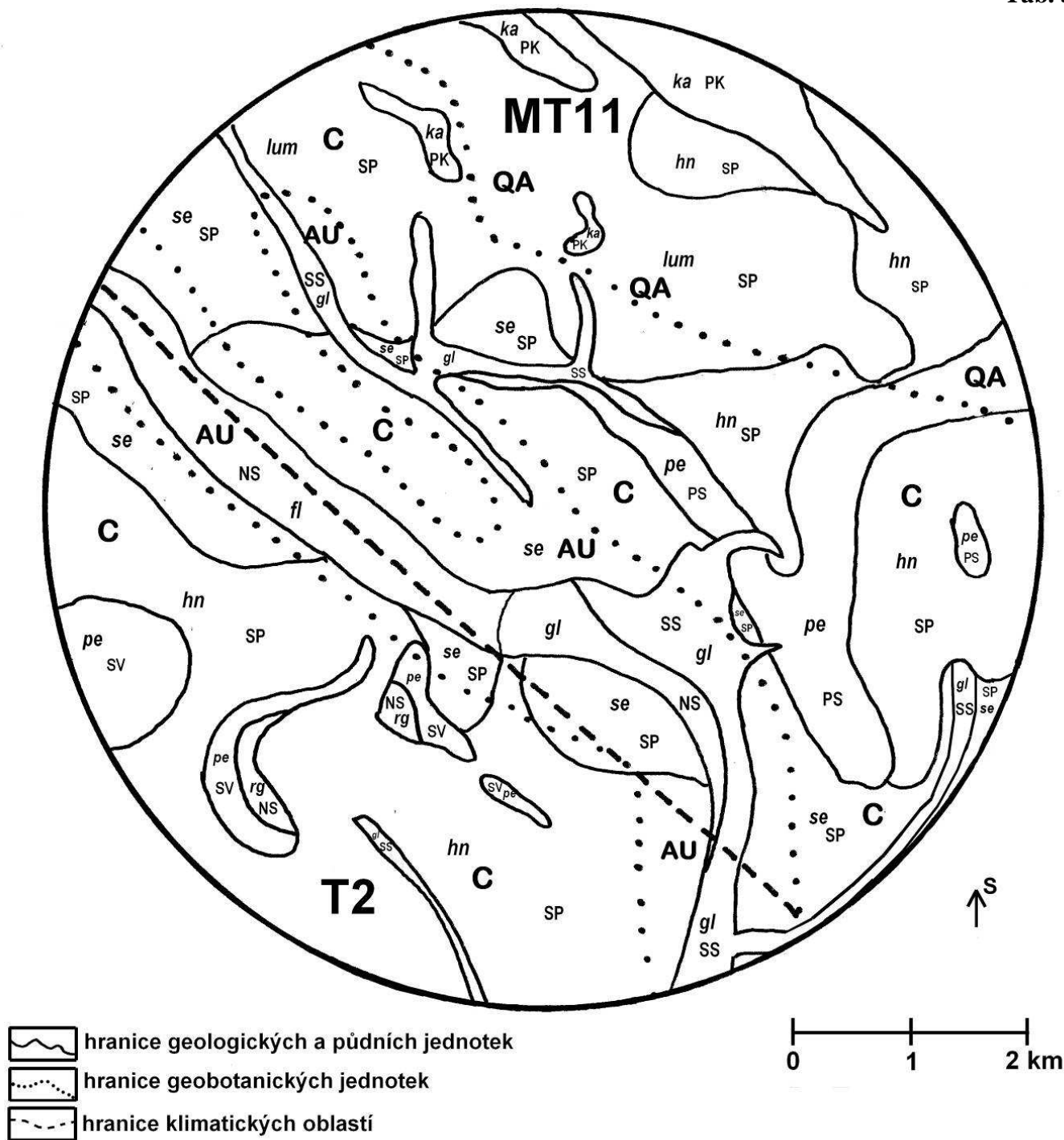
Český masiv – pokryvné útvary

kenozoikum

kvartér *holocén*: NS – nivní sediment; SS – smíšený sediment*pleistocén*: SP – spraš a sprašová hlína (eolická)

mezozoikum

křída svrchní

SV – slínovce s polohami či konkréciemi vápenců; PS – písčité slínovce až jílovce spongilitické;

PK – pískovce křemenné, jílovité, glaukonitické

Půdní jednotky: lum – luvizemě; hn – hnědozemě; se – šedozemě; fl – fluvizemě; rg – regozemě; gl – glej;

ka – kambizemě; pe – pelozemě

Geobotanické jednotky: AU – luhy a olšiny; QA – acidofilní doubravy; C – dubohabrové háje

Klimatické oblasti: T2 – Ø teplota v lednu-2 - -3°C; Ø teplota v červenci 18 - 19°C; srážkový úhrn ve veg. období 350-400 mm; srážkový úhrn v zim. období 200-300 mm

MT11 – Ø teplota v lednu-2 - -3°C; Ø teplota v červenci 17 - 18°C; srážkový úhrn ve veg. období 350-400 mm; srážkový úhrn v zim. období 200-250 mm

1

1 Ekogram znázorňující základní přírodní podmínky

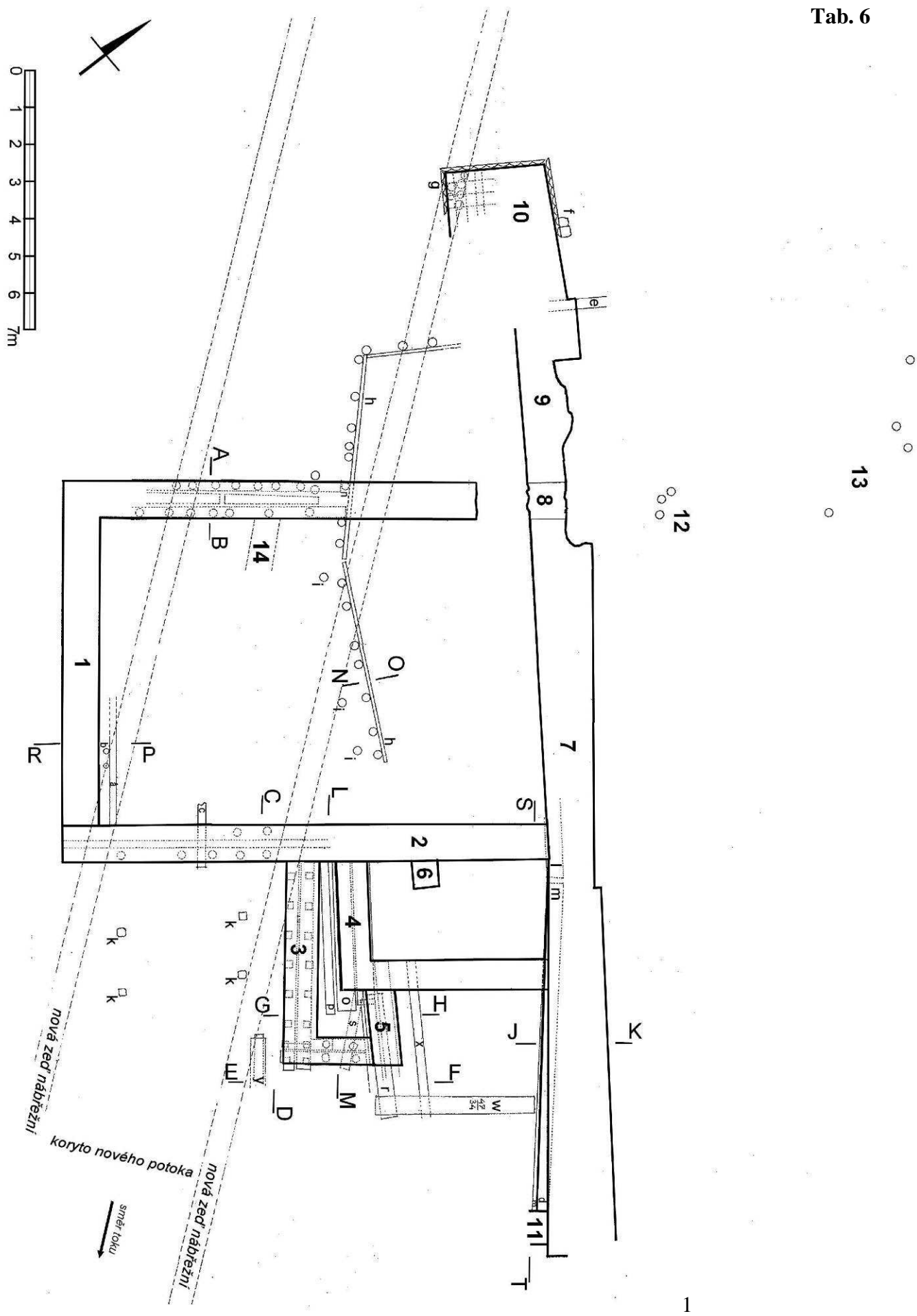

1 – Plán znázorňující rozsah vykopaného zdiva (podle E. Dufka – upraveno)

řez -AB-

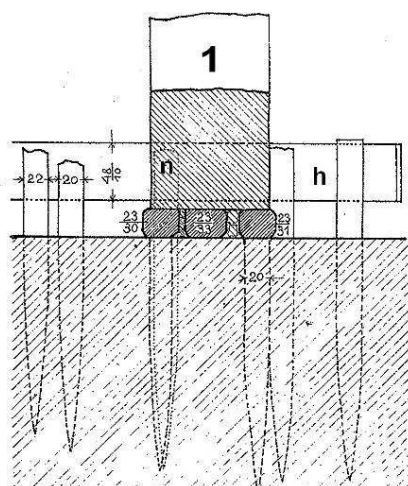

1

řez -CD-

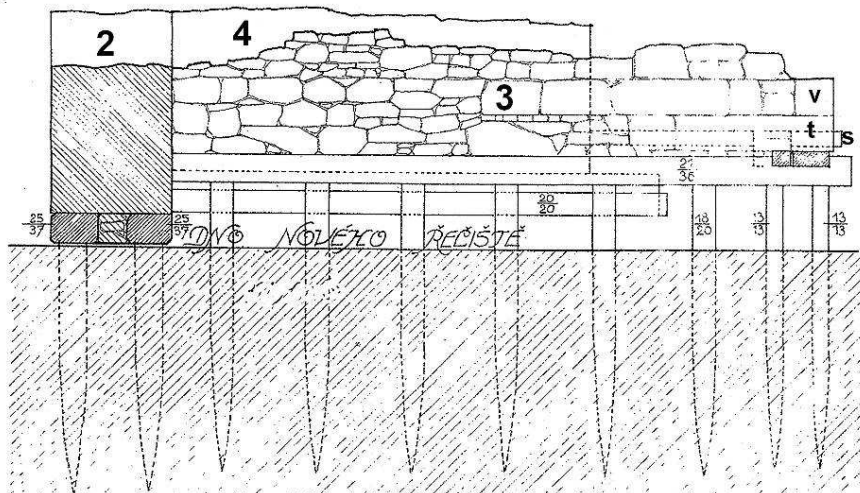

2

řez -EF-

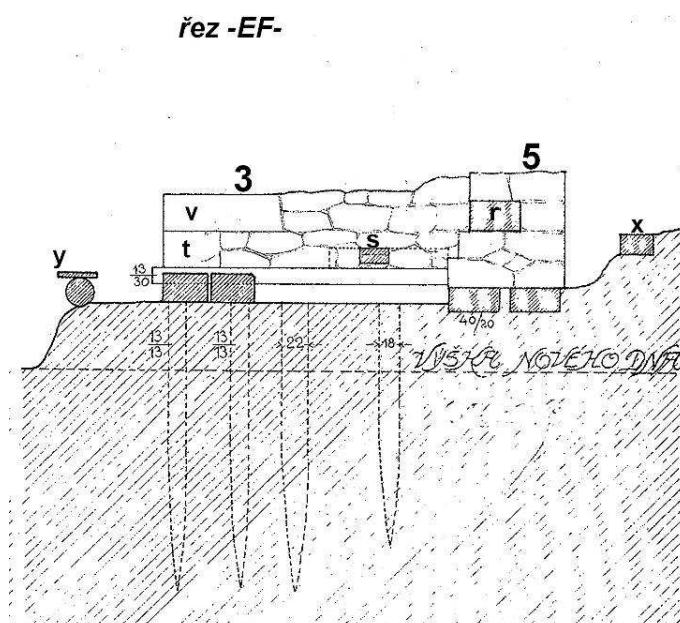

3

řez -NO-

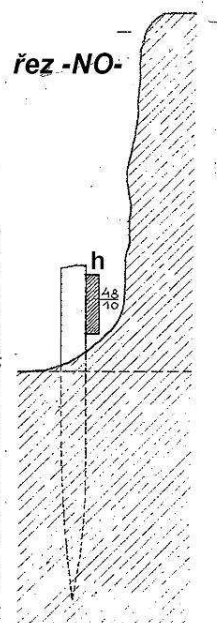

4



- 1 - Řez -AB- (podle E. Dufka – upraveno)
- 2 - Řez -CD- (podle E. Dufka – upraveno)
- 3 - Řez -EF- (podle E. Dufka – upraveno)
- 4 - Řez -NO- (podle E. Dufka – upraveno)

řez -GH-

řez -JK-

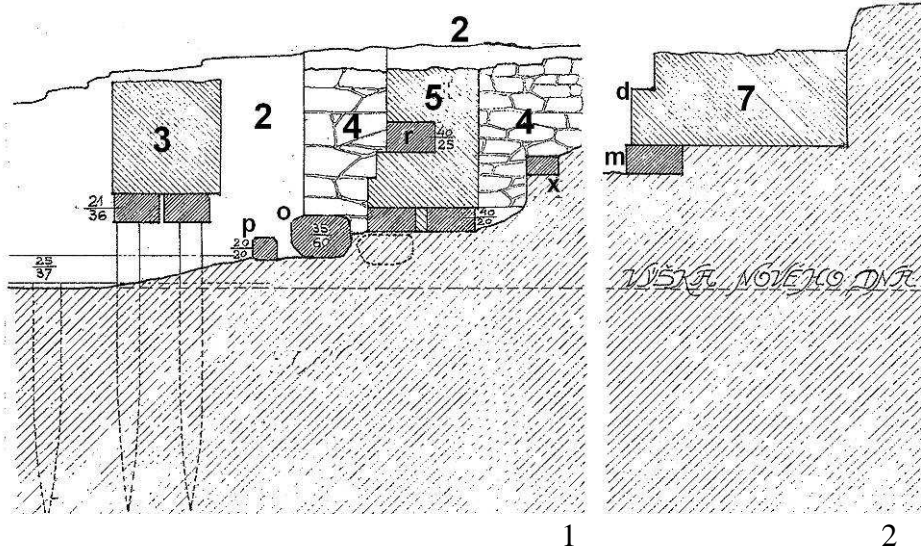

řez -LM-

řez -PR-

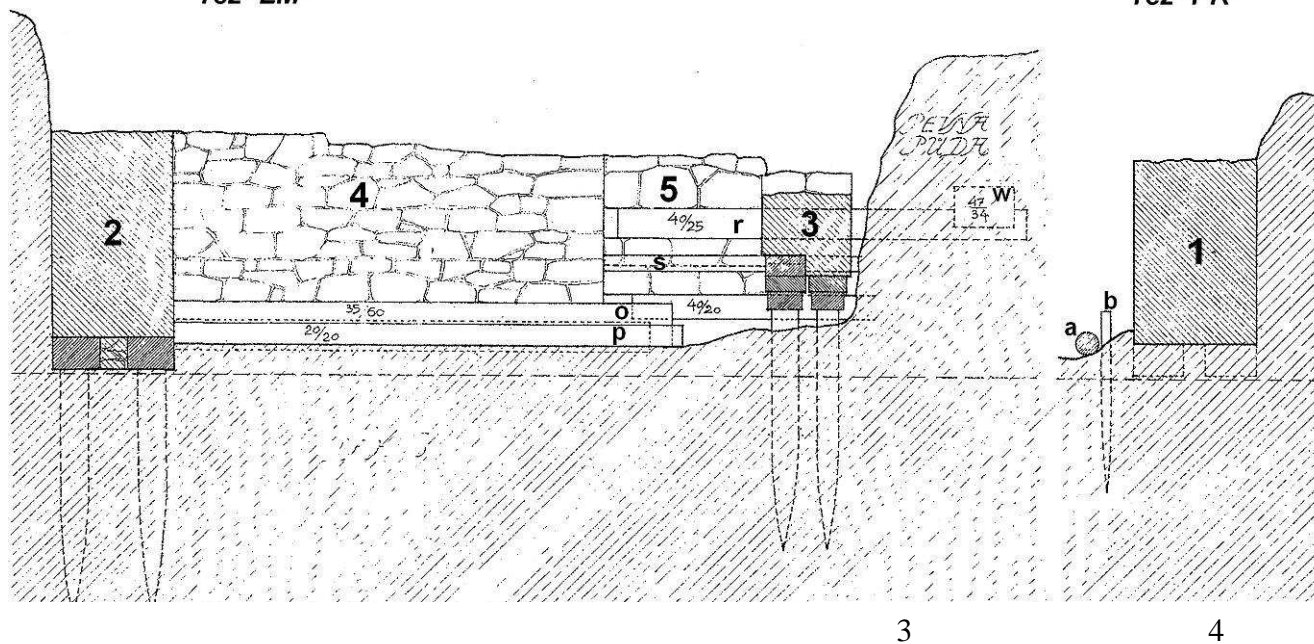

- 1 - Řez -GH- (podle E. Dufka – upraveno)
- 2 - Řez -JK- (podle E. Dufka – upraveno)
- 3 - Řez -LM- (podle E. Dufka – upraveno)
- 4 - Řez -PR- (podle E. Dufka – upraveno)

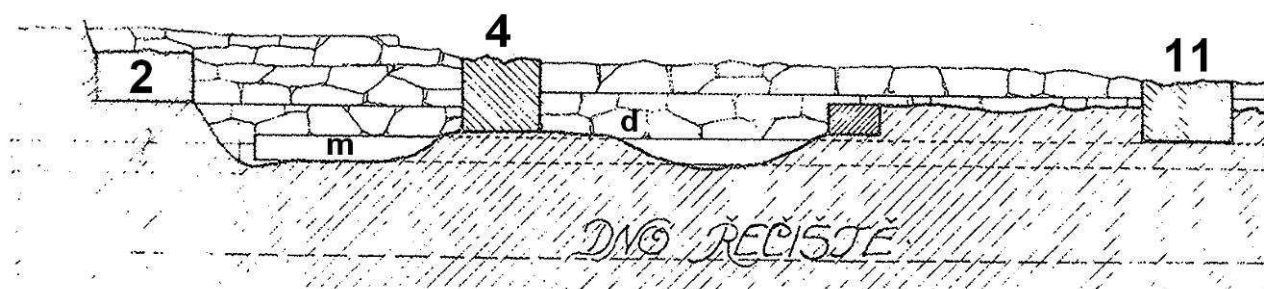

1

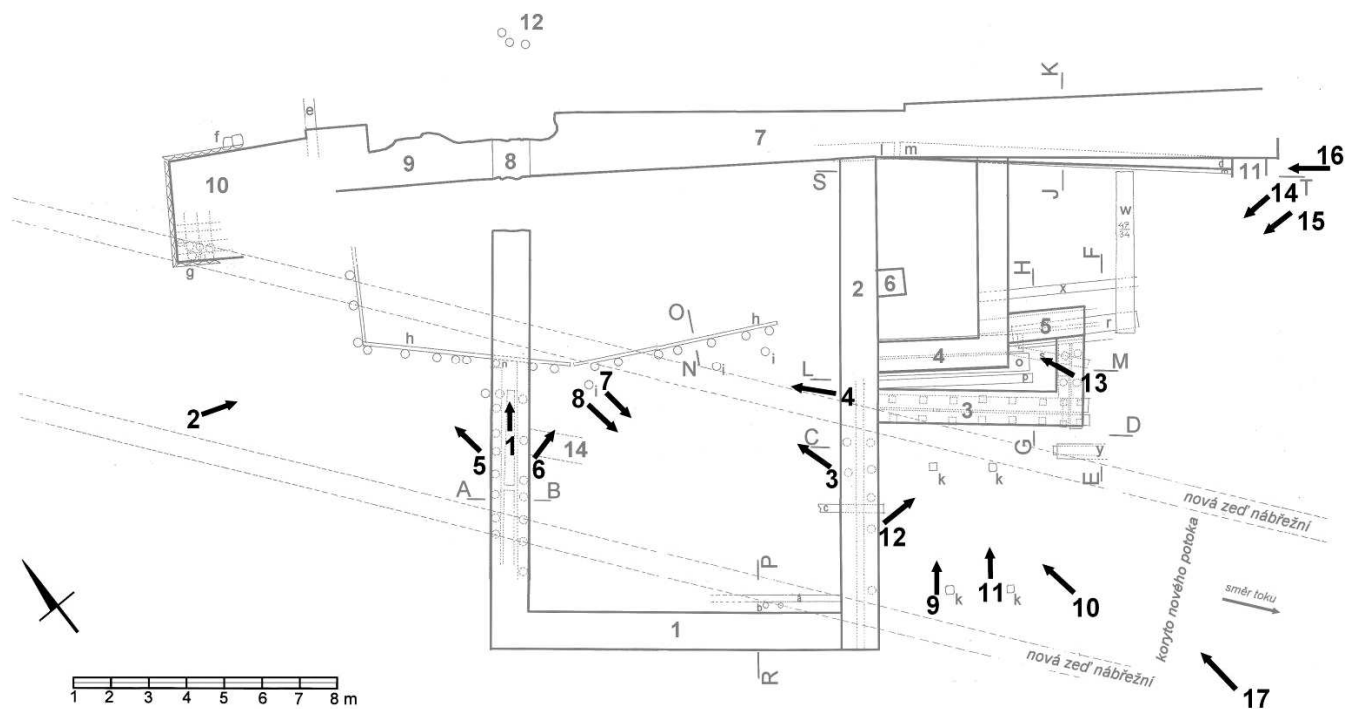

2

- 1 - Řez -ST- (podle E. Dufka – upraveno)
 2 - Šipky znázorňující směry pořízení fotografií

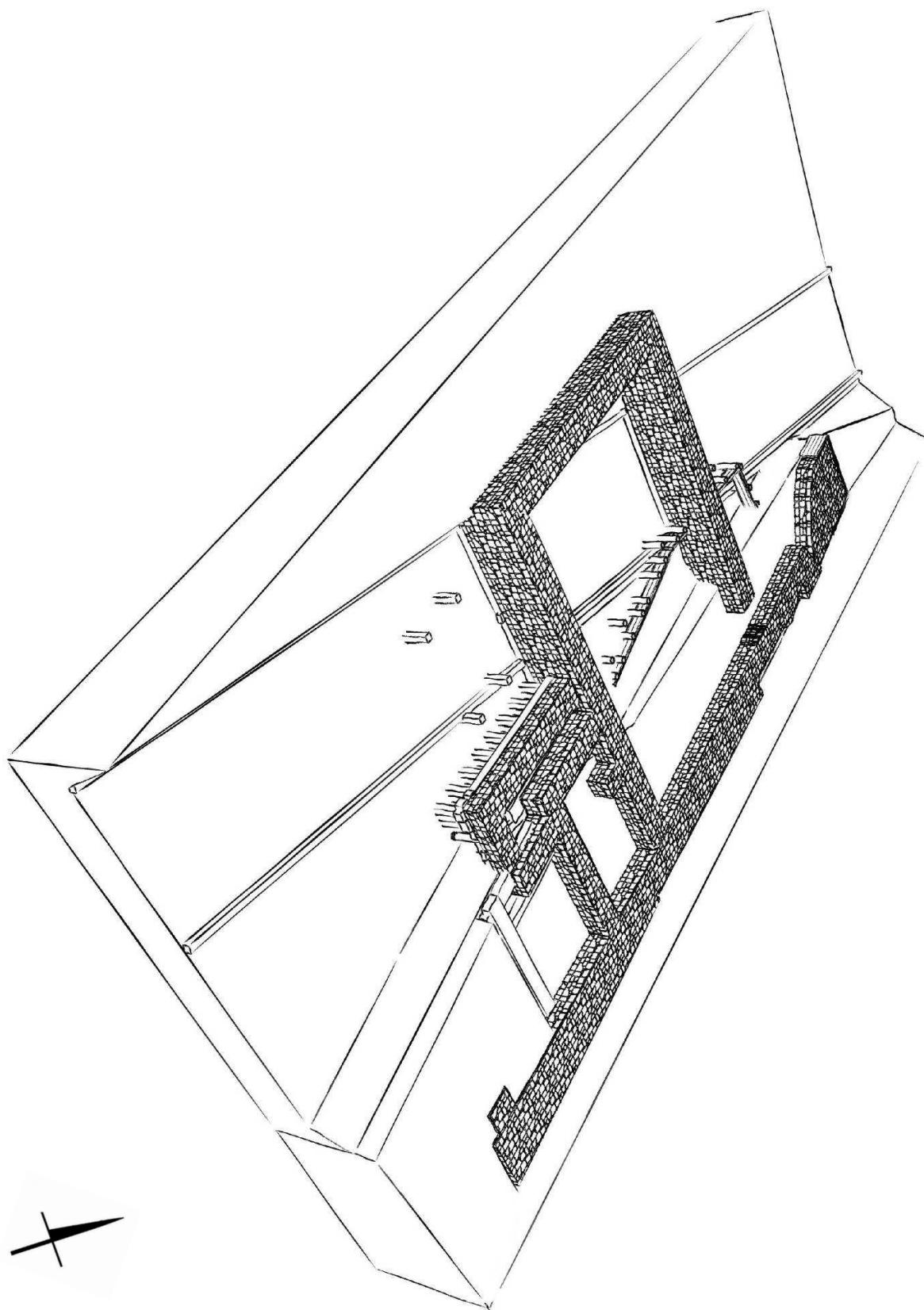

1

1 – Rekonstrukce rozsahu obnaženého zdiva, pohled od jihovýchodu

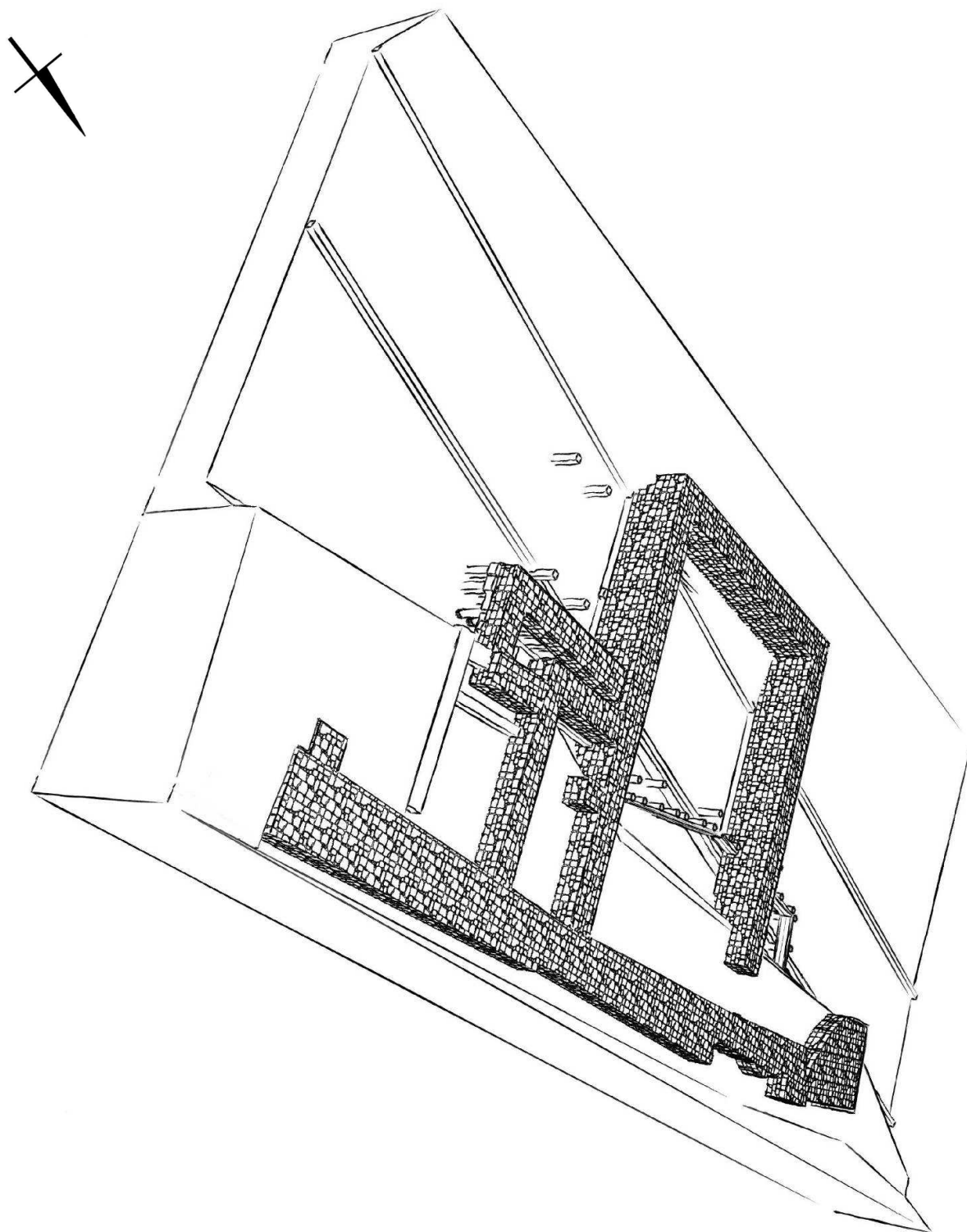

1

1 – Rekonstrukce rozsahu obnaženého zdiva, pohled od severovýchodu

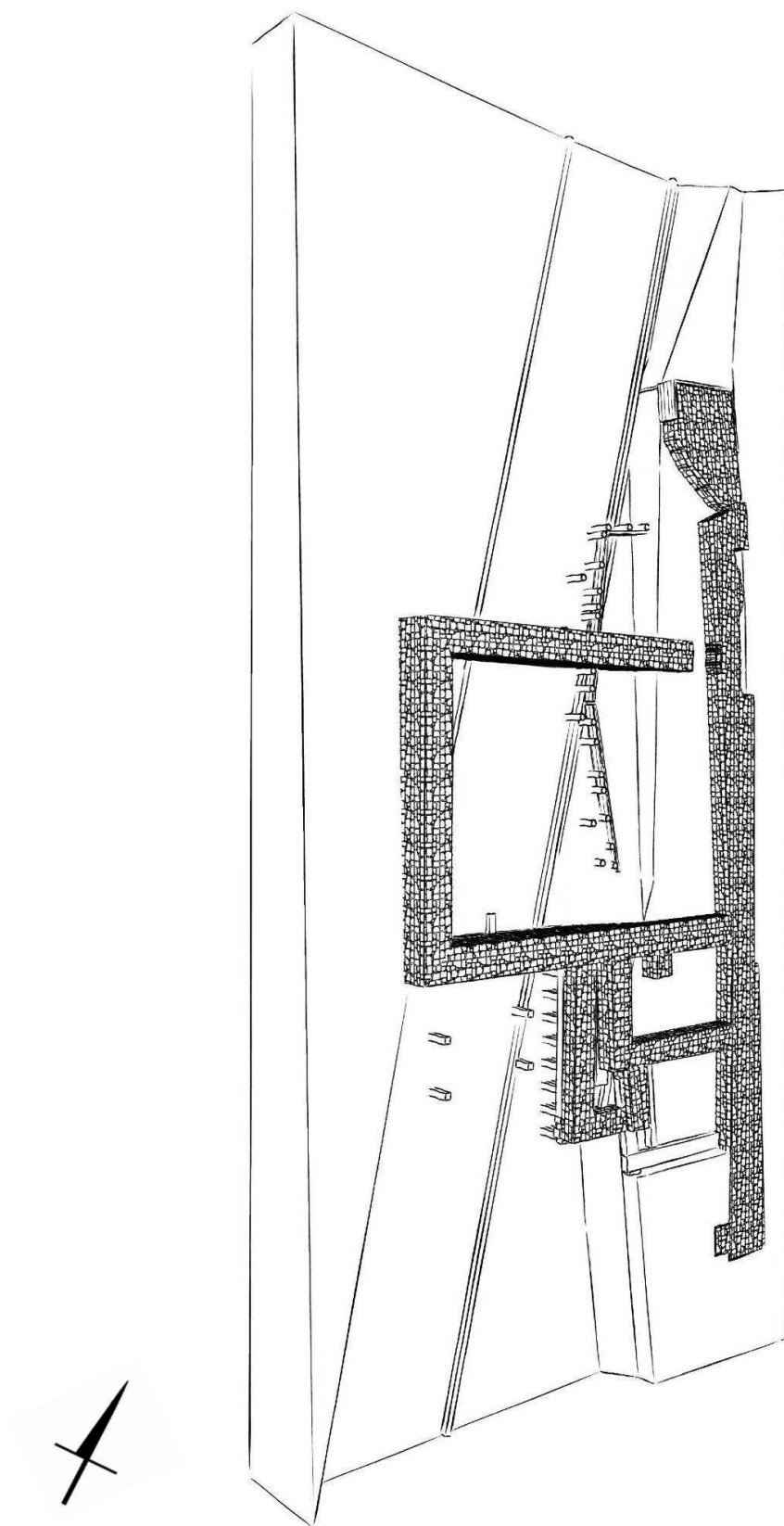

1 – Rekonstrukce rozsahu obnaženého zdiva, pohled od jihu

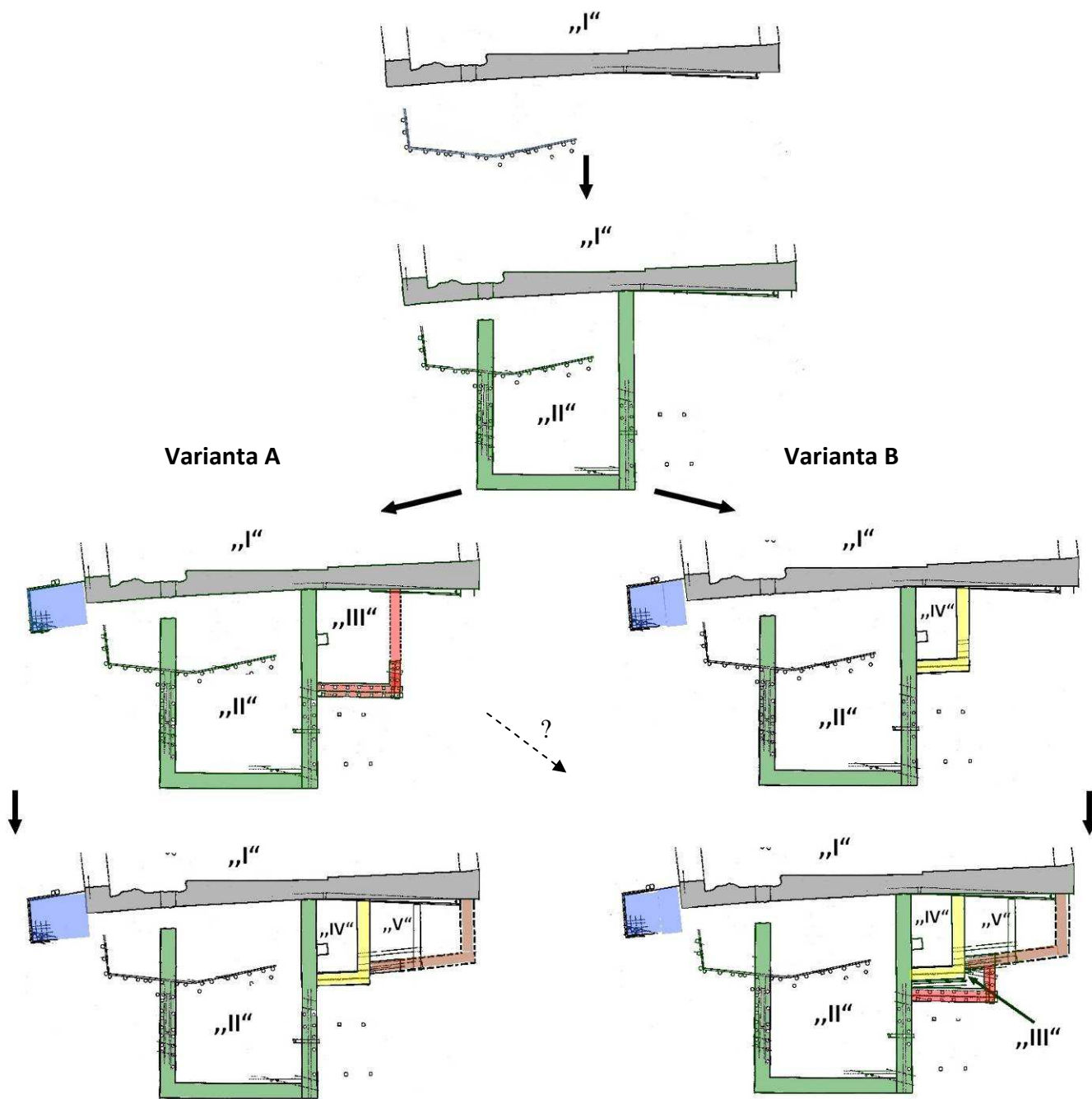

1

1 – Schéma možného stavebného vývoje tvrže



1

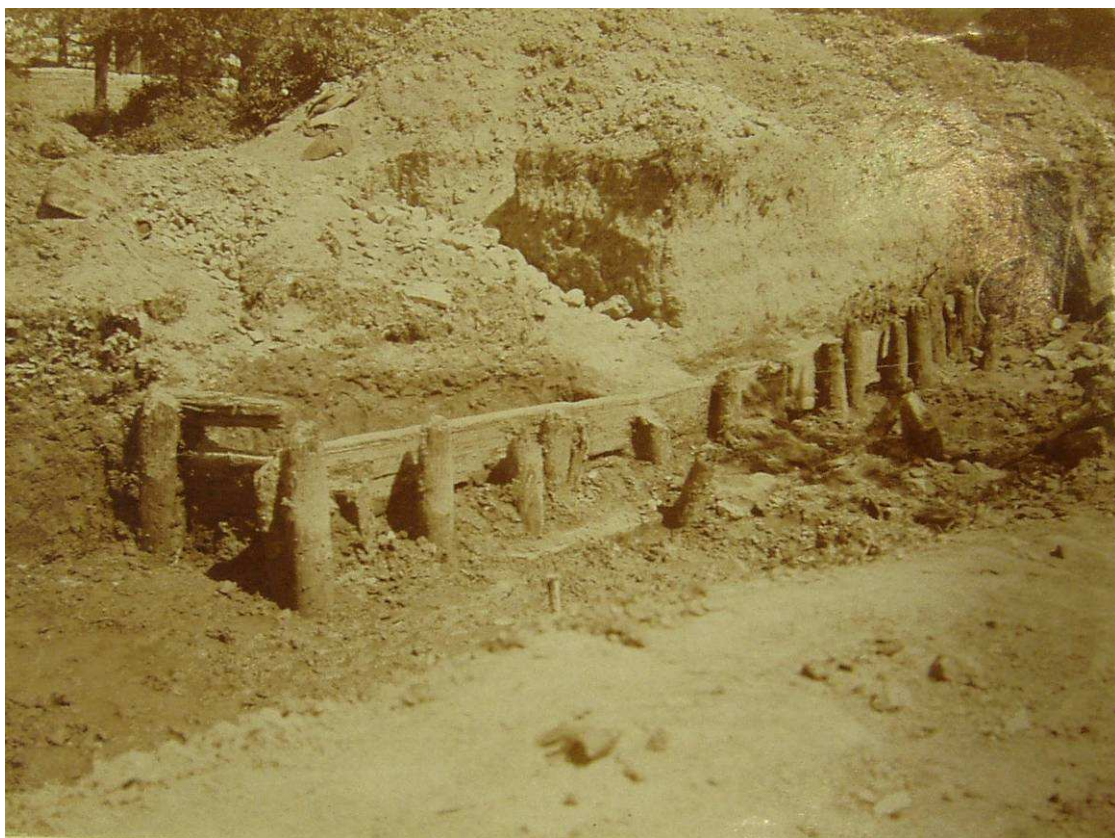

2

1 – fotografie č. 1
2 – fotografie č. 2



1



2

1 – fotografie č. 3
2 – fotografie č. 4



1



2

1 – fotografie č. 5
2 – fotografie č. 6



1

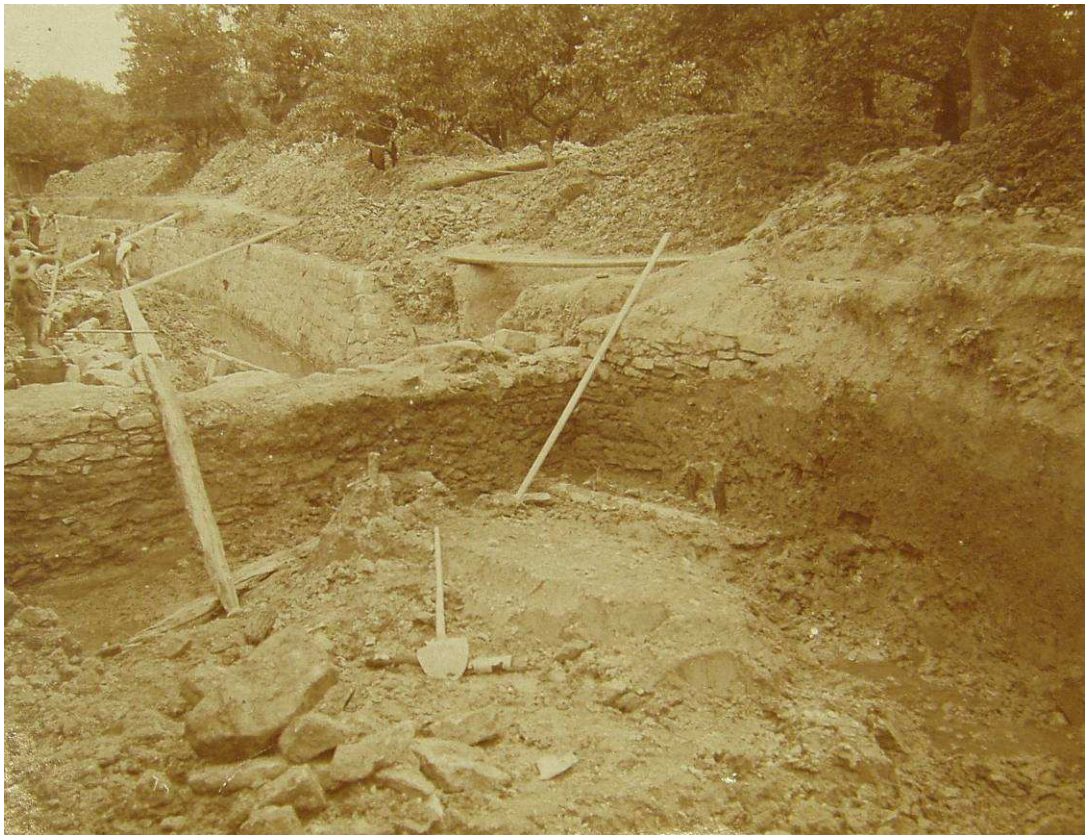

2

1 – fotografie č. 7
2 – fotografie č. 8



1



2

1 – fotografie č. 9
2 – fotografie č. 10



1



2

1 – fotografie č. 11
2 – fotografie č. 12



1



2

1 – fotografie č. 13
2 – fotografie č. 14



1

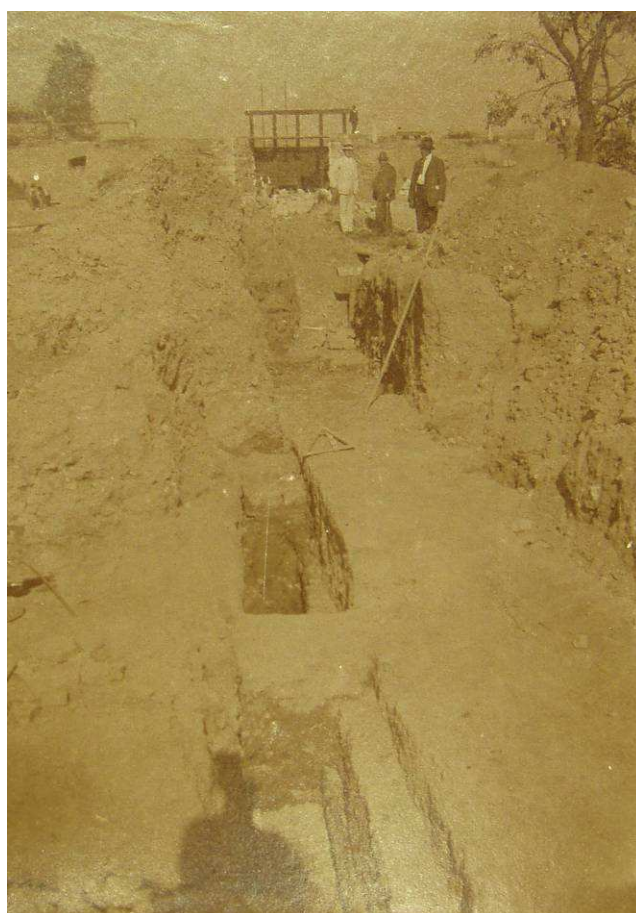

2

1 – fotografie č. 15
2 – fotografie č. 16



1

1 – fotografie č. 17

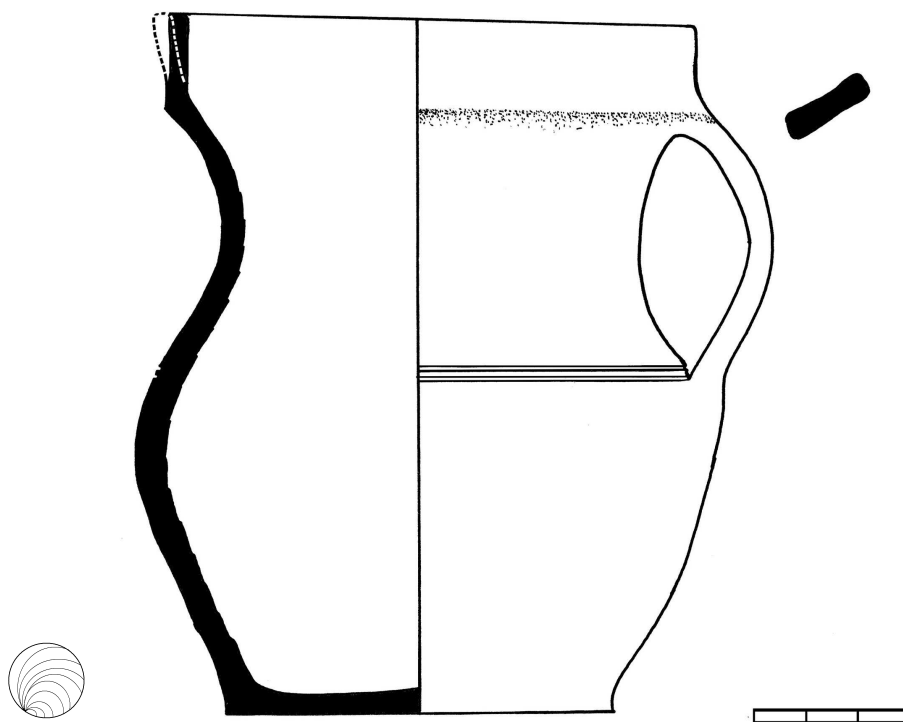

1 (1)

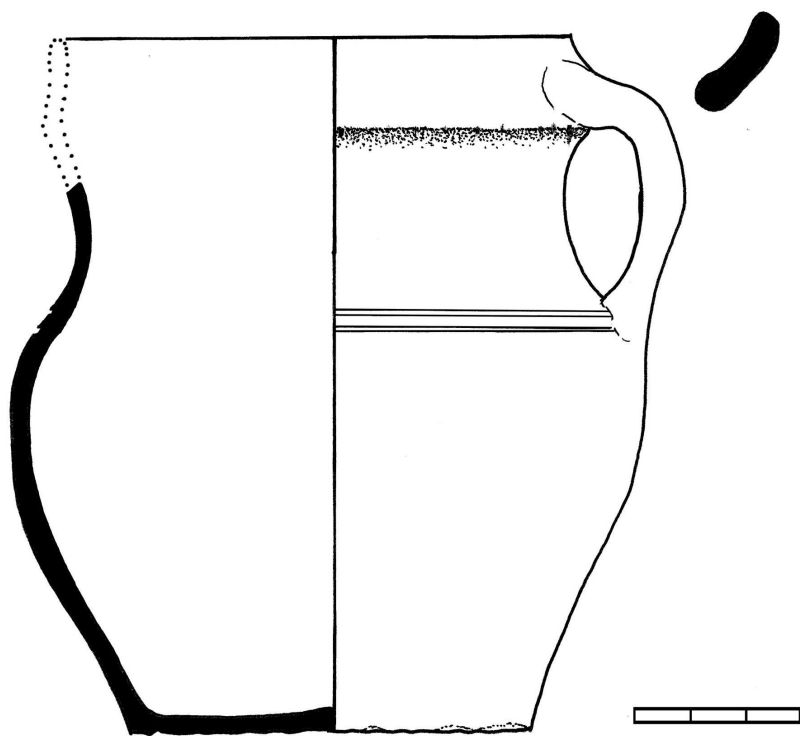

2 (2)

1-2 – keramické nálezy

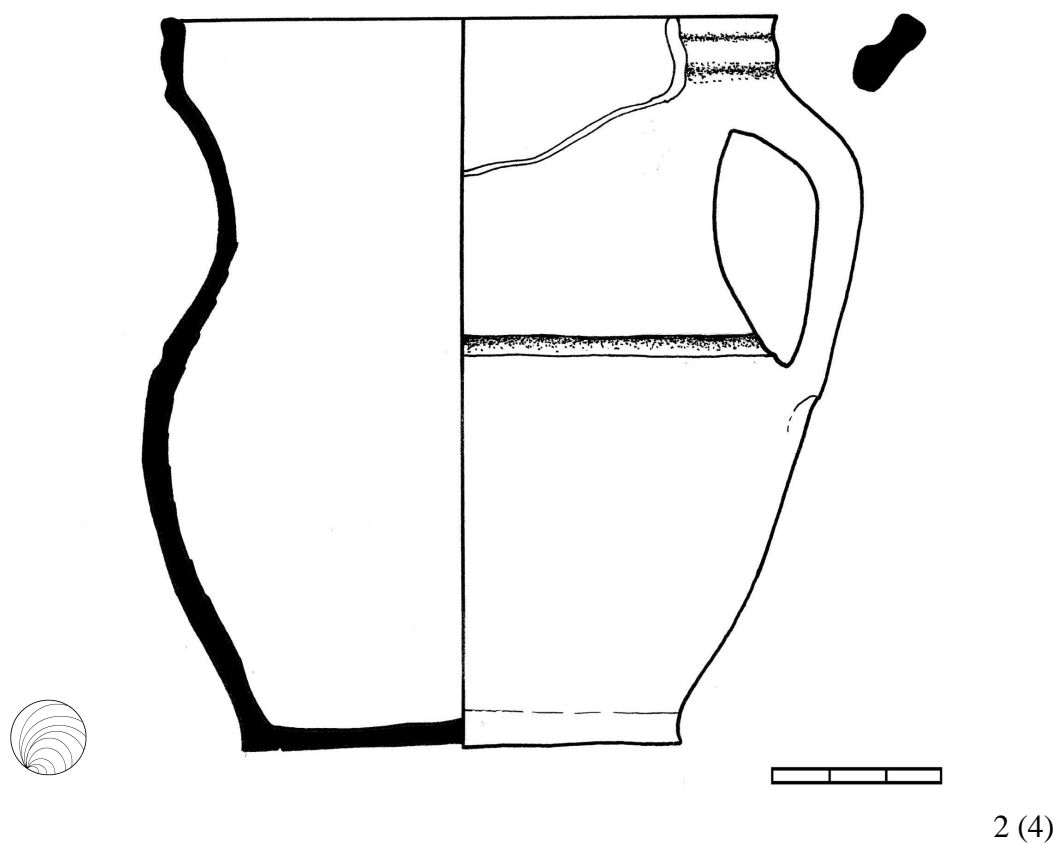
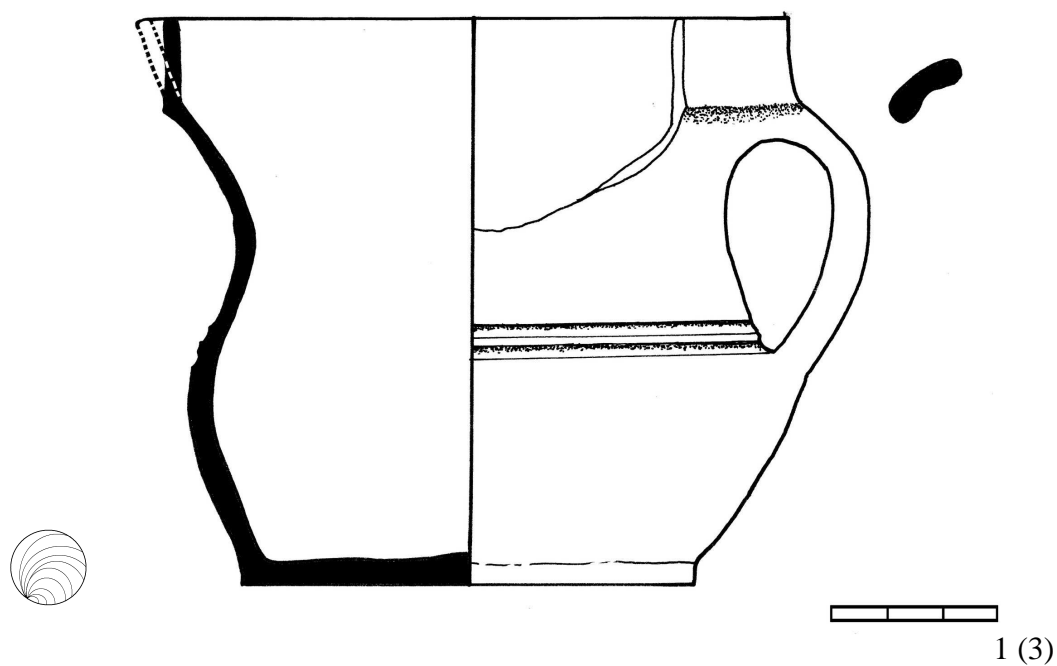

1-2 – keramické nálezy

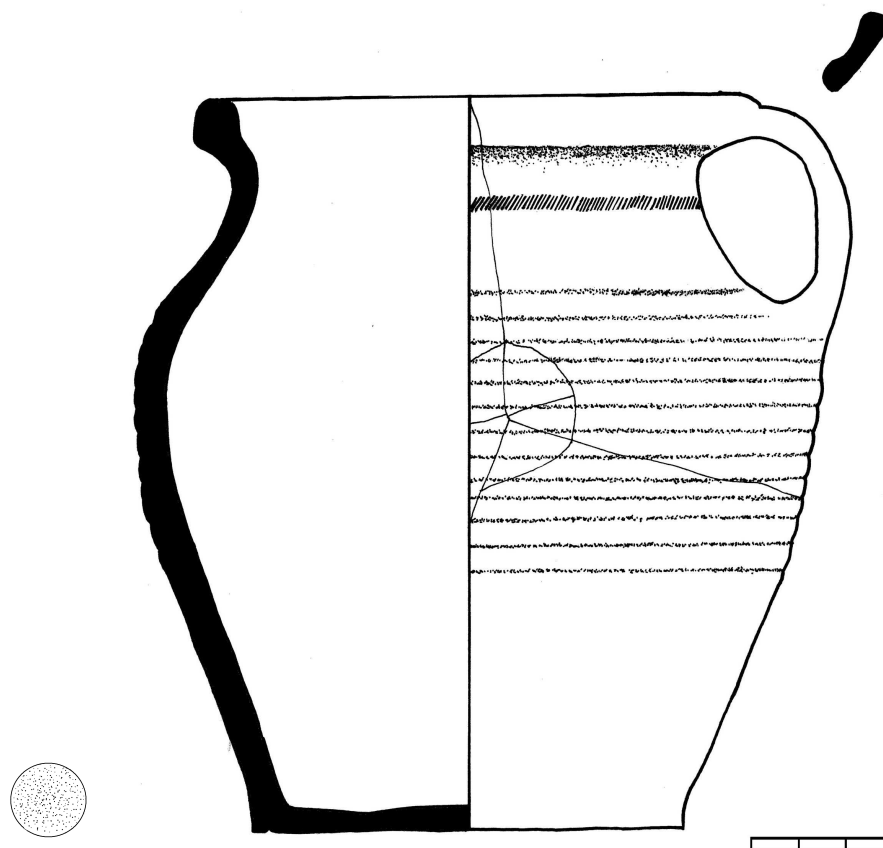

1 (5)

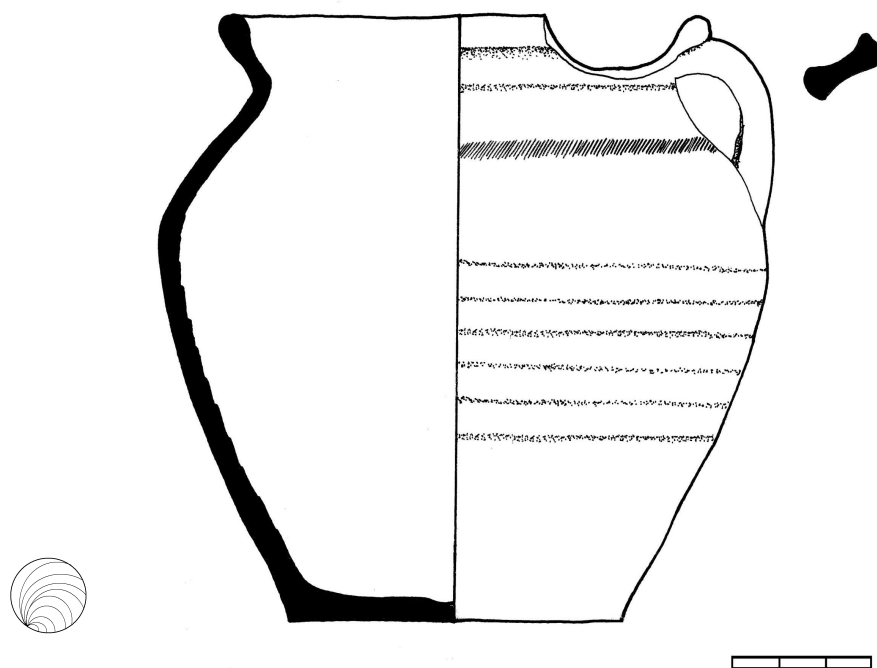

2 (6)

1-2 – keramické nálezy

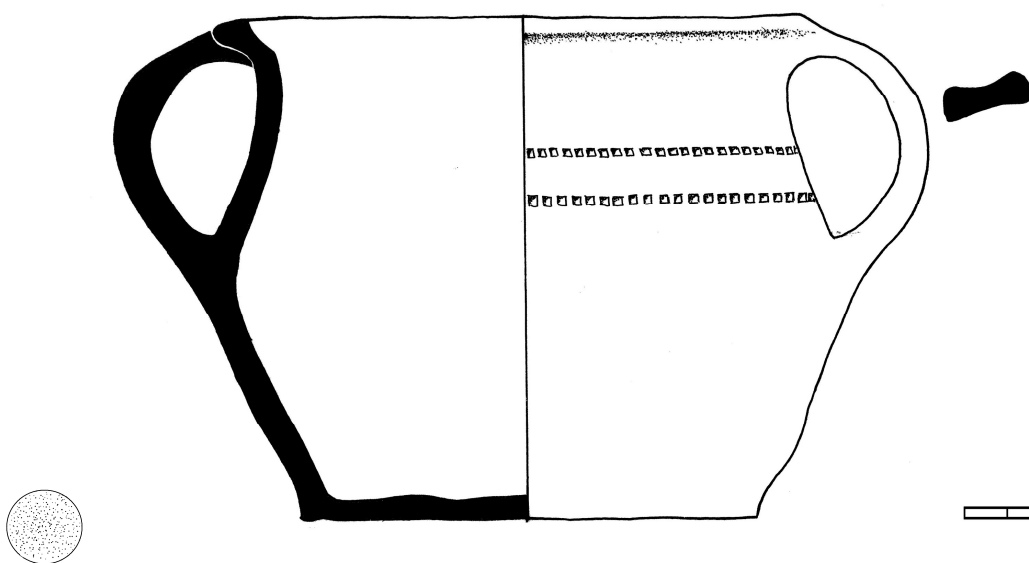

1 (7)

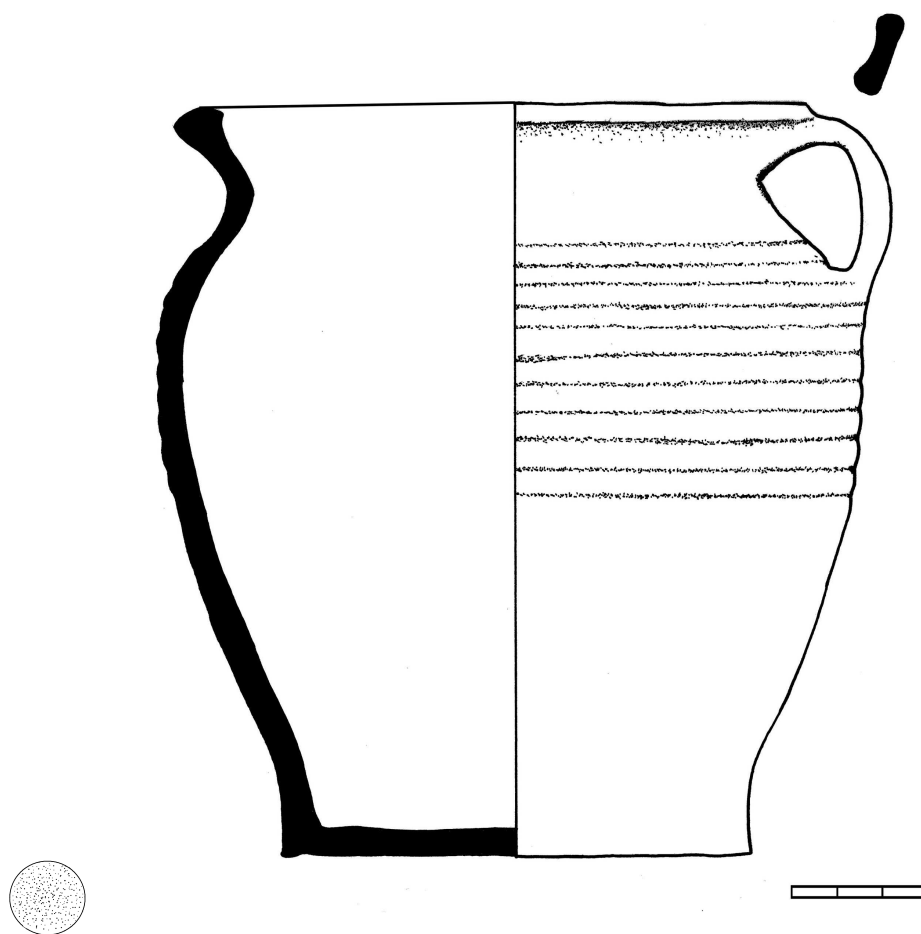

2 (8)

1-2 – keramické nálezy

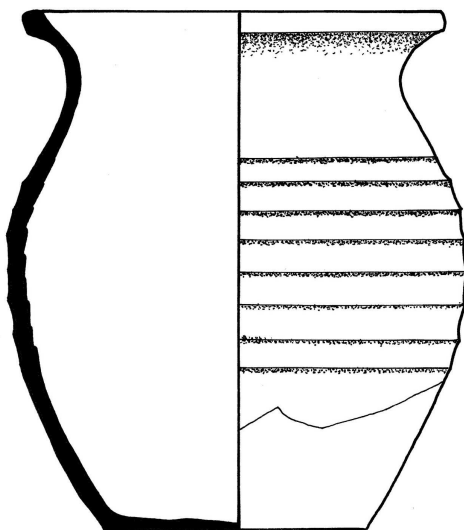

1 (9)

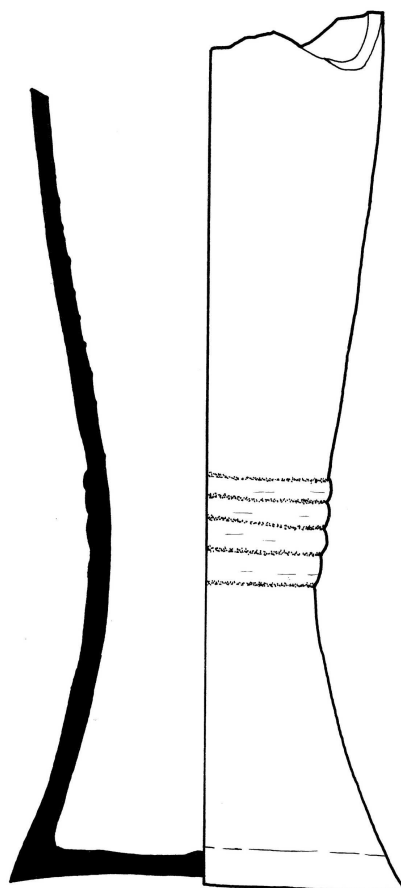

2 (10)

1-2 – keramické nálezy

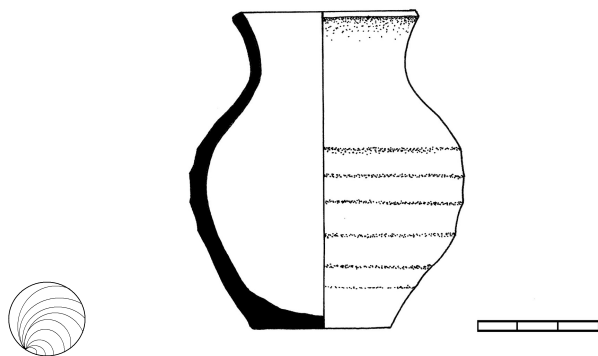

1 (12)

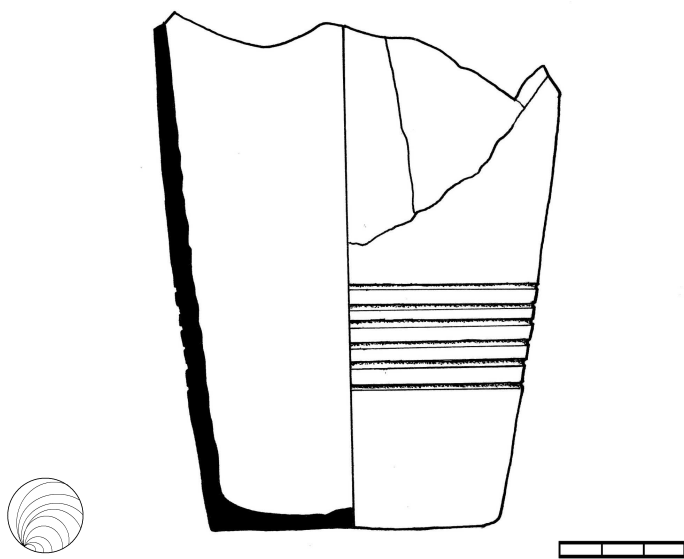

2 (11)

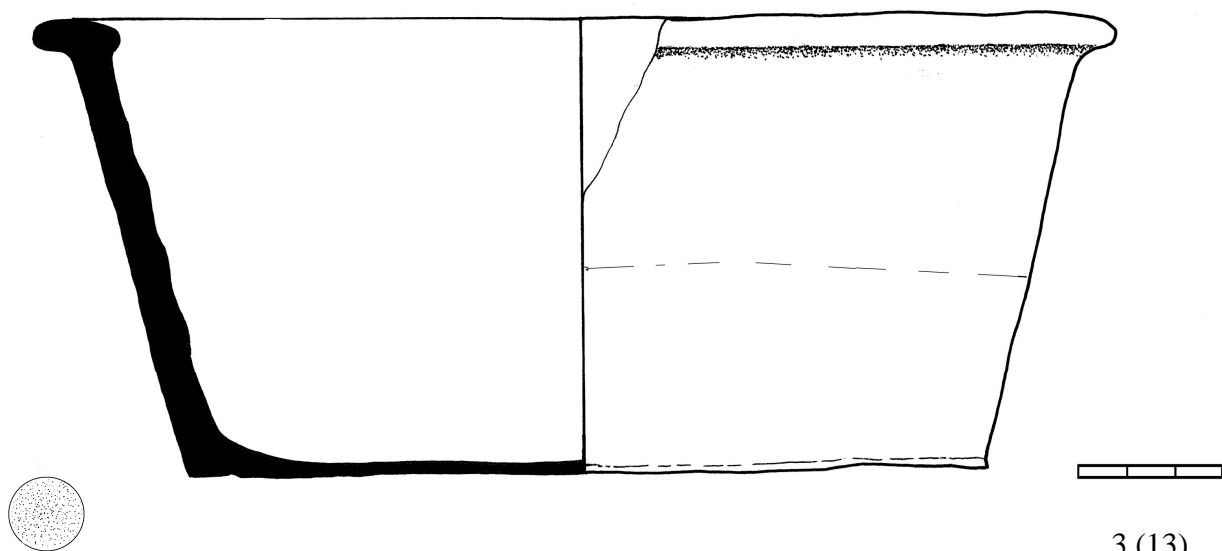

3 (13)

1-3 – keramické nálezy

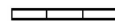
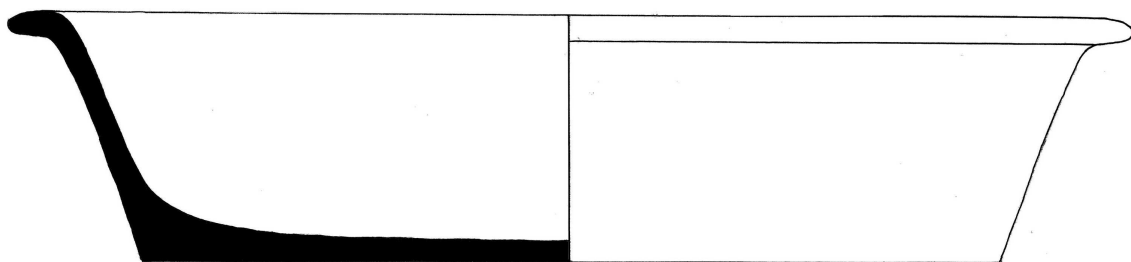

1 (14)

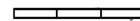
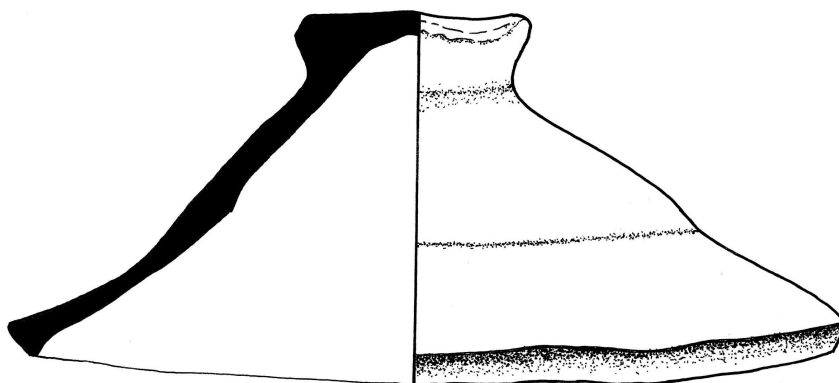

2 (15)

1-2 – keramické nálezy

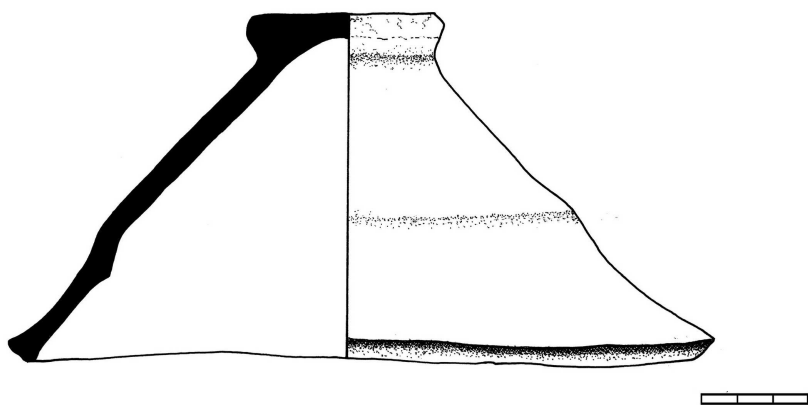

1 (17)

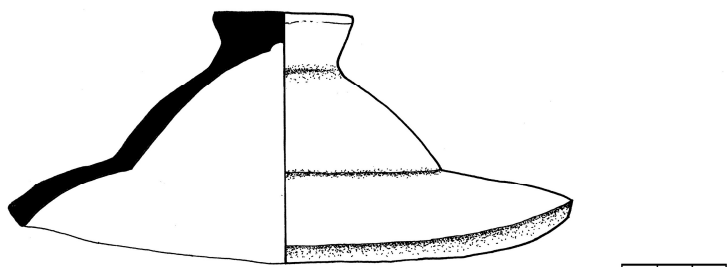

2 (16)

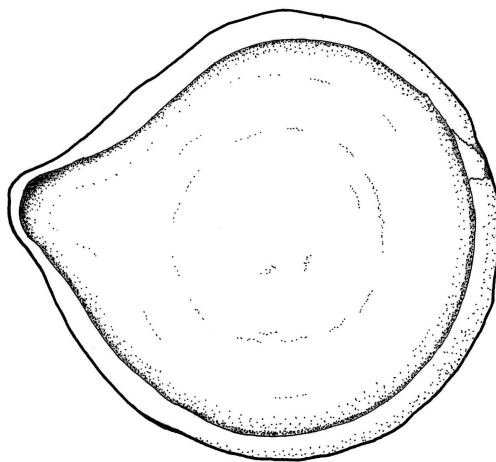

3 (18)

1-3 – keramické nálezy

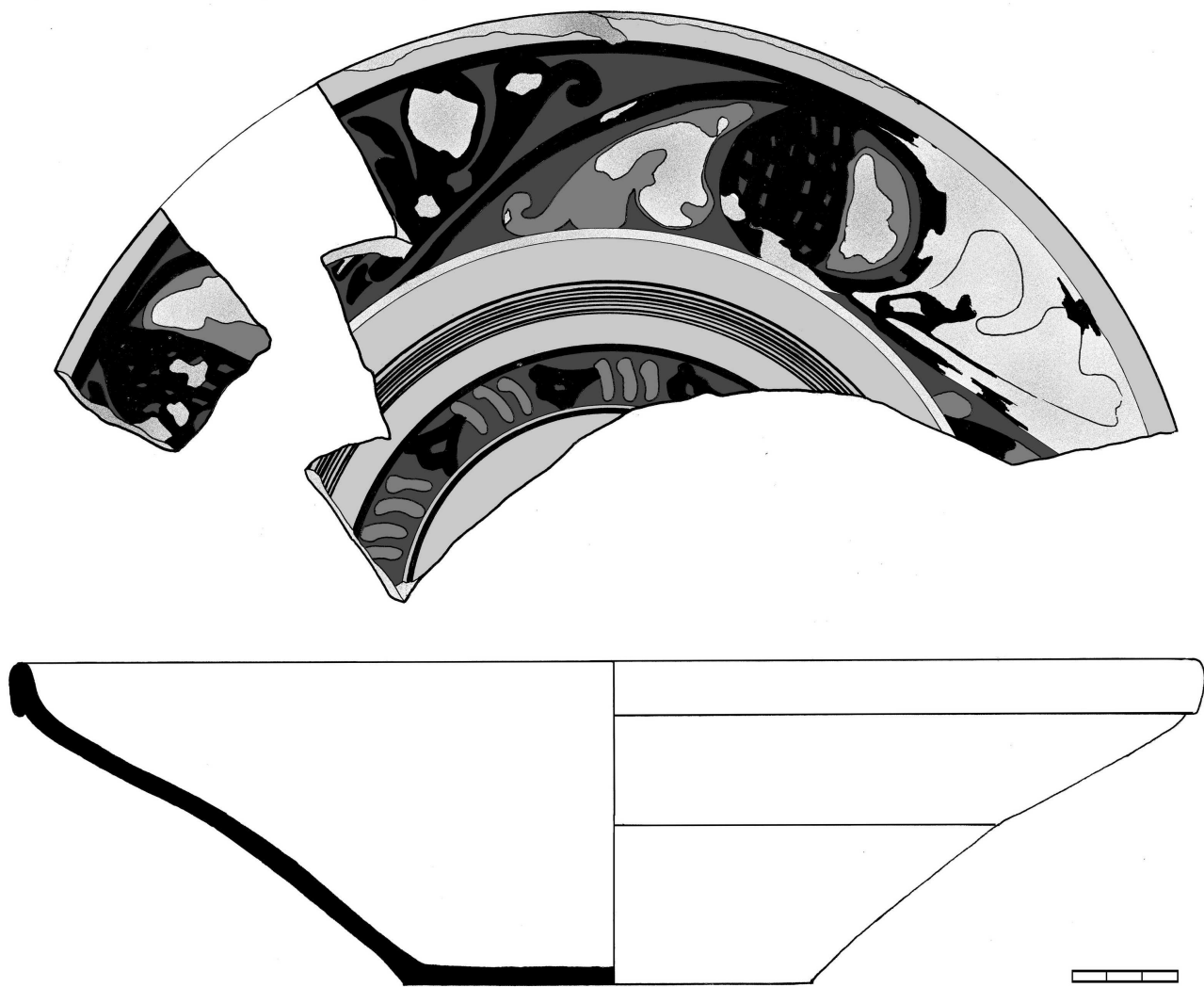

1 (19)

-  původní povrch
-  okrová
-  zelená
-  hnědá
-  bílá

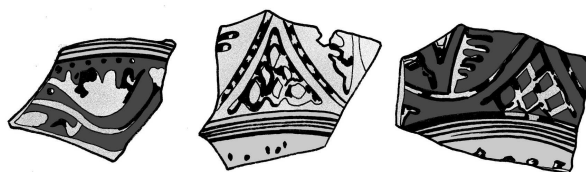

 2 (20)

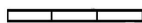
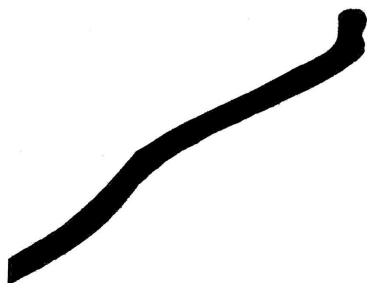
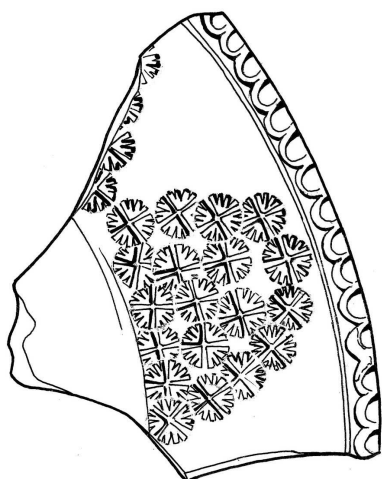

1 (21)



2 (22)

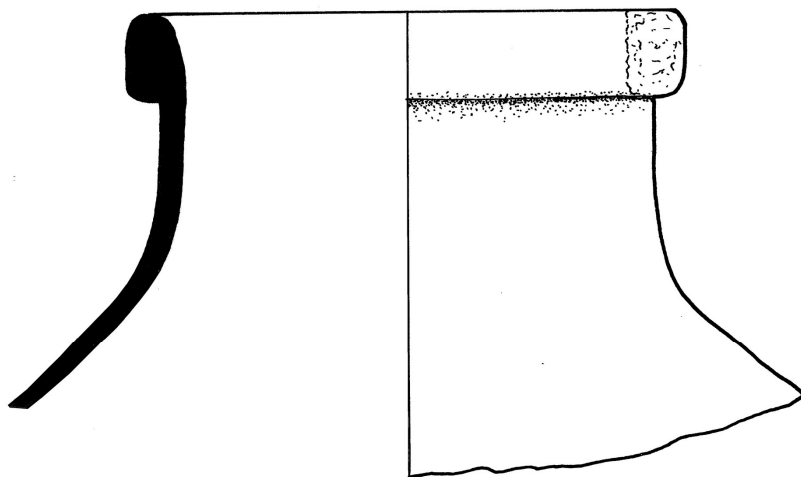

3 (23)

1-3 – keramické nálezy

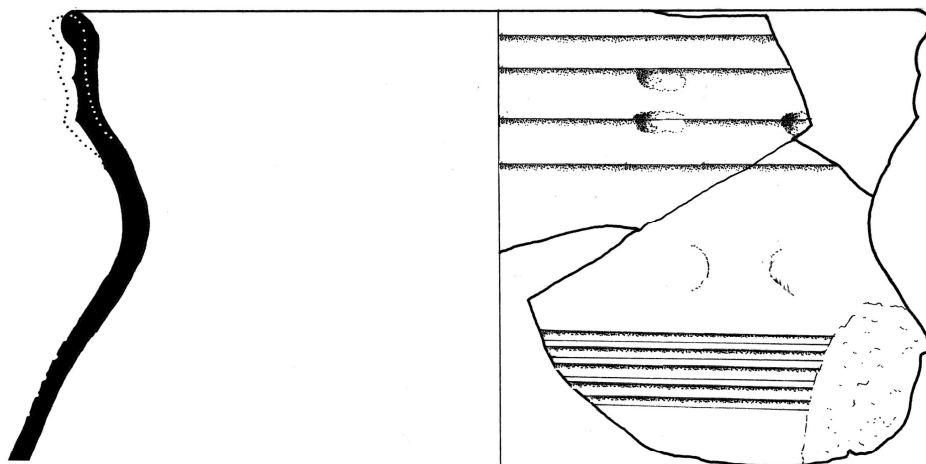

1 (24)

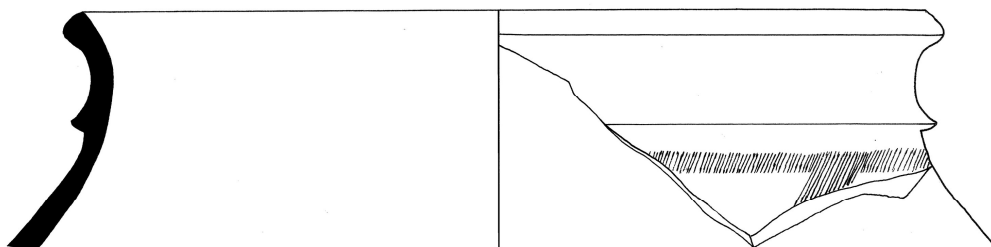

2 (25)

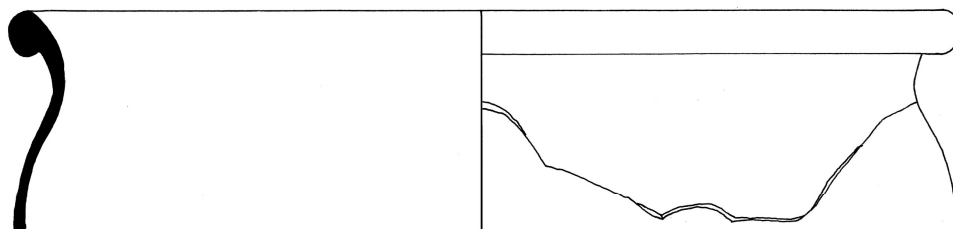

3 (26)

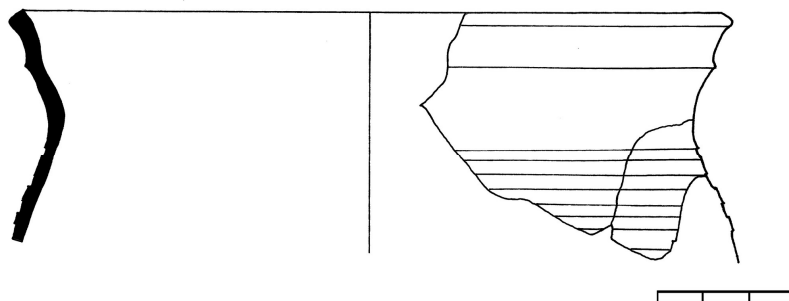

4 (27)

1-4 – keramické nálezy

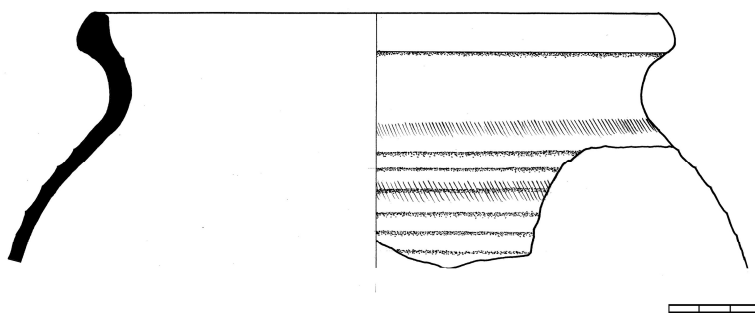

1 (28)

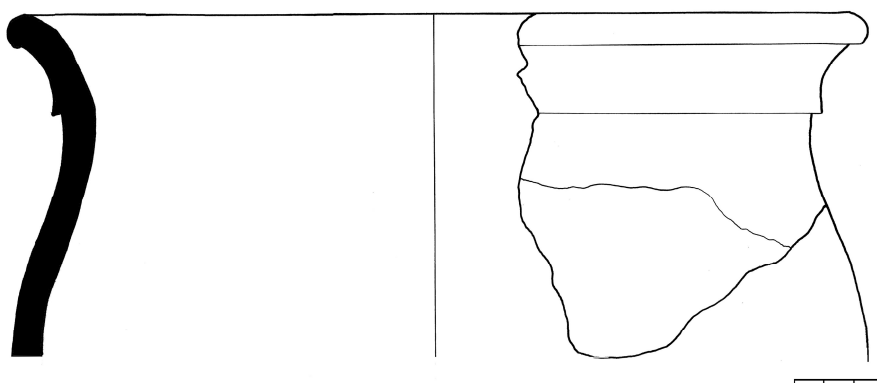

2 (29)

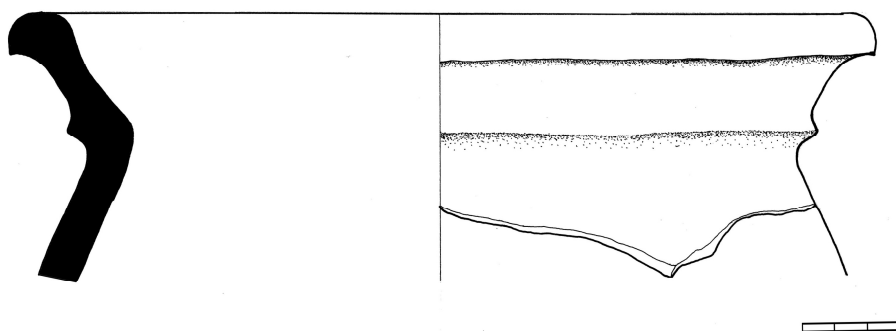

3 (30)

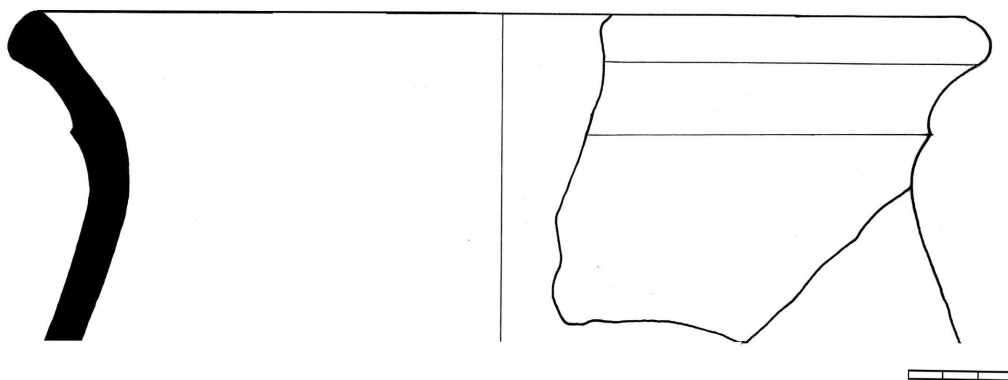

4 (31)

1-4 – keramické nálezy



1 (32)

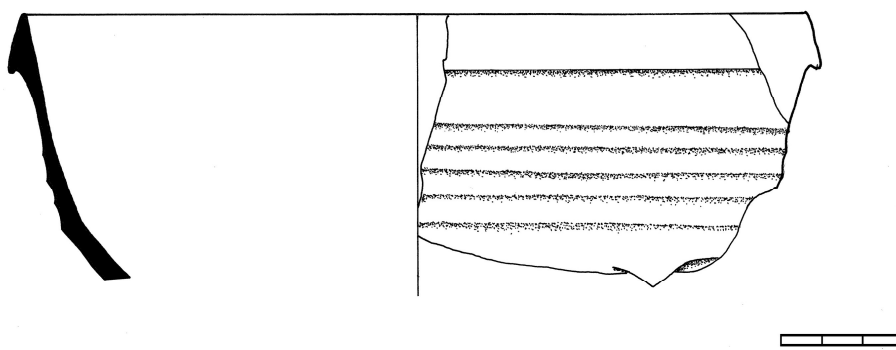

2 (34)

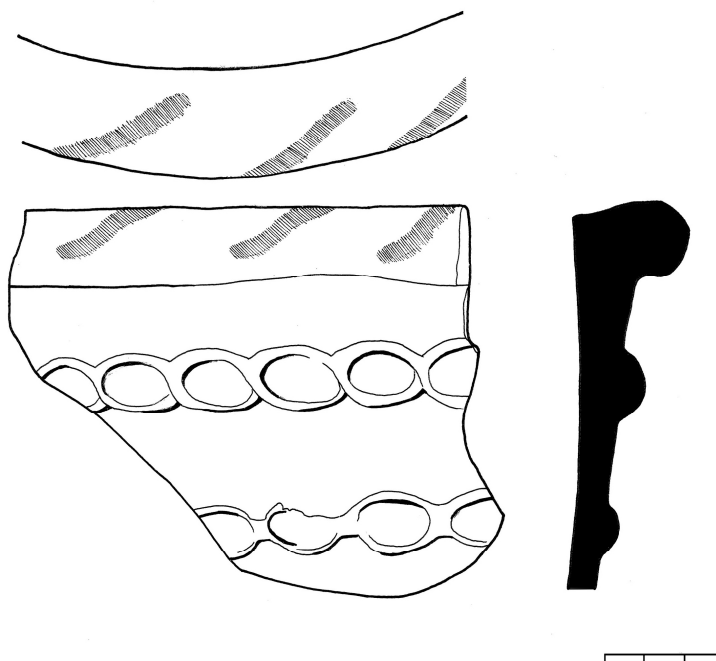

3 (33)

1-3 – keramické nálezy

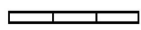
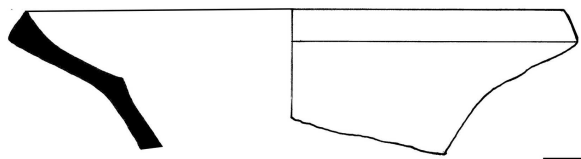

1 (35)

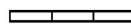
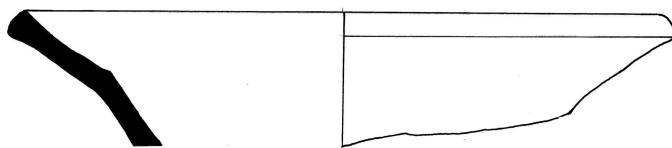

2 (36)

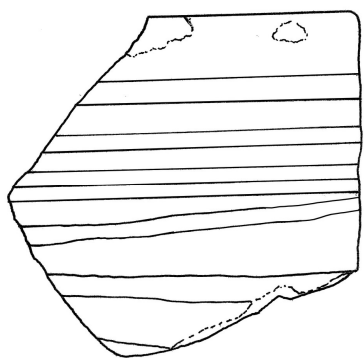

3 (37)

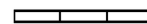
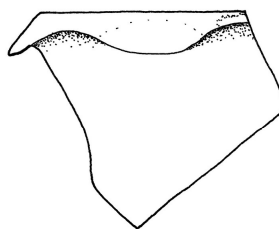

4 (40)

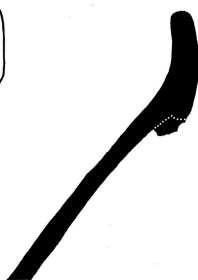
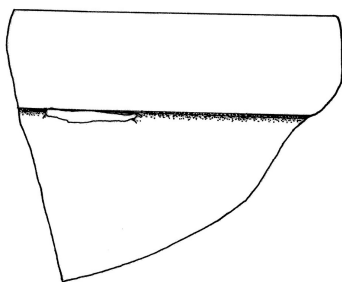

5 (39)

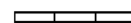
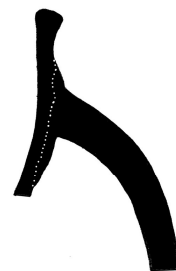
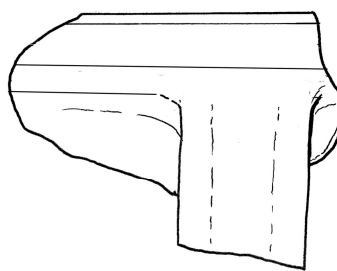

6 (38)

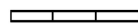
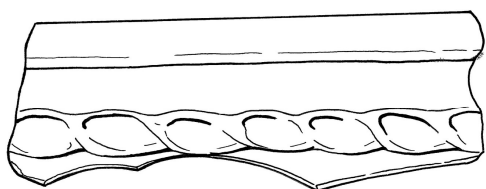

7 (41)

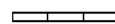
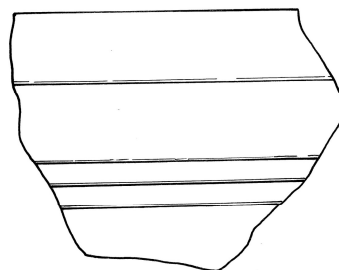

8 (42)

1-8 – keramické nálezy

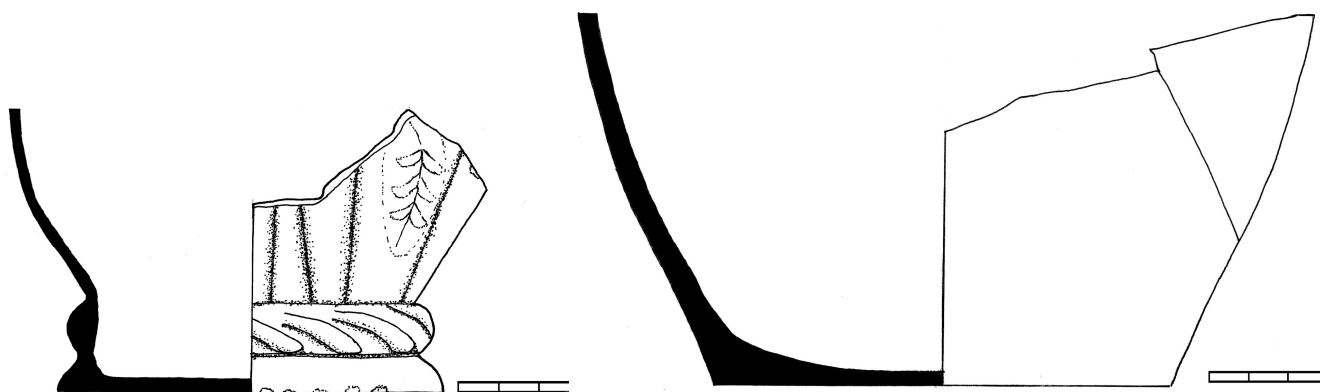

1 (45)

2 (46)

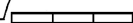
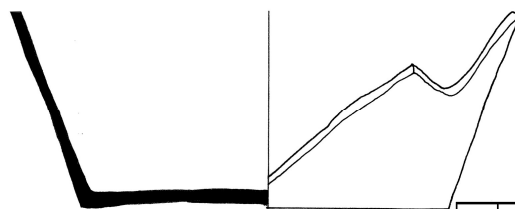
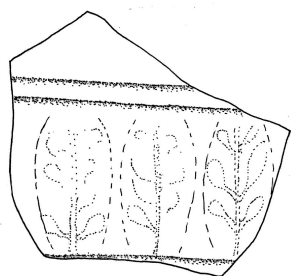

3 (45)

4 (47)

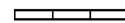
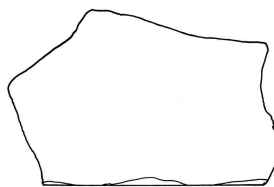
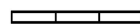
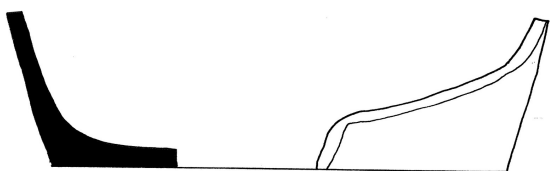

5 (48)

6 (49)

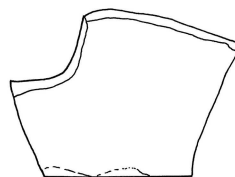
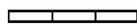
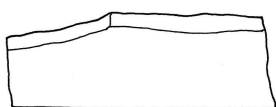

7 (50)

8 (51)

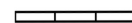
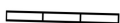

9 (43)

10 (44)

1-10 – keramické nálezy

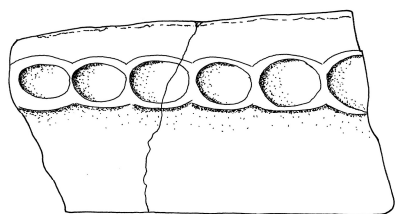

1 (52)

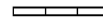
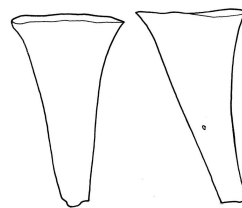

2 (55)

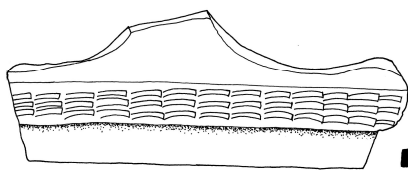

3 (53)

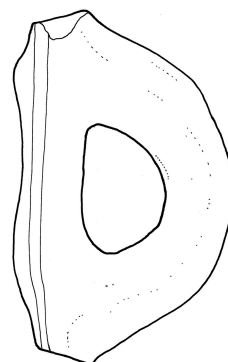

4 (59)

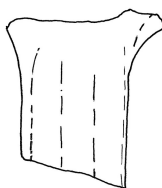

5 (57)

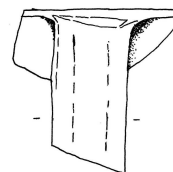

6 (56)

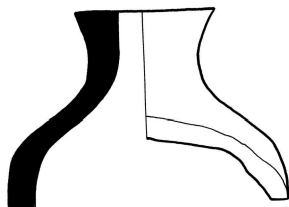

7 (61)

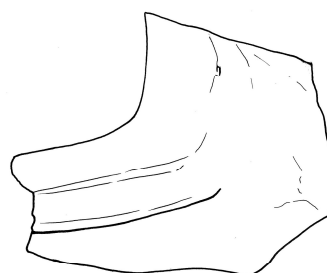

8 (60)

1-8 – keramické nálezy

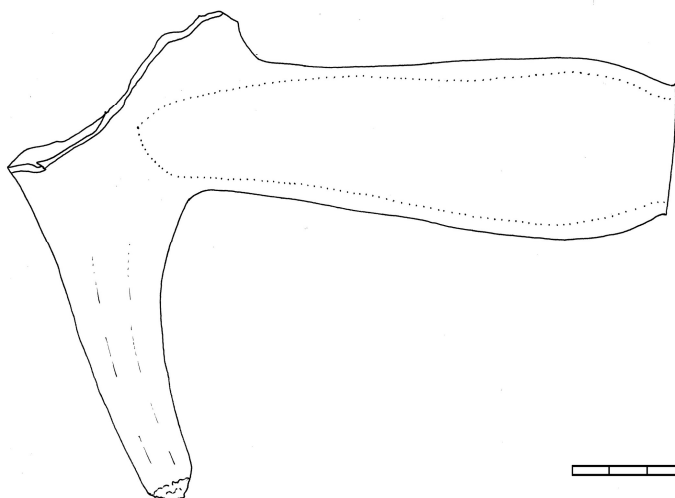

1 (63)

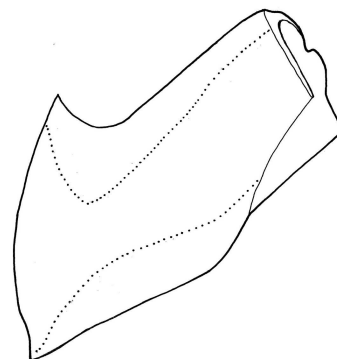

2 (64)

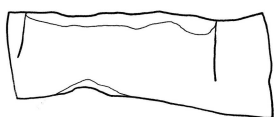

3 (62)

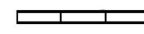

4 (65)

- | | |
|---|-----------------------|
|  | bílá |
|  | původní povrch |
|  | šedozelená |
|  | okrová |
|  | zelená |
|  | modrá |
|  | hnědá |

1-4 – keramické nálezy

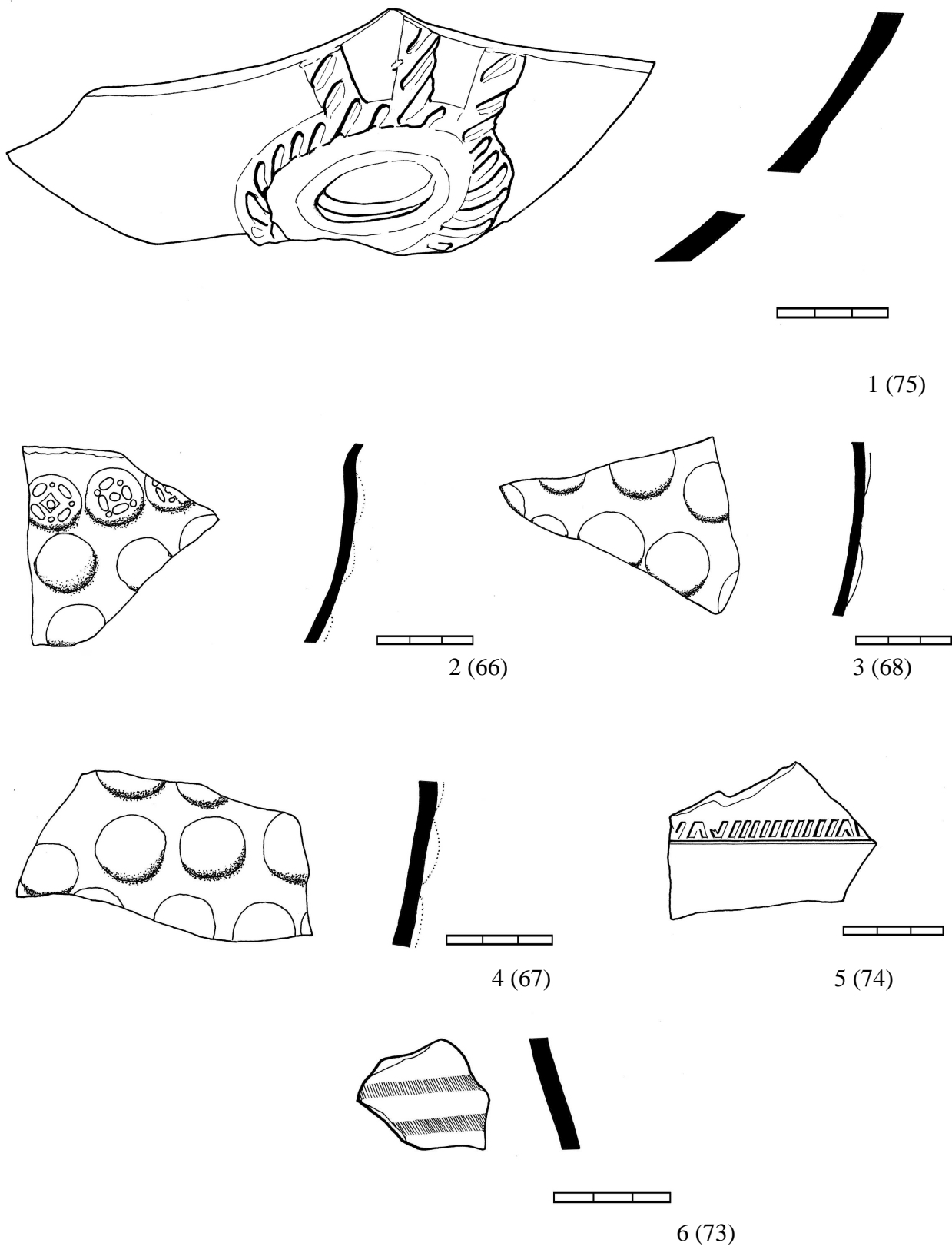

1-6 – keramické nálezy

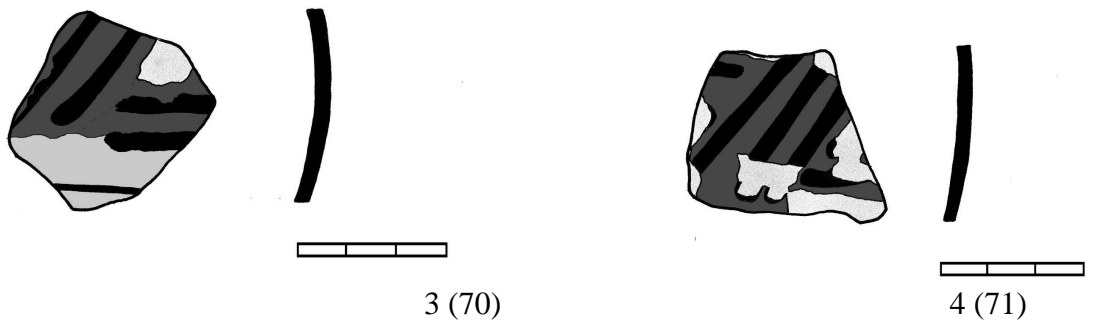
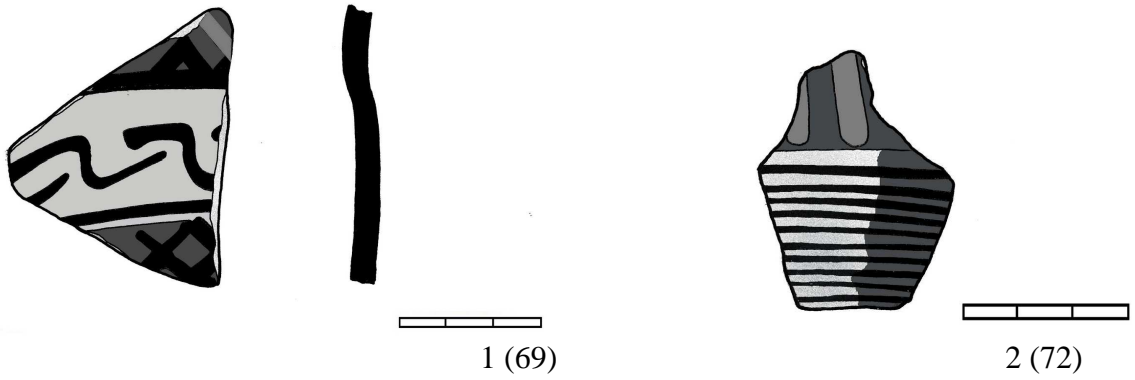



1 – Kachel

1 (84)

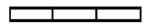
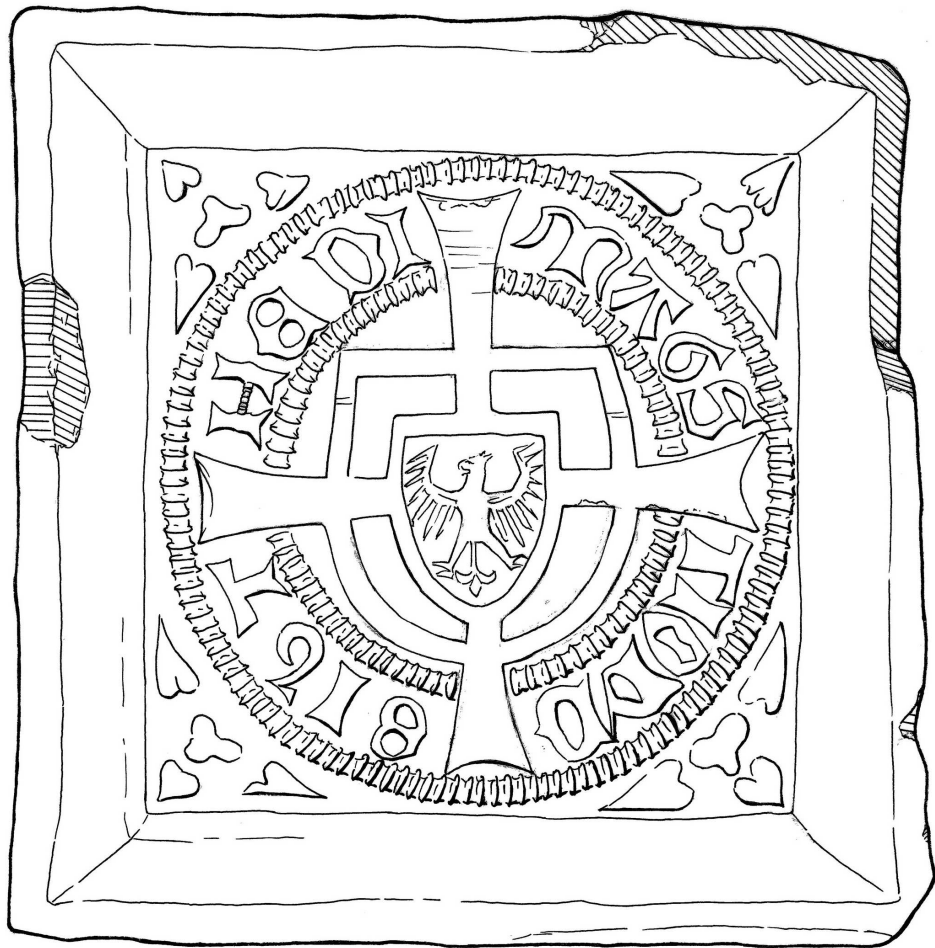

1 (85)

1 – Kachel



1 (86)

1 – Kachel

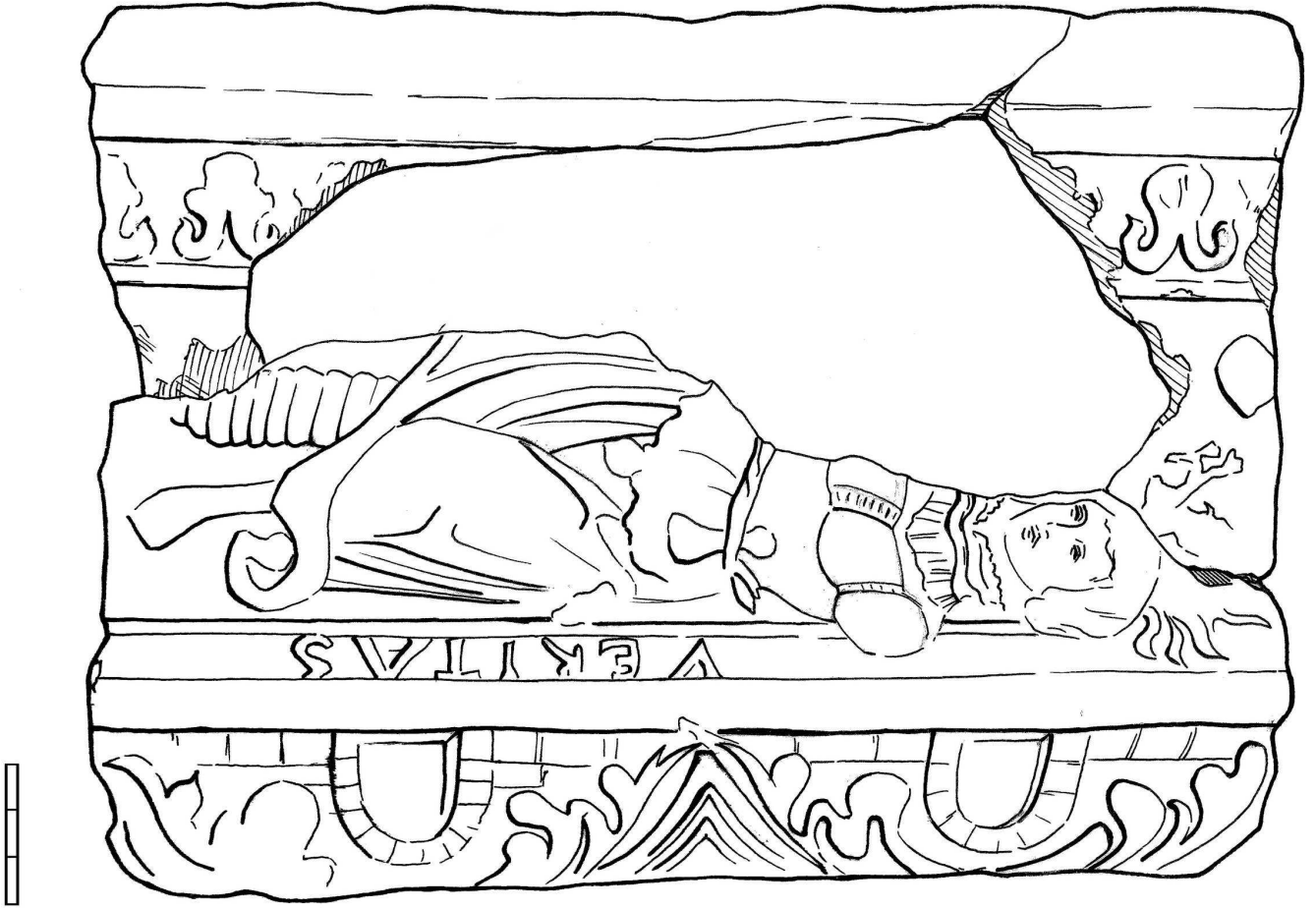

1 (87)



2 (88)

1-2 – kachle

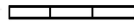
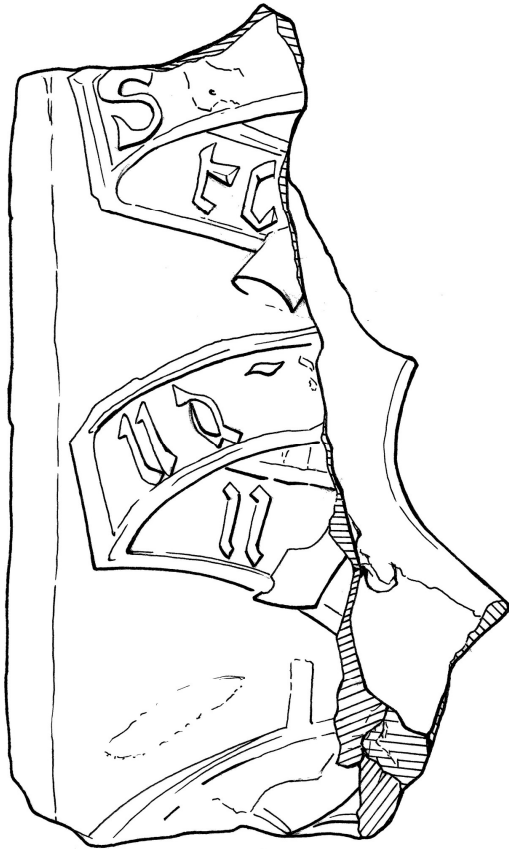

1 (89)

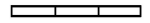

2 (90)

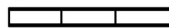
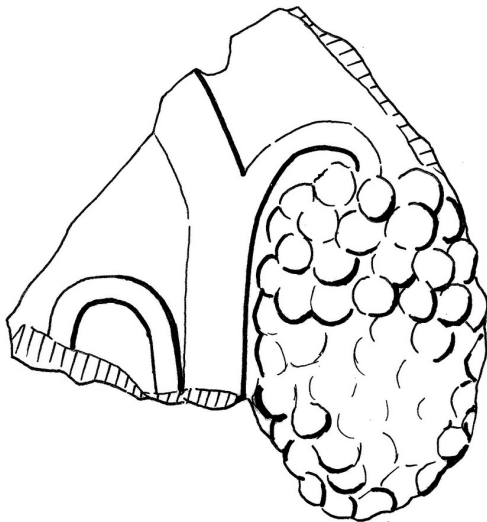

3 (91)

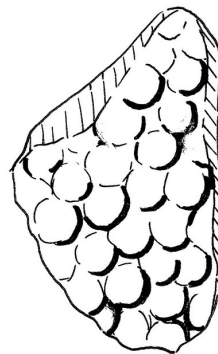

4 (92)

1-4 – kachle

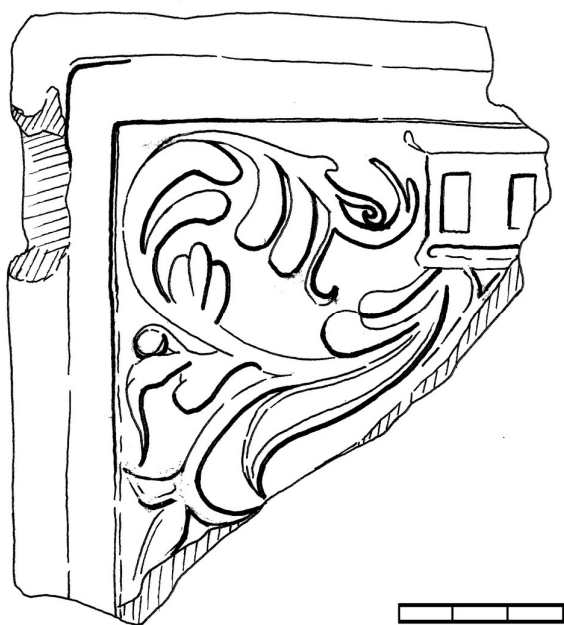

1 (93)



2 (94)

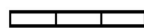
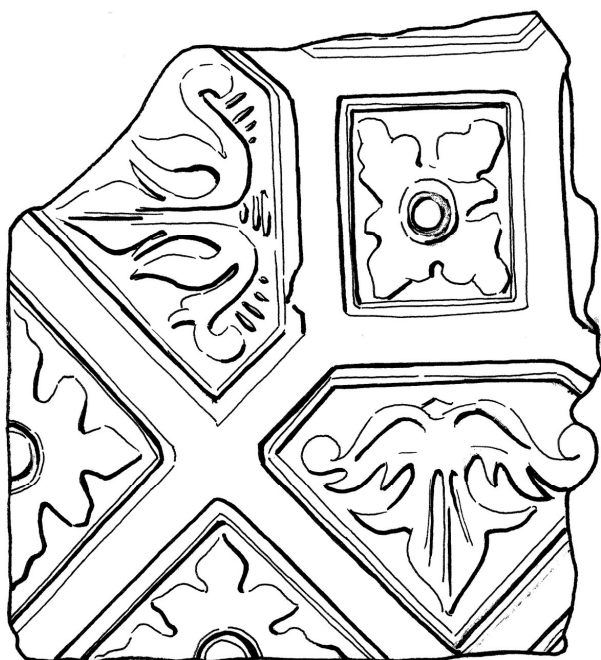

3 (95)

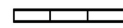
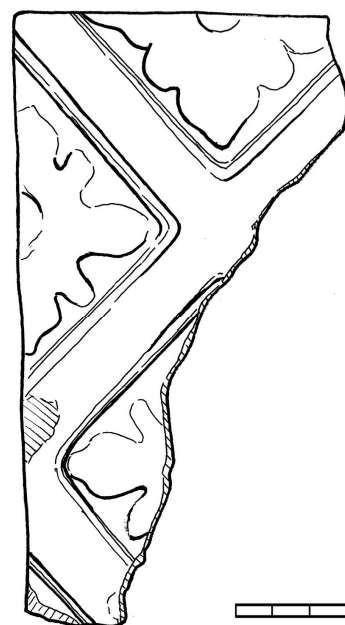

4 (96)

1-4 – kachle

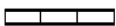
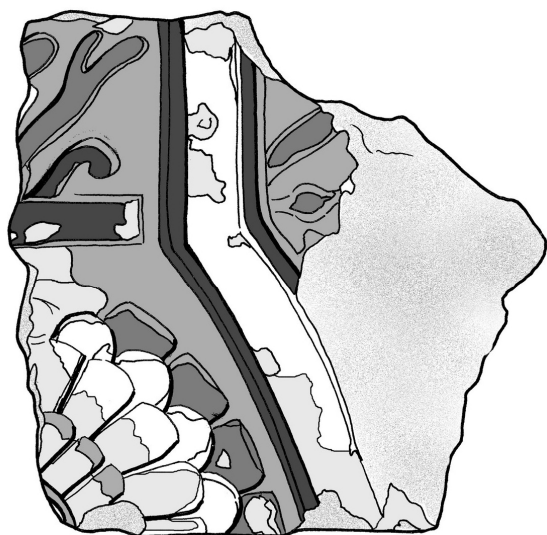

1 (98)

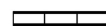
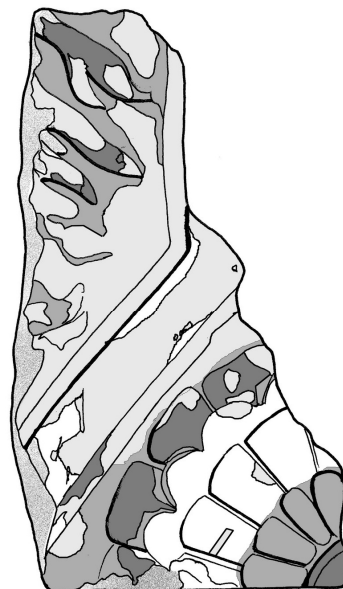

2 (99)

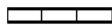
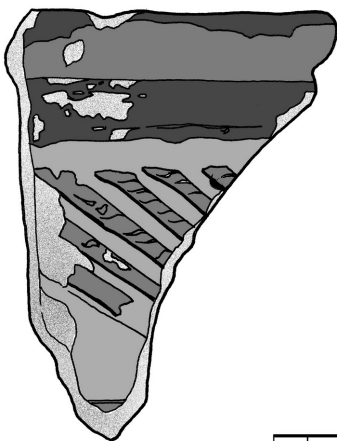

3 (100)

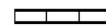
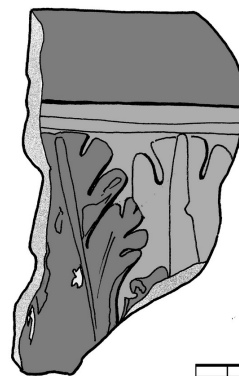

4 (101)

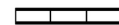
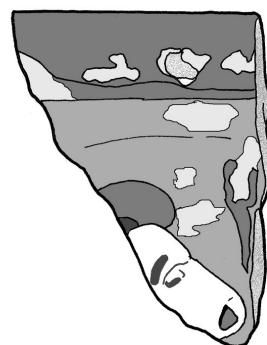

5 (102)

-  bílá
-  původní povrch
-  engoba
-  žlutá
-  zelená
-  tmavě zelená

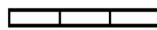
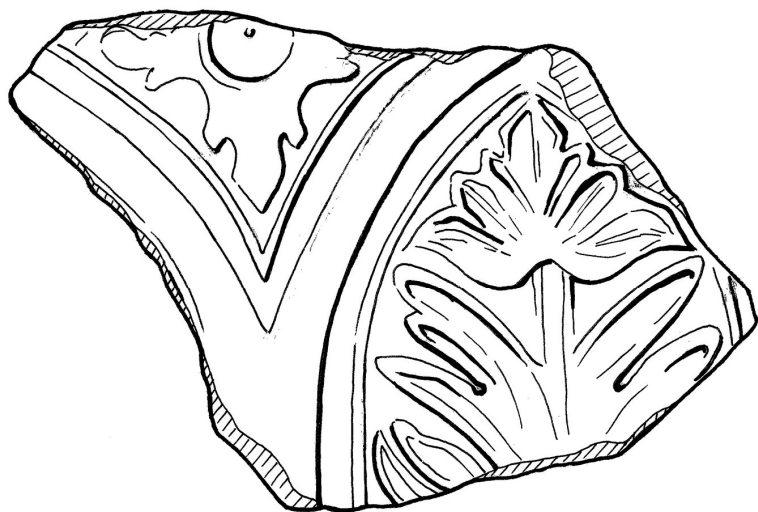

1 (97)

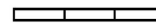
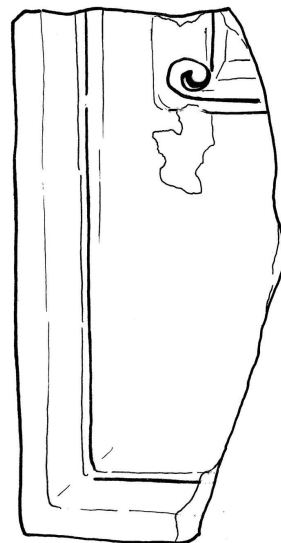

Obr 2 (103)

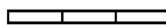
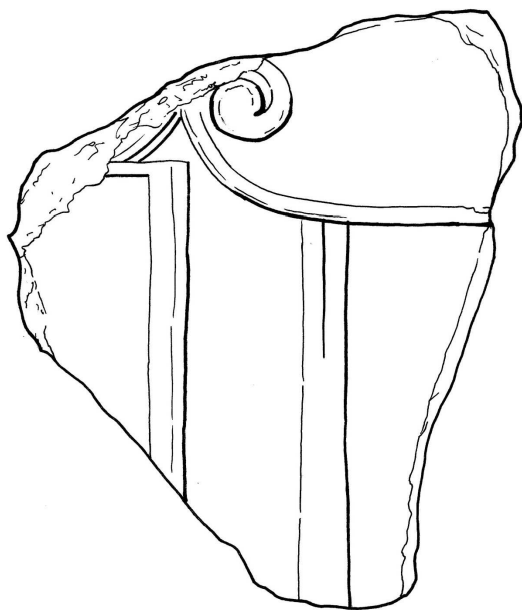

3 (104)

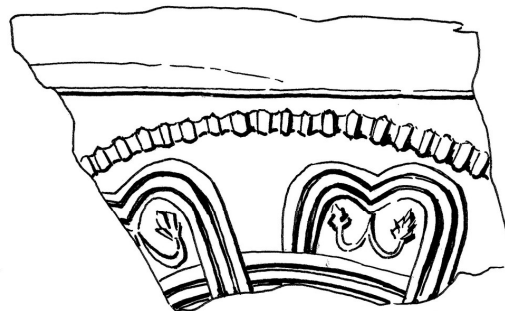

4 (105)

1-4 – kachle

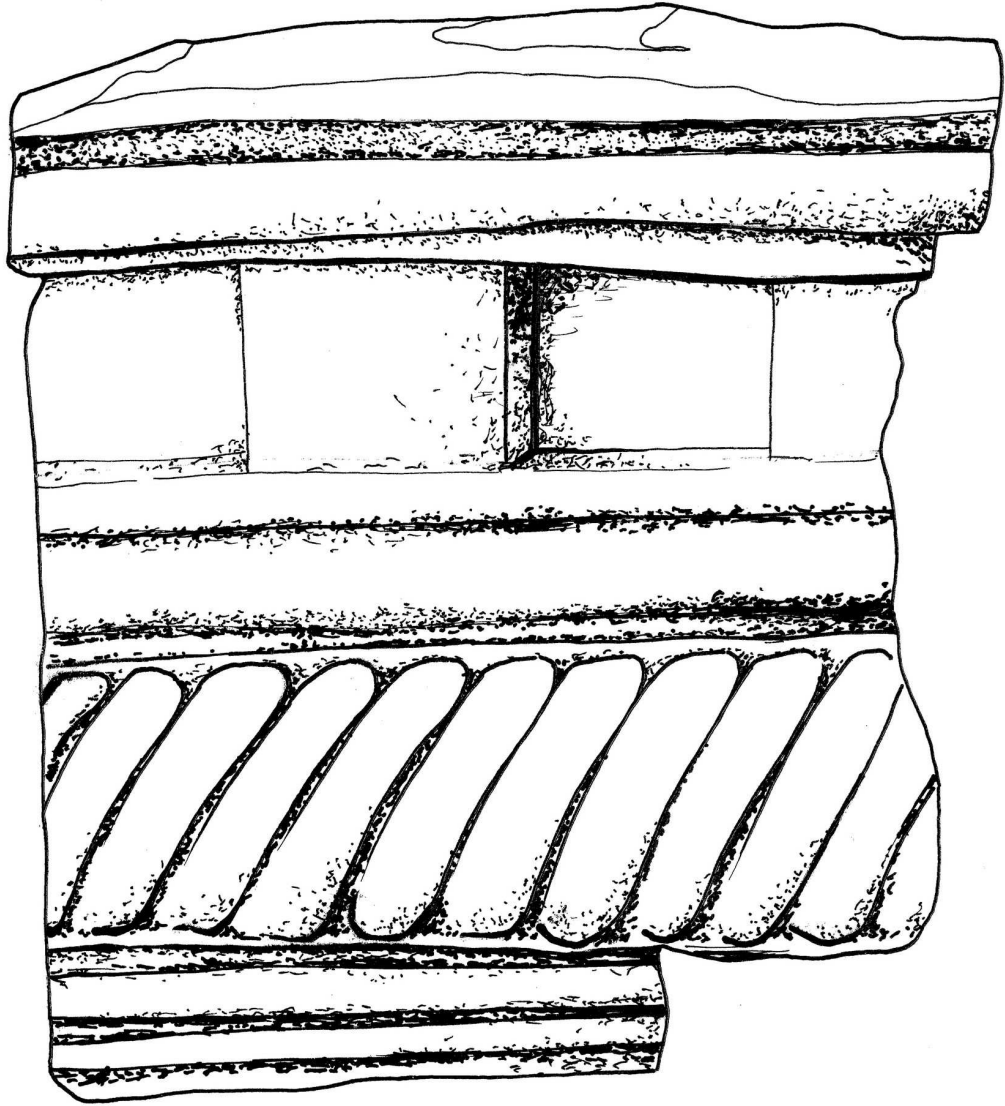

1 (108)

1 – kachel

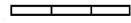
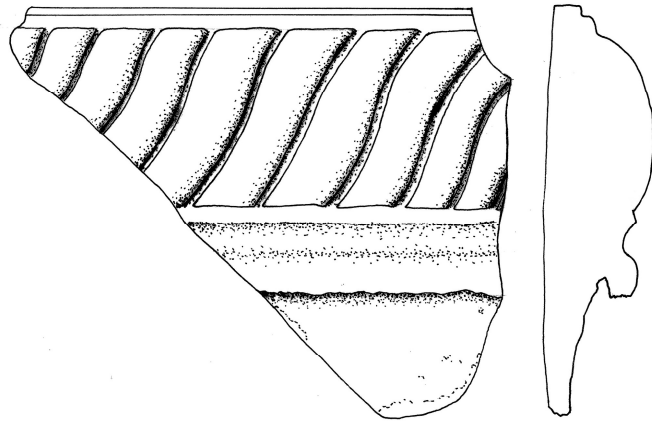

1 (106)

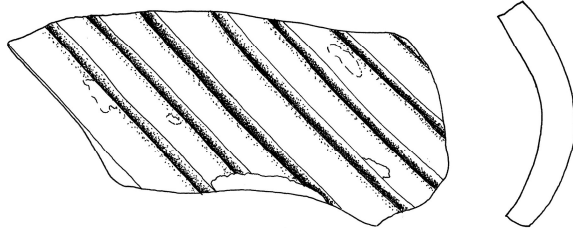

2 (109)

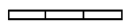
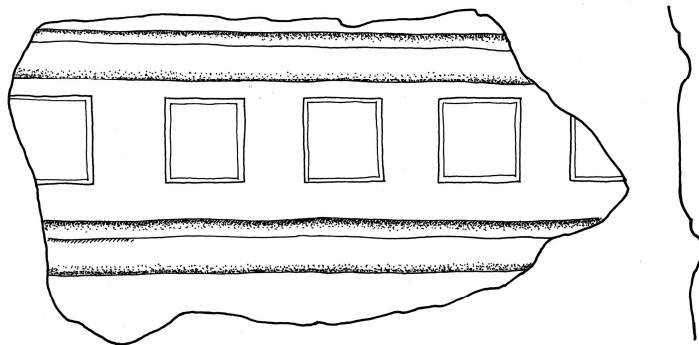

3 (110)

1-3 – kachle

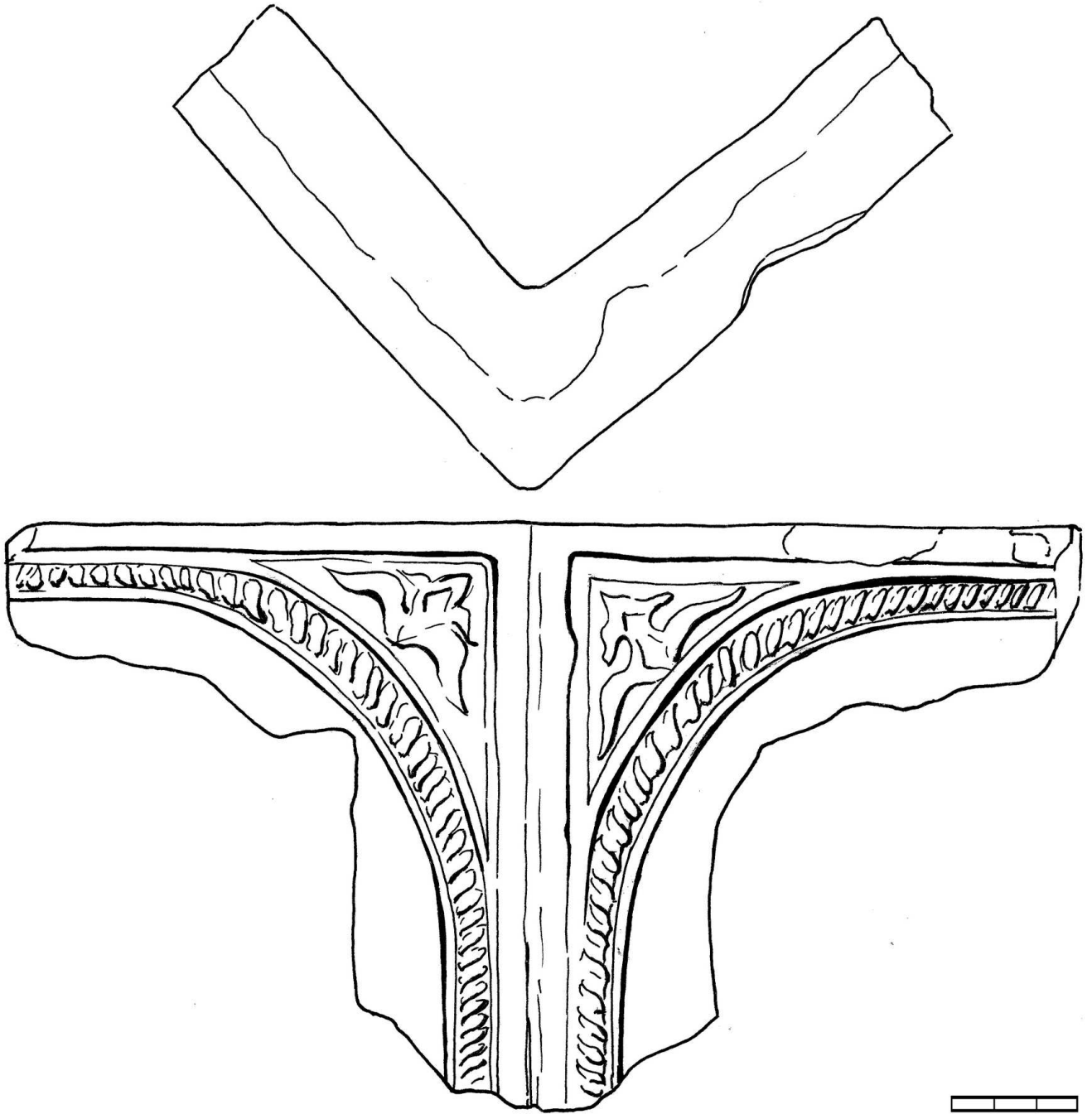

1 (111)

1 – kachel

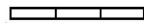
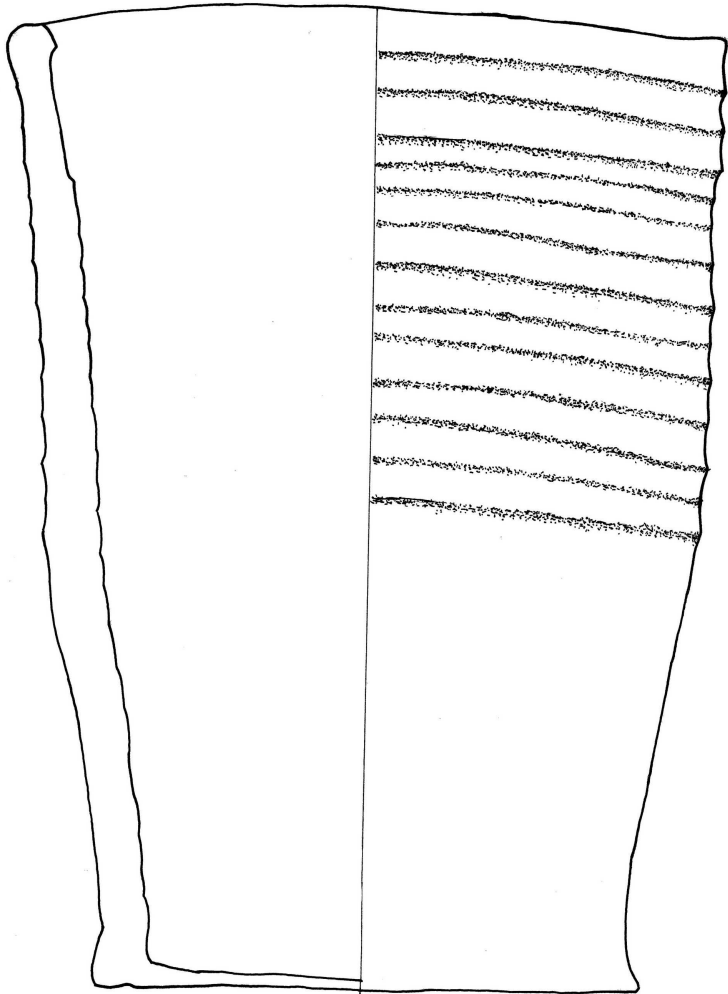
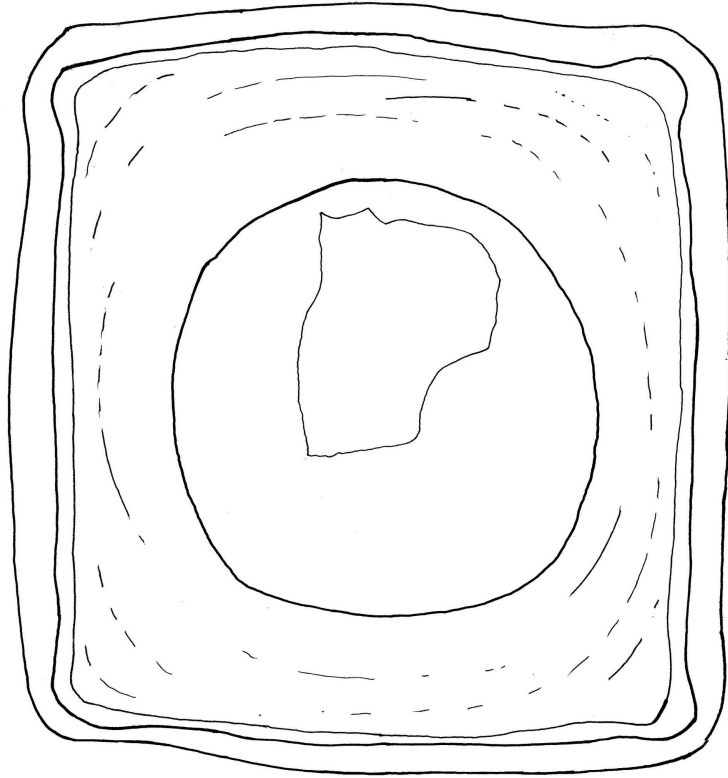

1 - kachel

1 (115)

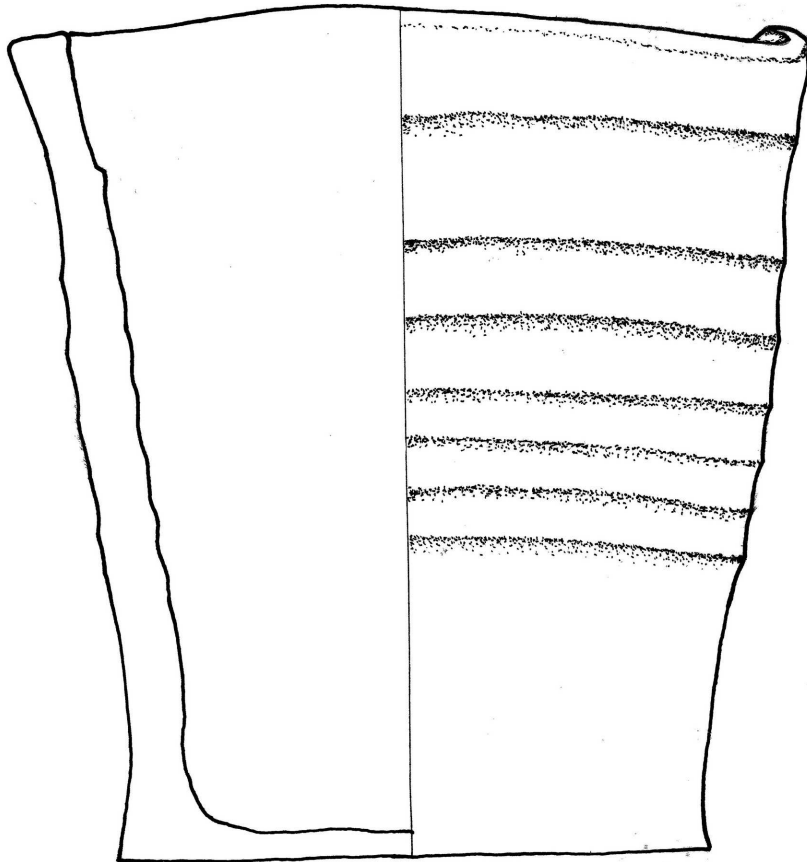
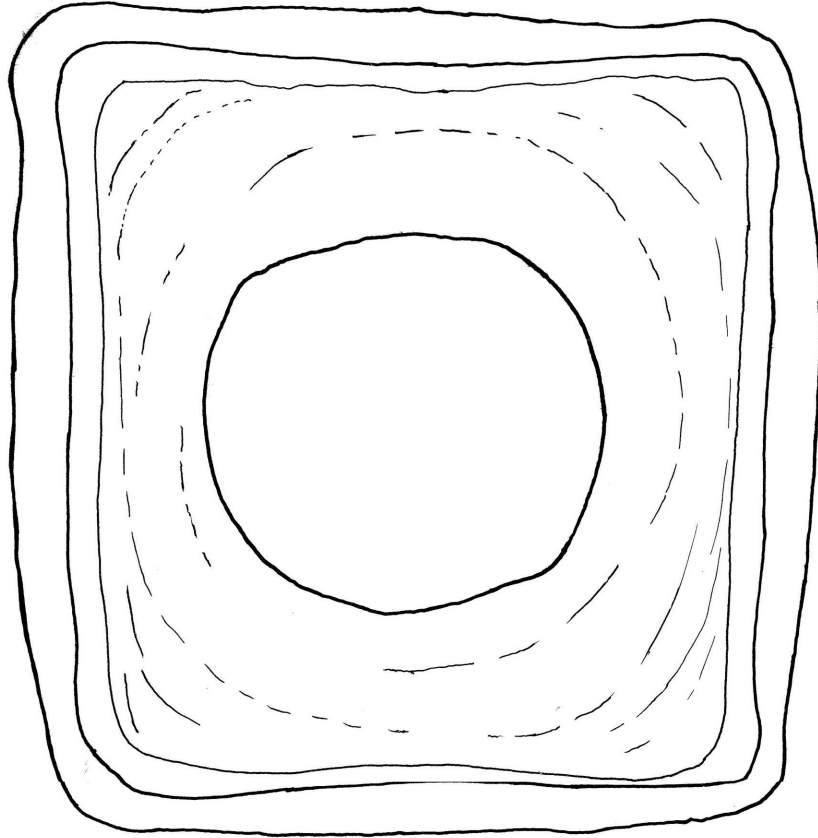

1 – kachel

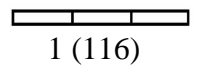

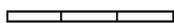
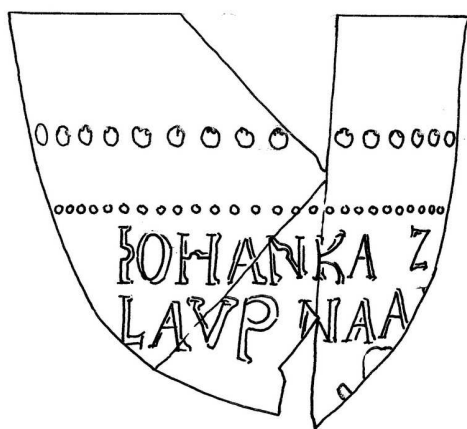

1 (118)

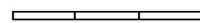

2 (120)

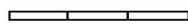
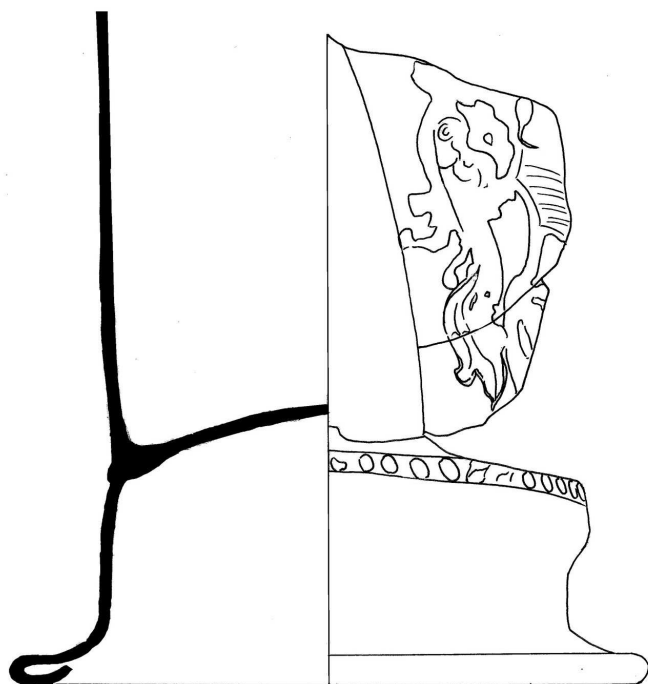

3 (119)

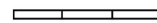

4 (121)

1-3 – skleněné nálezy

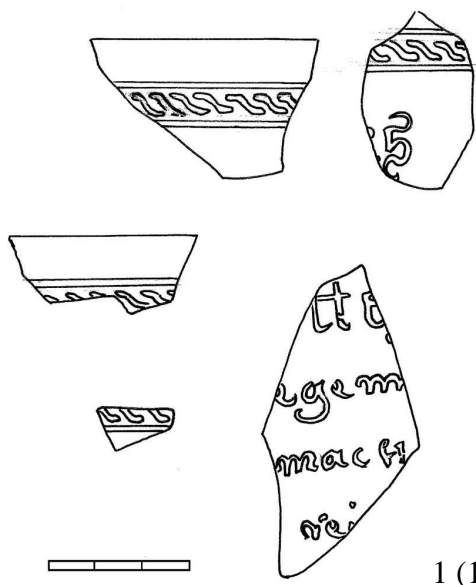

1 (123)

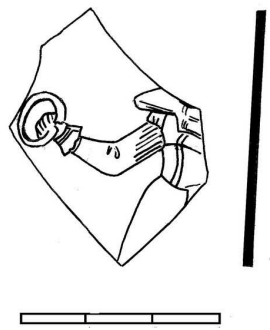

2 (122)

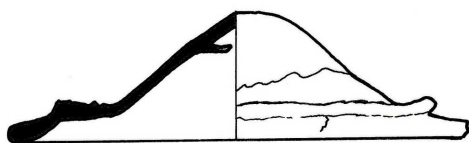

3. (124)

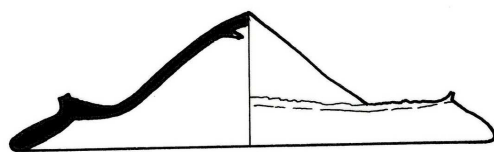

4 (125)

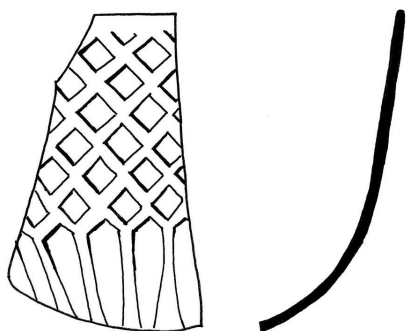

5 (126)

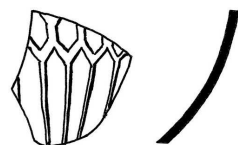

6 (127)

1-6 – skleněné nálezy

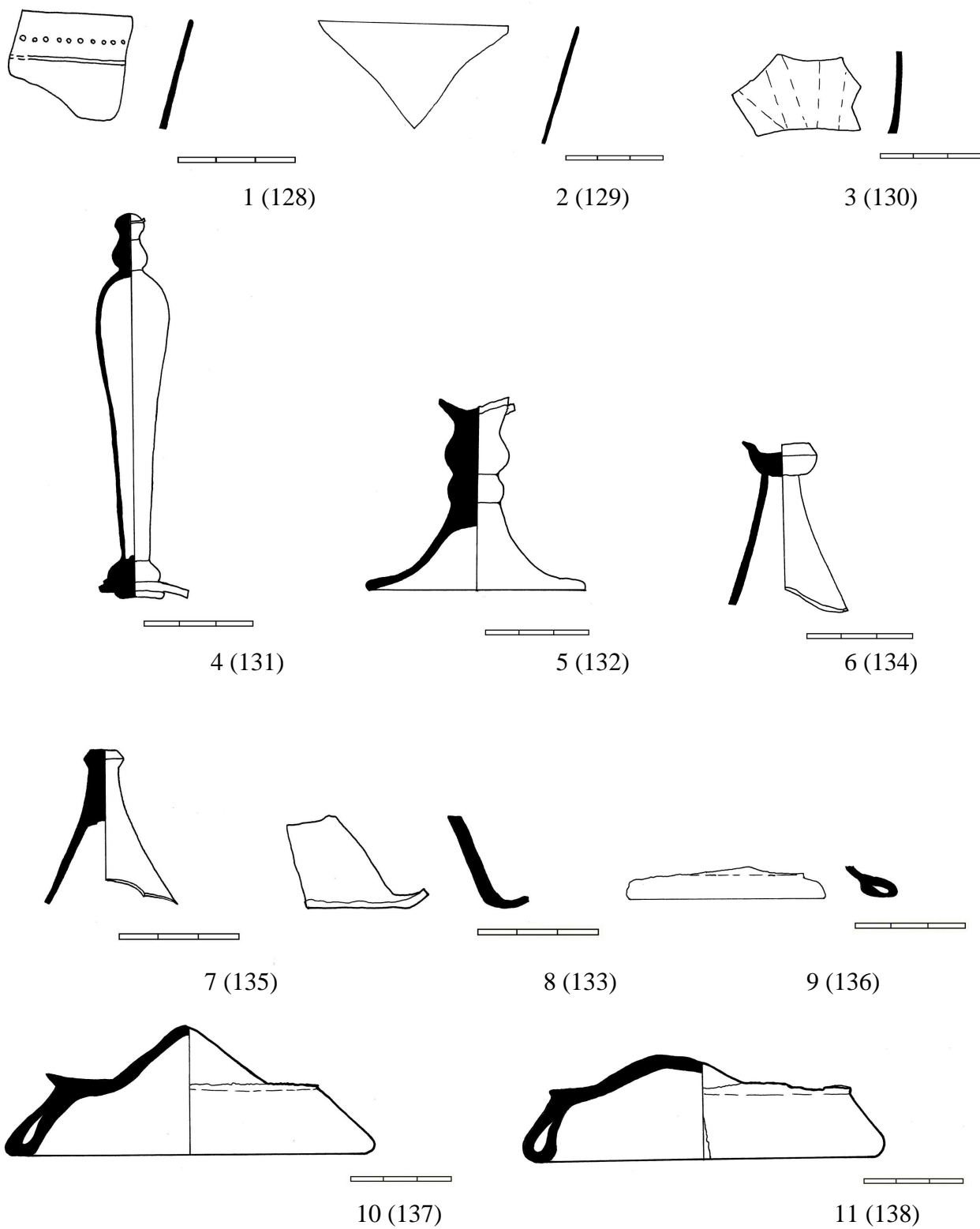

1-11 – skleněné nálezy

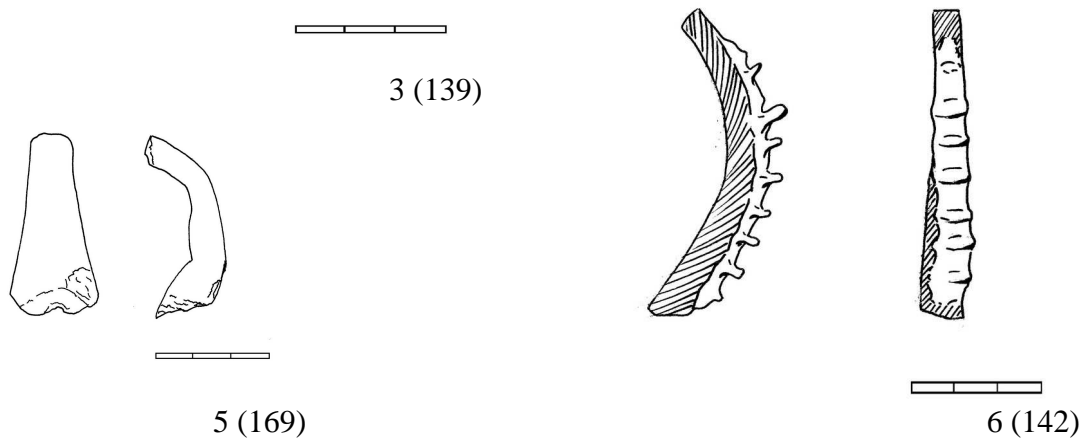
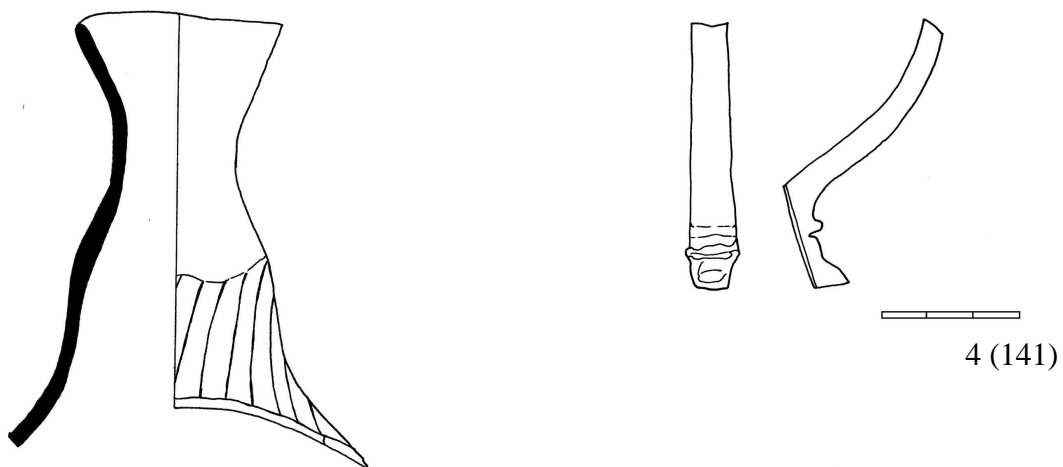
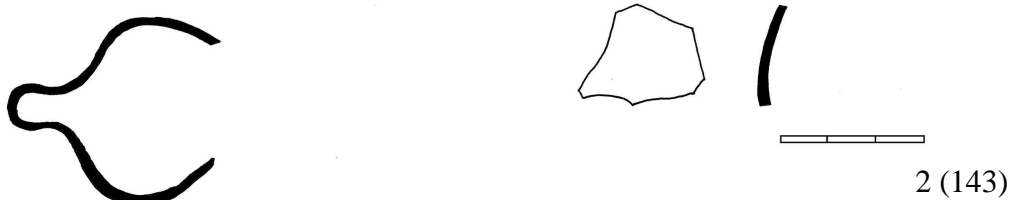
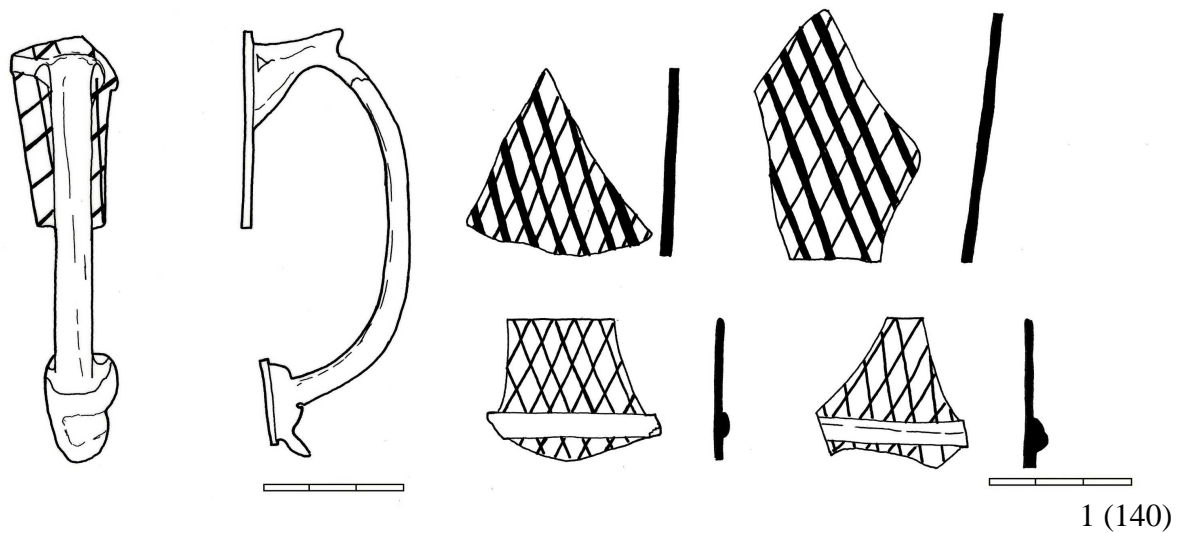

1-6 – skleněné nálezy

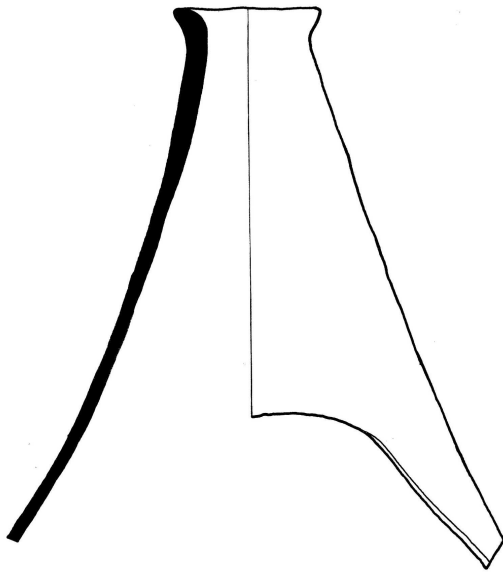

1 (144)

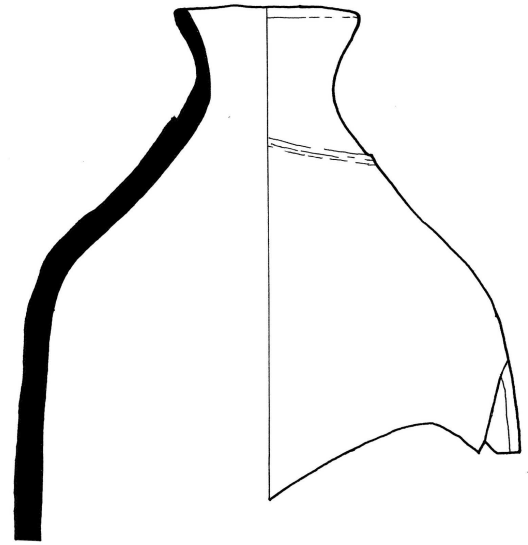

2 (145)

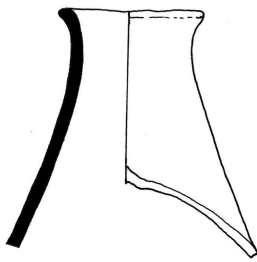

3 (146)

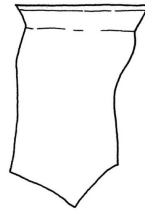

4 (147)

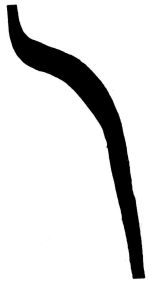
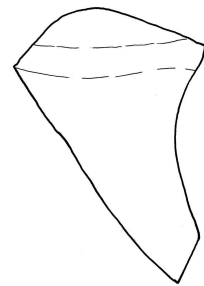

5 (148)

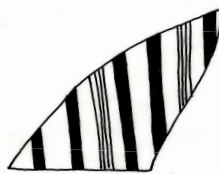

6 (149)



7 (150)

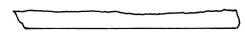

8 (152)



9 (153)

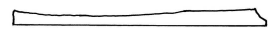

10 (154)

1-10 – skleněné nálezy

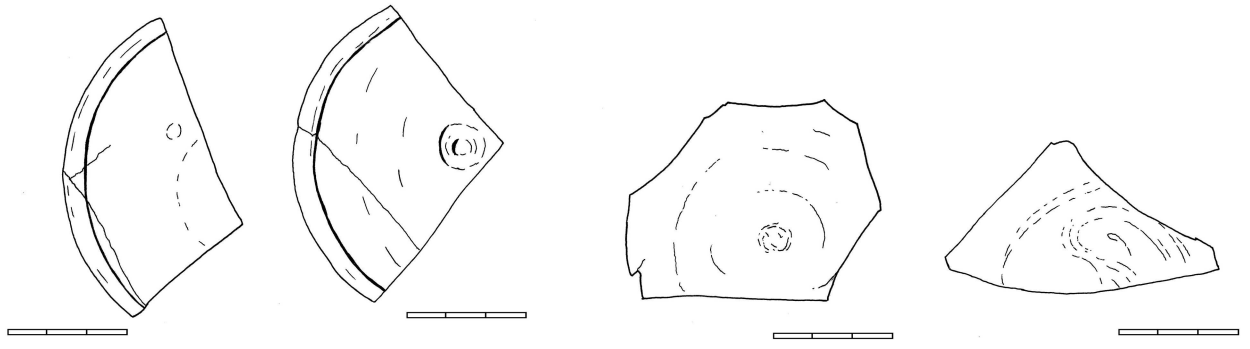

1 (155)

2 (156)

3 (157)

4 (158)

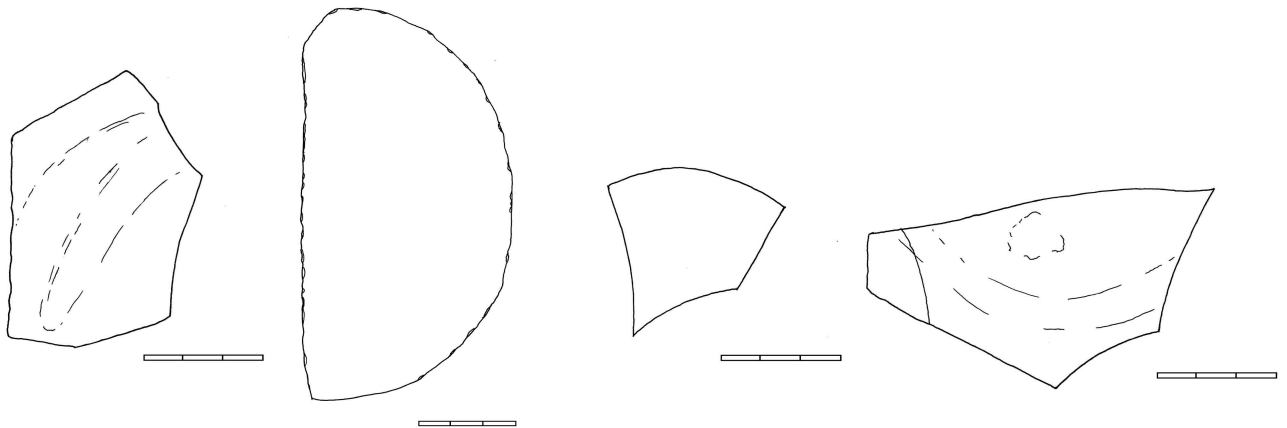

5 (159)

6 (160)

7 (161)

8 (162)

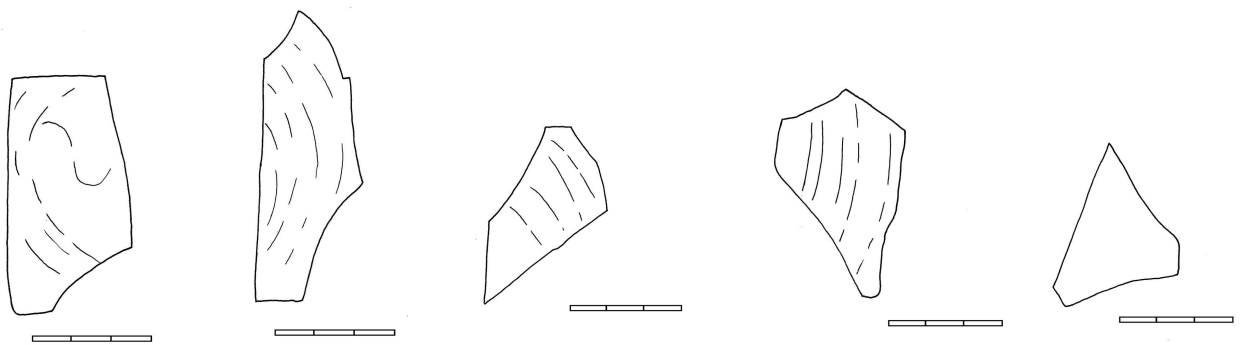

9 (163)

10 (164)

11 (165)

12 (166)

13 (167)

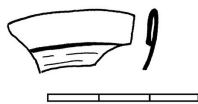

14 (168)

1-14 – skleněné nálezy

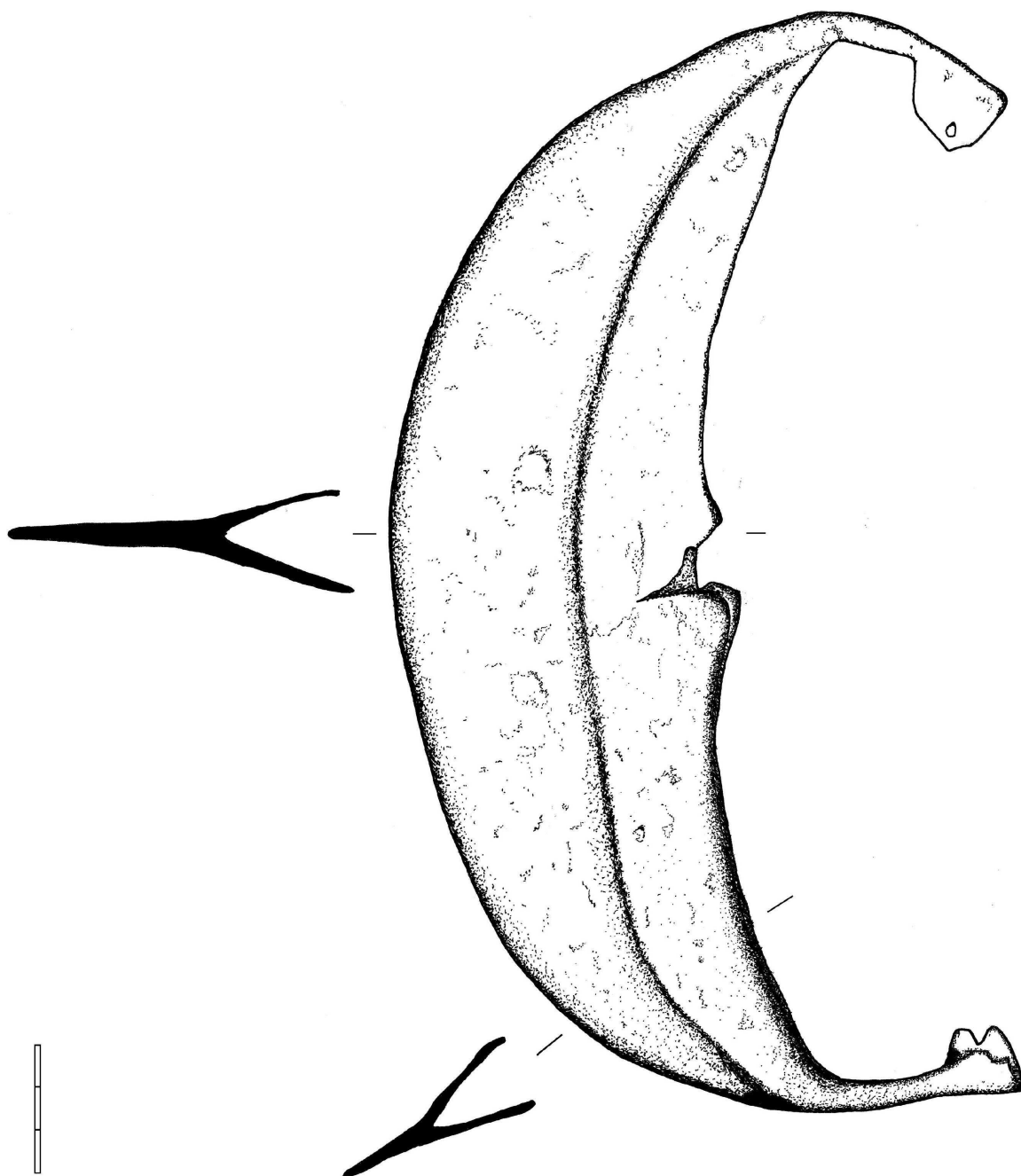

1 (185)

1 – kování rýče

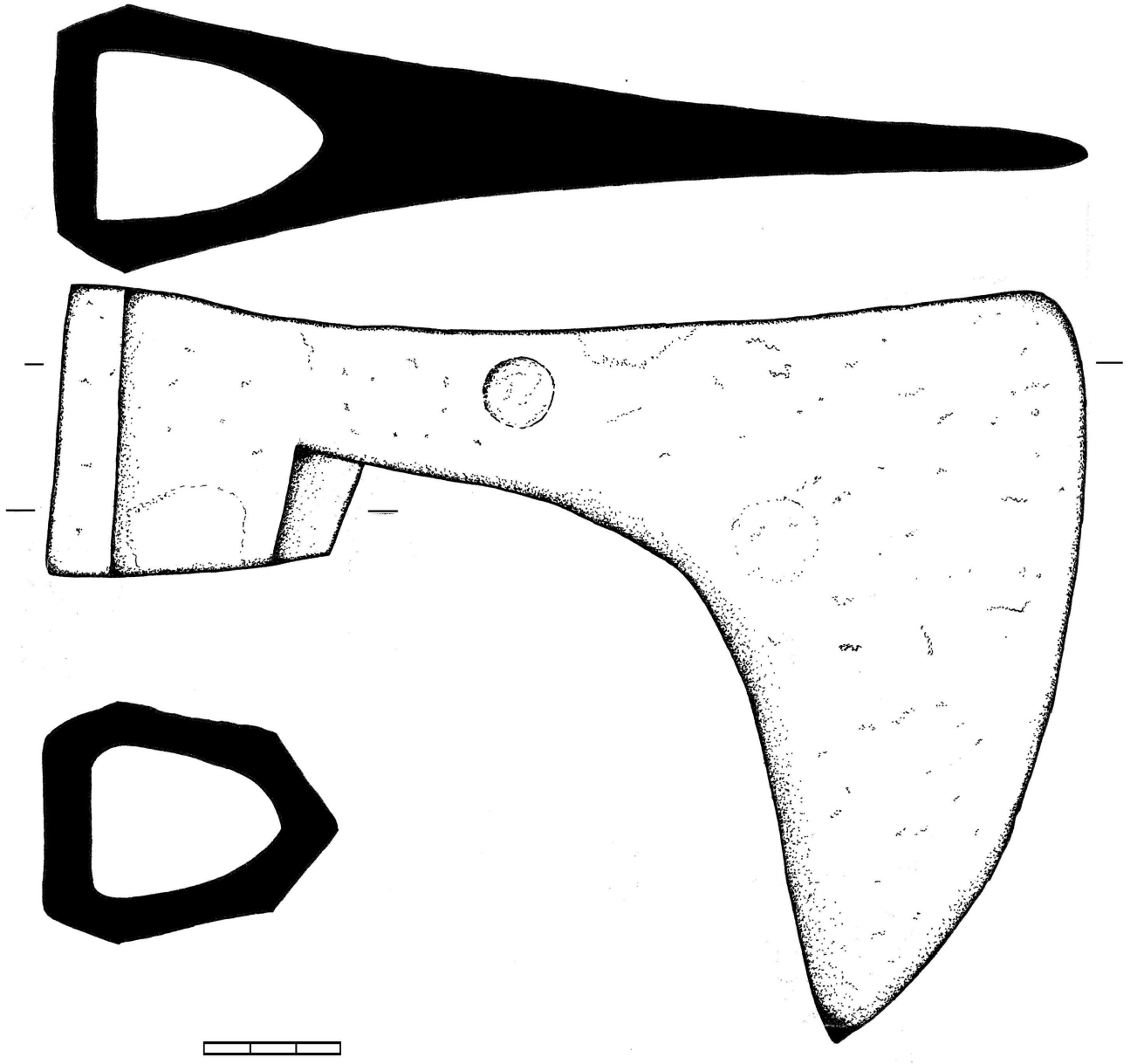

1 (186)

1 – sekera

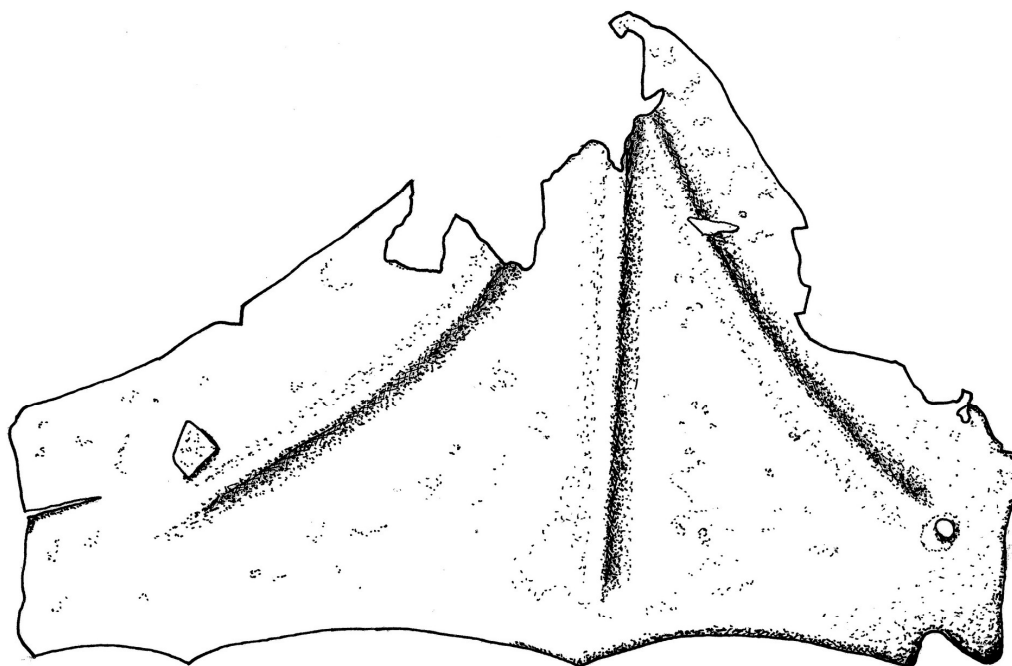

1 (188)

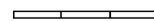
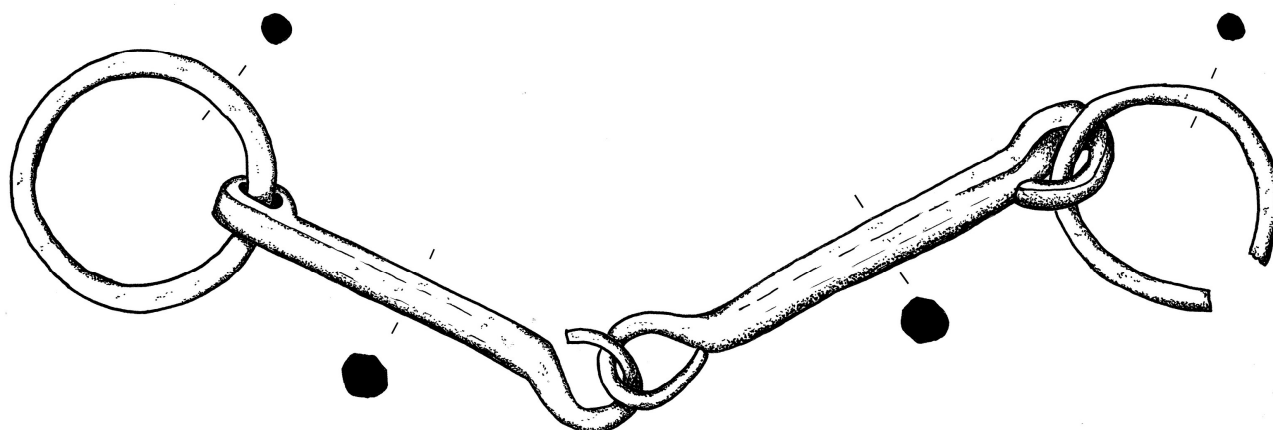

2 (189)

1-2 – kovové nálezy

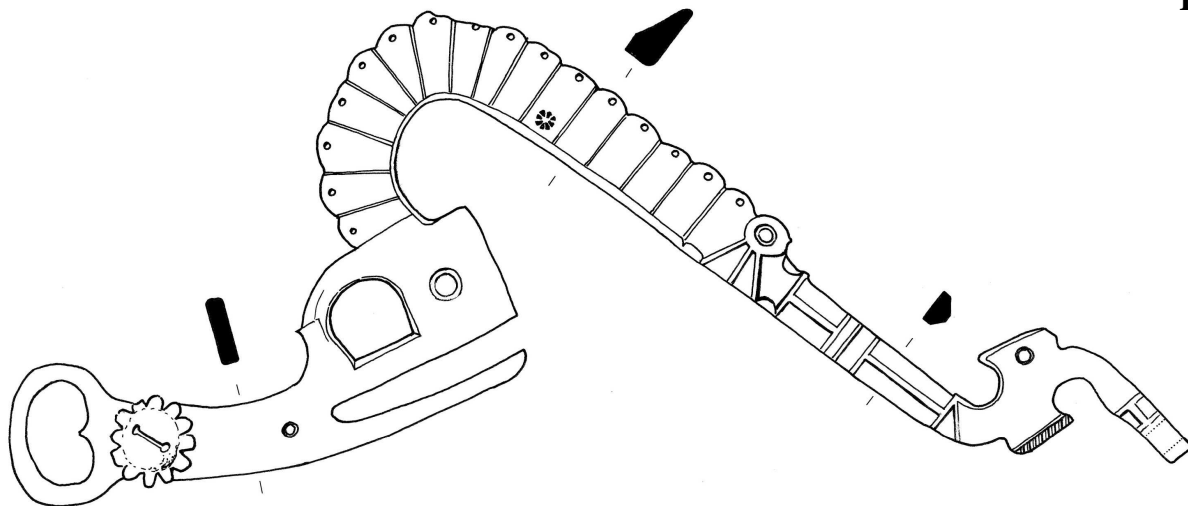

1 (190)

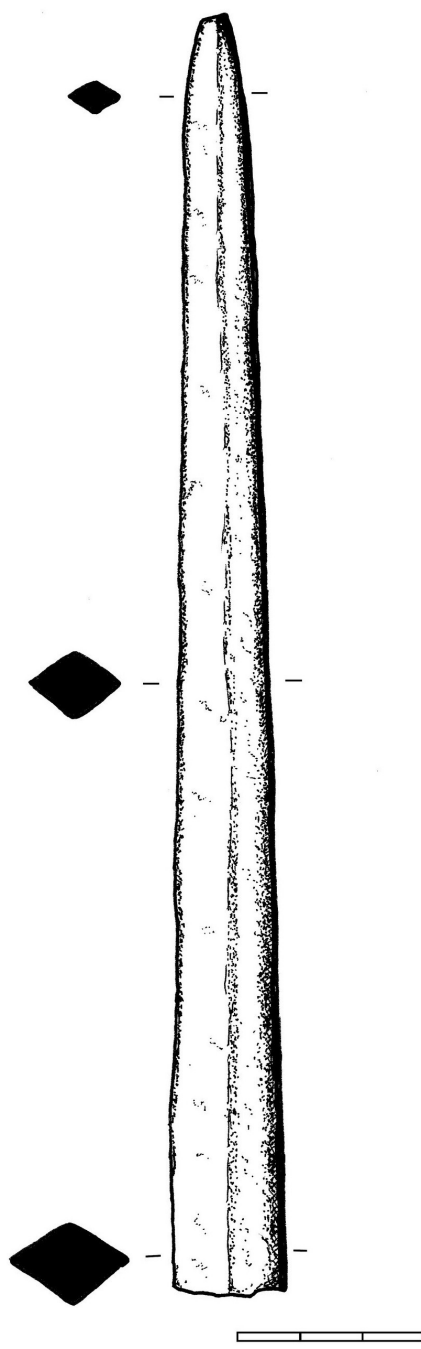

2 (187)

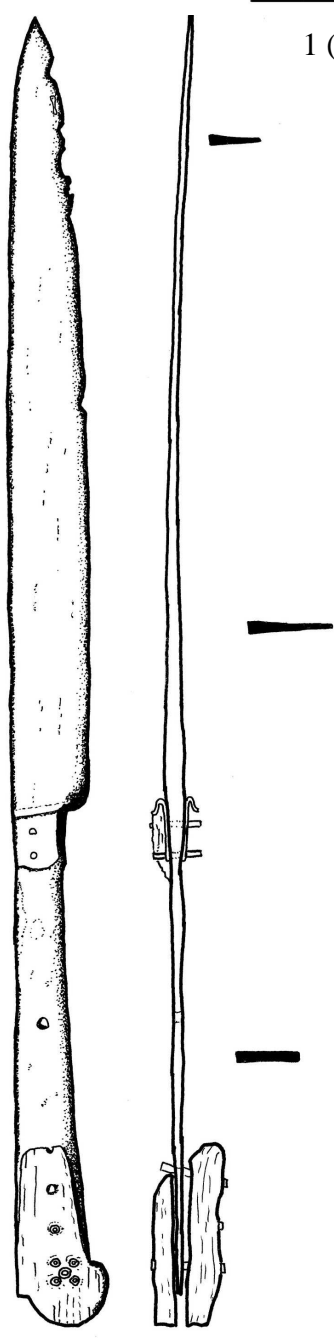

3 (191)

1-3 – kovové nálezy

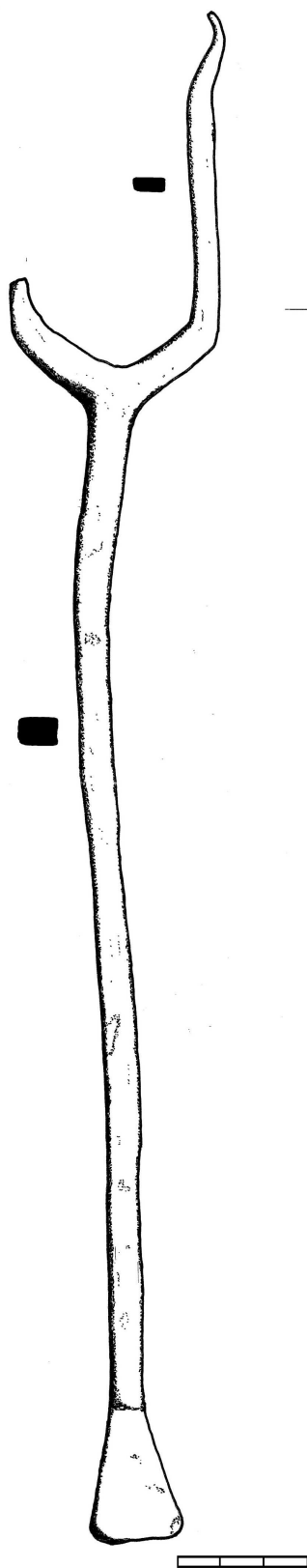

1 (196)

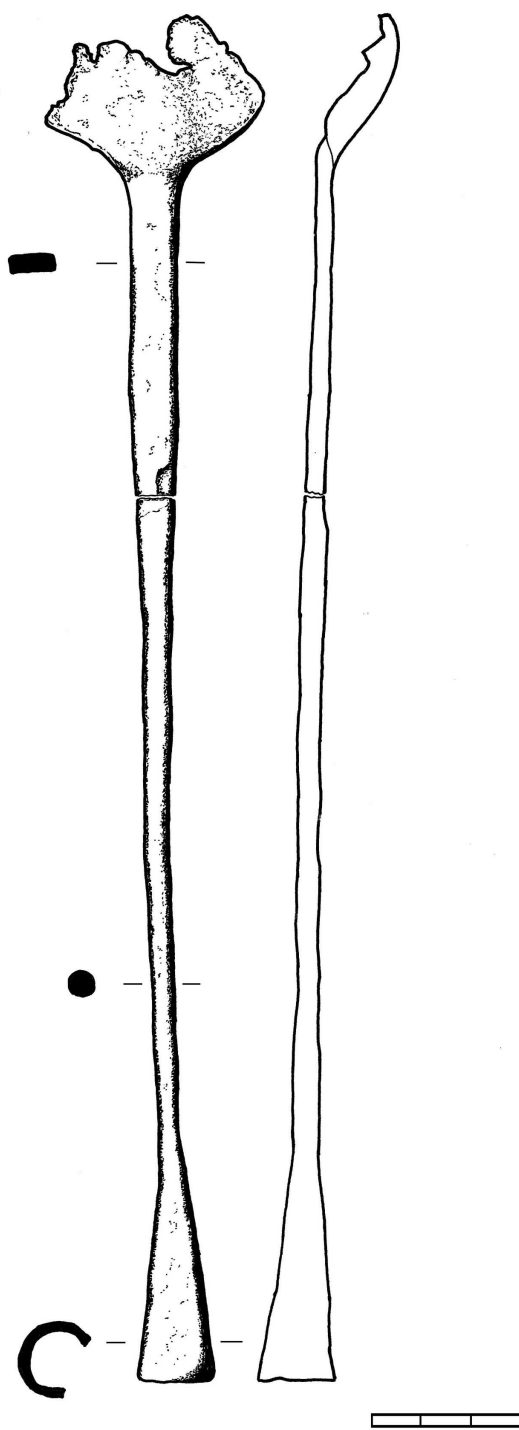

2 (195)

1-2 – kovové nálezy

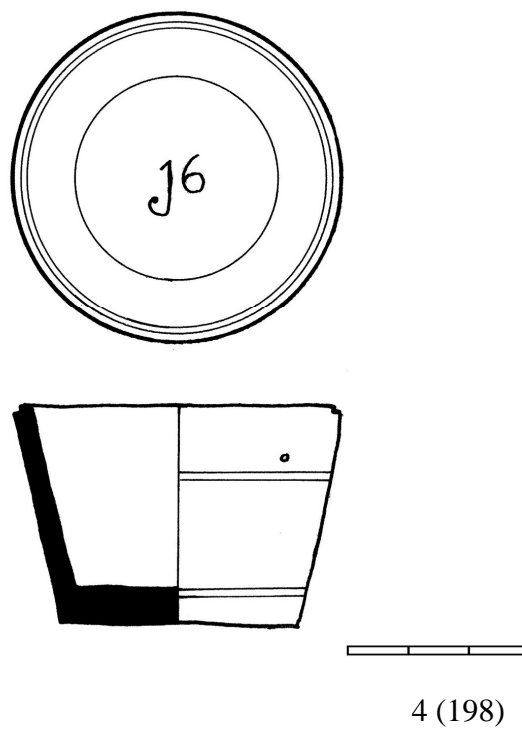
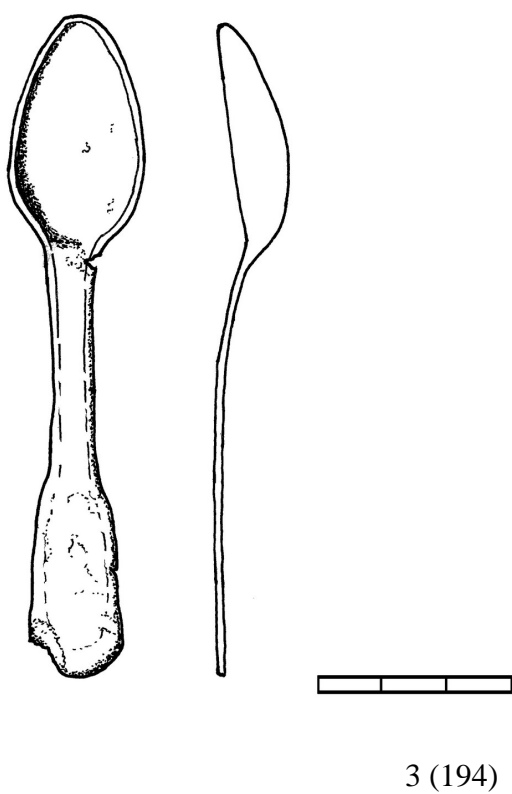
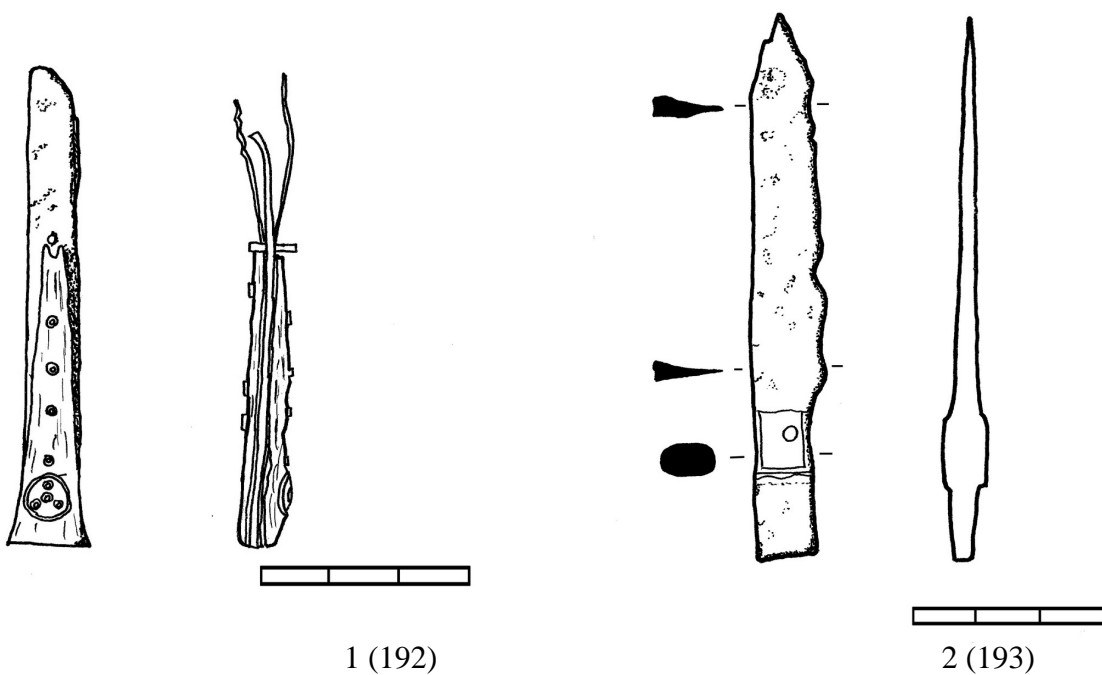

1-4 – kovové nálezy

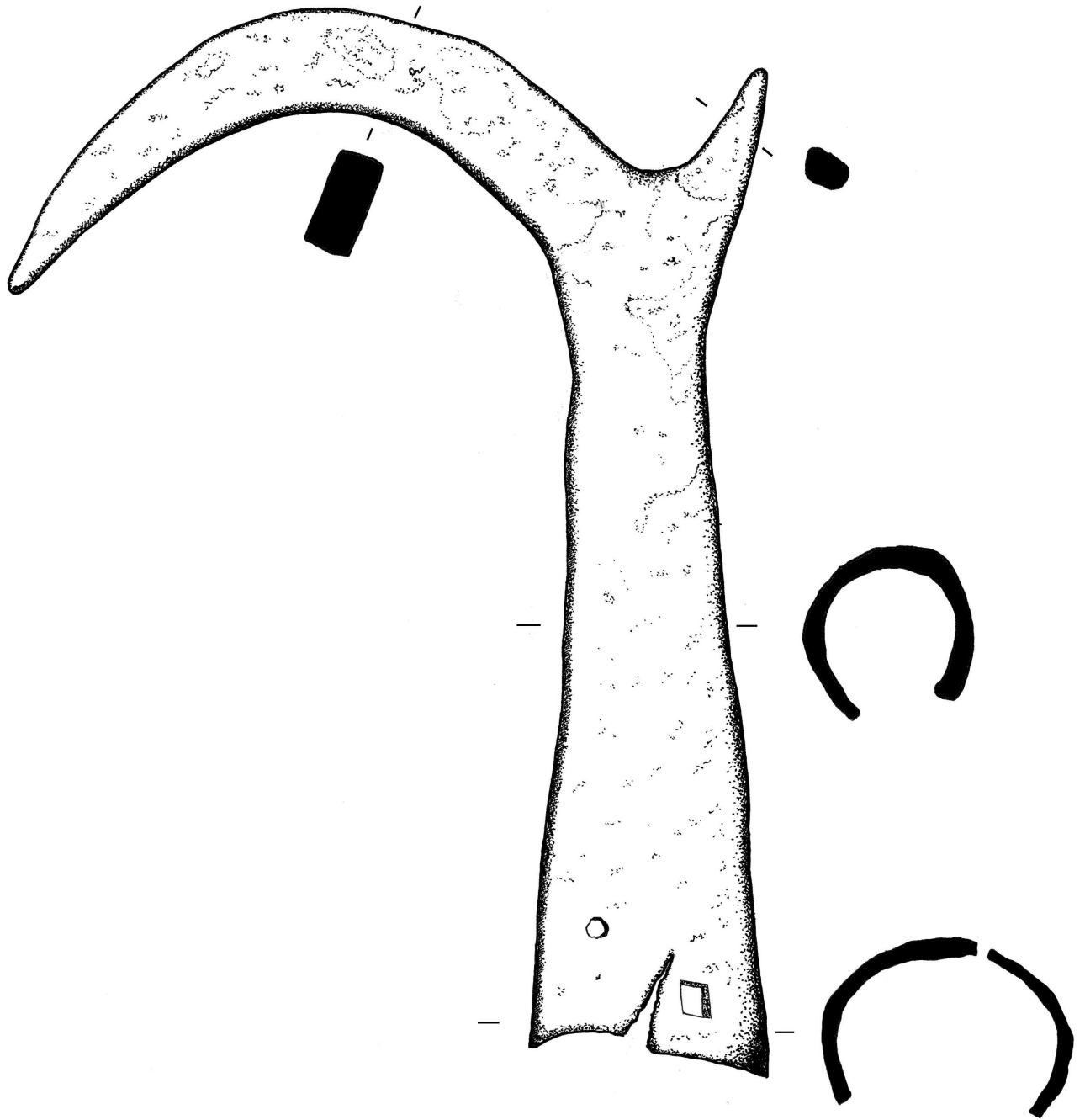

1 (197)

1 - Hák

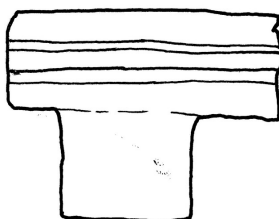
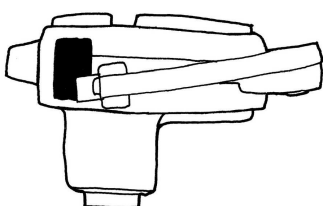
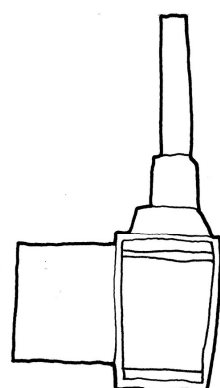
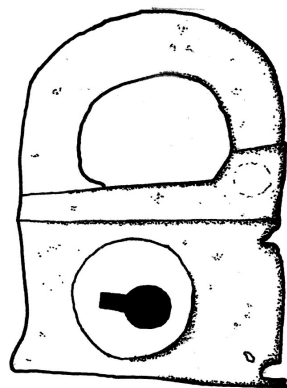
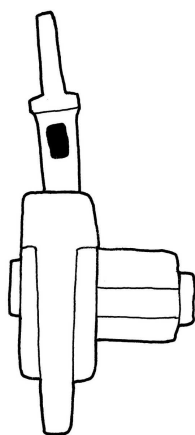
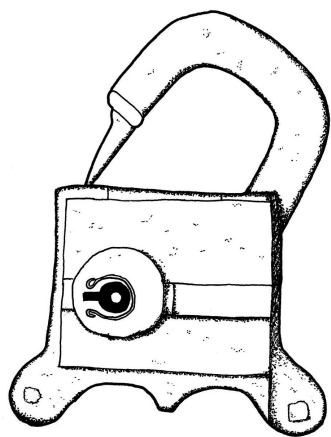

1 (199)

2 (202)

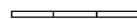
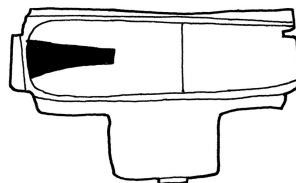
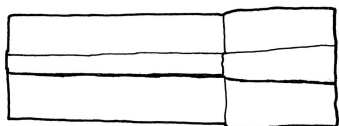
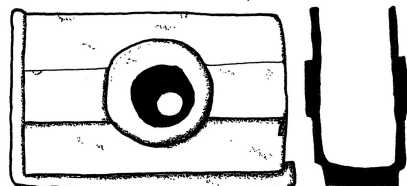
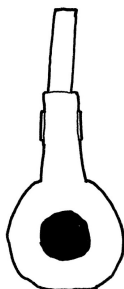
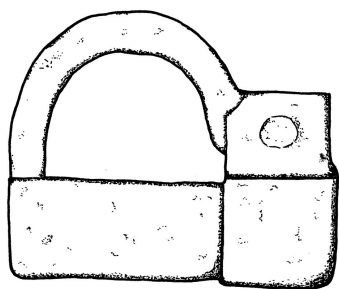

3 (200)

4 (201)

1-4 – kovové nálezy

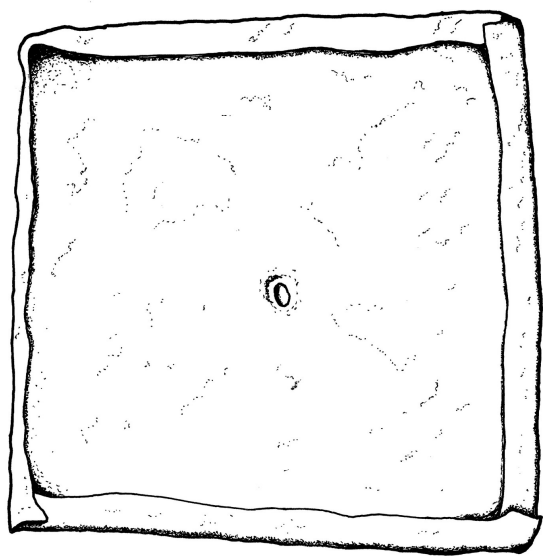

1 (203)

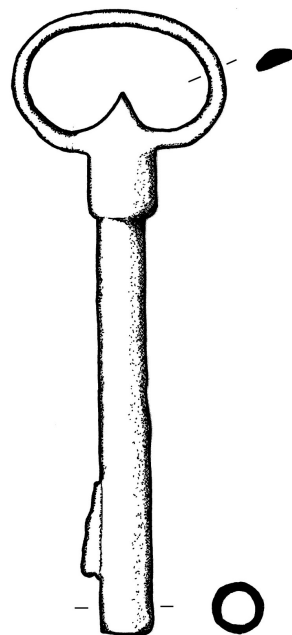

2 (205)

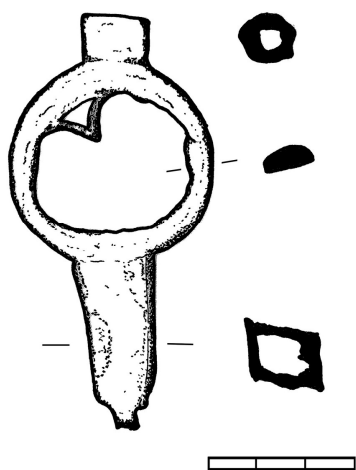

3 (204)

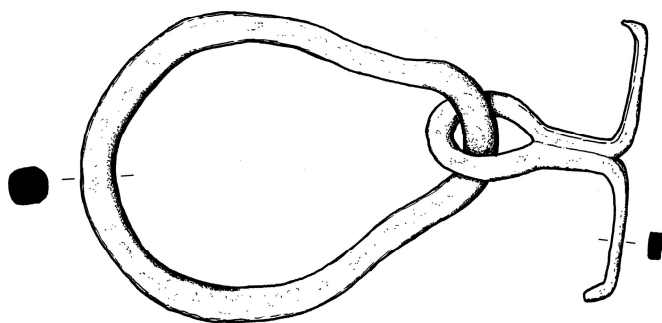

4 (206)

1-4 – kovové nálezy

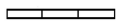
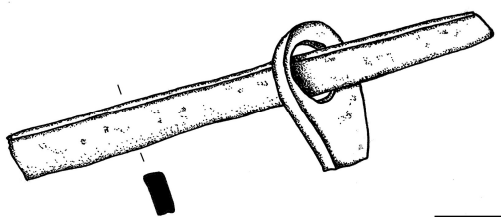

1 (207)

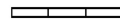

2 (210)

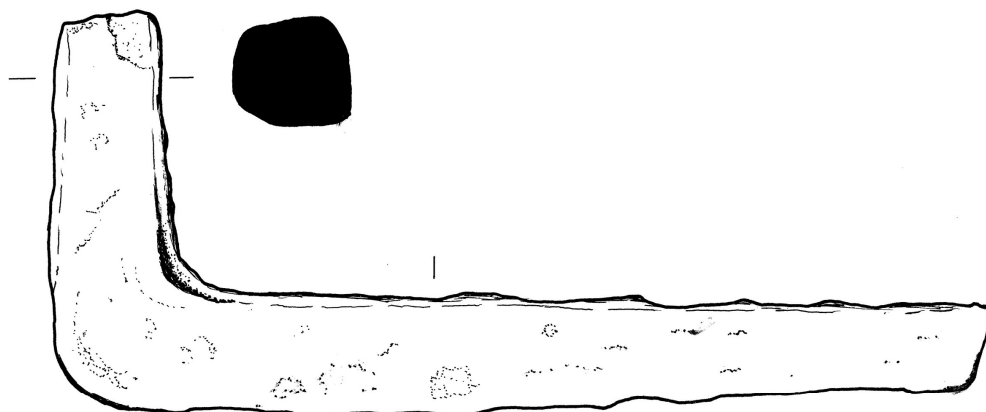

3 (208)

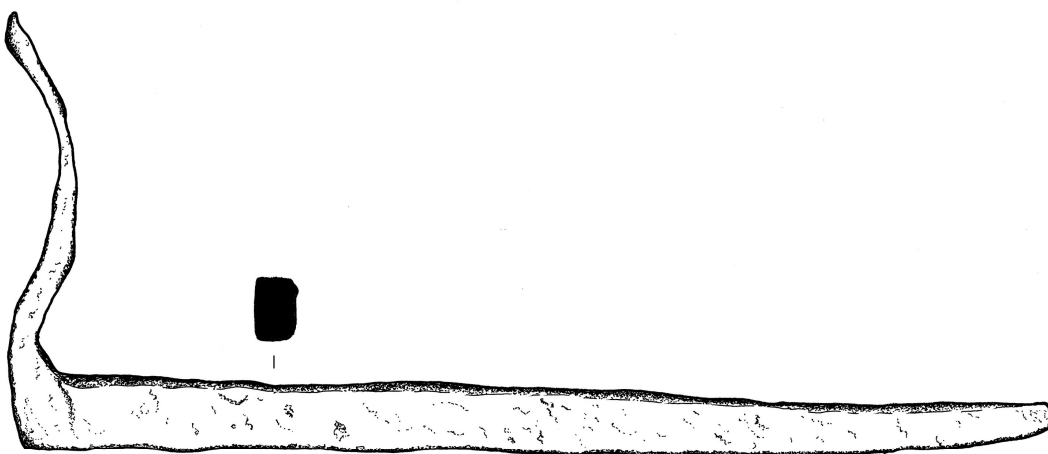
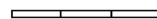

4 (209)

1-4 – kovové nálezy



1 – usňové nálezy

1 (212)



1 (213)



1 (214)

1-2 – kostěné nálezy



1 (215)

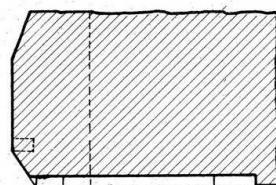
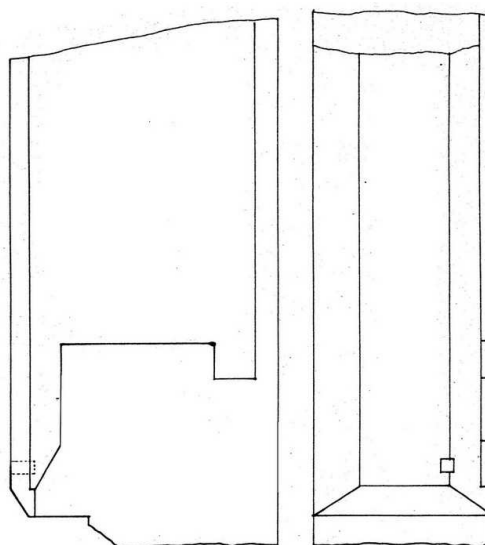

2 (217)

- 1 – pilota
- 2 – kamenný architektonický článek (nedochováno)

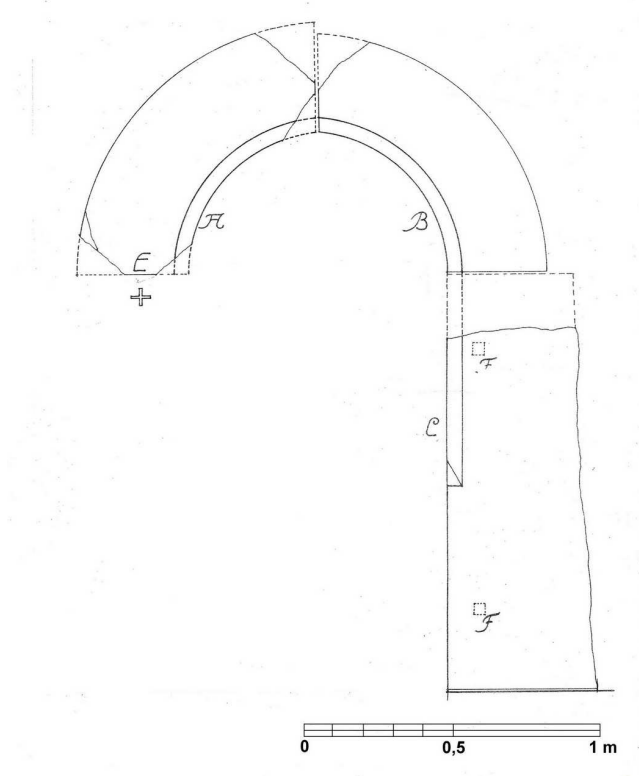

1 (216)



2



3

1 – Portál (nedochováno)

2 – Džbán (kat. č. 1) – příklad redukčně pálené keramiky

3 – Džbán (kat. č. 3) – příklad redukčně pálené keramiky



1



2



3



4

- 1 – Hrniec (kat. č. 5)
- 2 – Hrniec (kat. č. 6)
- 3 – Hrniec dvojuchý (kat. č. 7)
- 4 – Pohár (kat. č. 10)



1



2



3



4

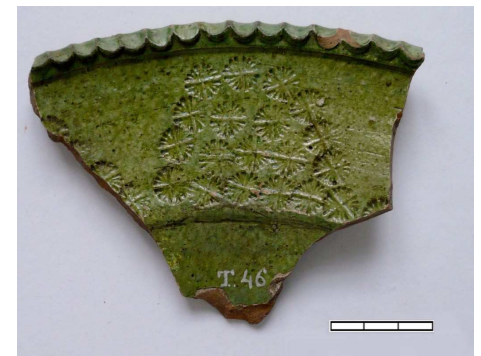

5



6

- 1 – příklad podsýpaného dna, s viditelným napojením dna a těla nádoby (kat. č. 5)
 2 – příklad dna se zřetelnými stopami po odříznutí (kat. č. 4)
 3 – část těla džbánu (kat. č. 65)
 4 – talíř (kat. č. 19)
 5 – zlomek talíře (kat. č. 21)
 6 – zlomky talíře (kat. č. 22)



1



2



3



4



5



6

- 1 – spodní část číše (kat. č. 119)
- 2 – okraj číše (kat. č. 118)
- 3 – zlomek číše? (kat. č. 122)
- 4 – zlomek číše (kat. č. 120)
- 5 – zlomky číše? (kat. č. 123)
- 6 – zlomky lahve (kat. č. 149)



1



2



3



4



5

- 1 – zlomky džbánu? (kat. č. 140)
- 2 – vrchní část konvice (kat. č. 139)
- 3 – pákové udilo (kat. č. 190)
- 4 – detail výzdoby rukojeti nože s dochovaným dřevem (kat. č. 192)
- 5 – detail výzdoby rukojeti nože s dochovanou parohovinou (kat. č. 191)

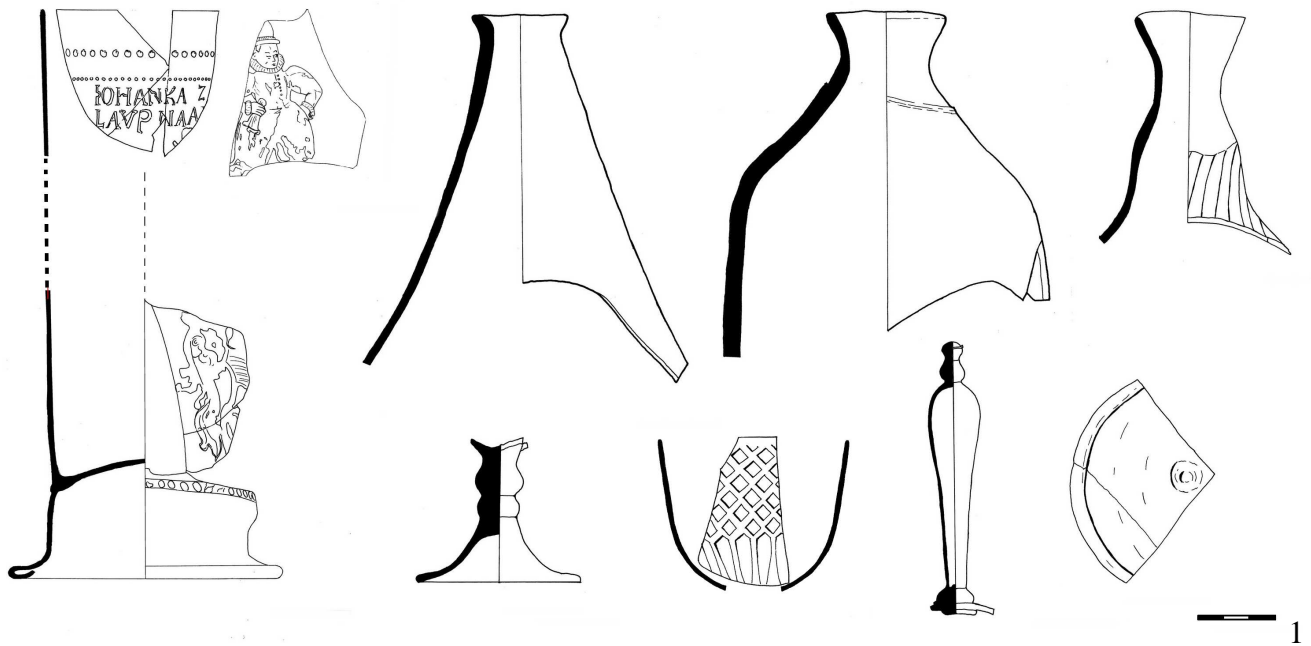

2

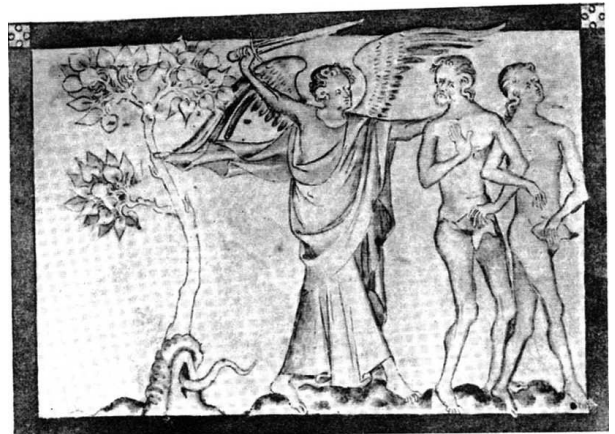

3

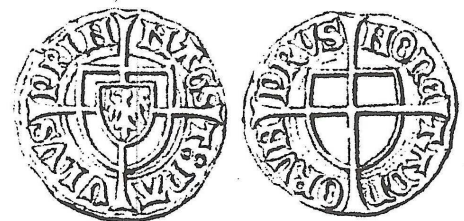

4

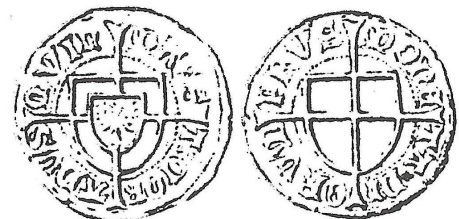

5

- 1 – zastoupení hlavních tvarů skleněných nálezů
 2 – motiv Vyhnání z Bible krále Václava IV. (podle Hazlbauer 1991, 177)
 3 – motiv Vyhnání z Queen Mary's Psalter (podle Urbánková – Stejskal 1975, 100)
 4 – mince ražená komturem Pavlem von Russdorf (1422-1441), Gdaňsk (podle Kopicki 1975, 167)
 5 – mince ražená komturem Konrádem von Erlichhausen (1441-1449), Gdaňsk, (podle Kopicki 1975, 167)

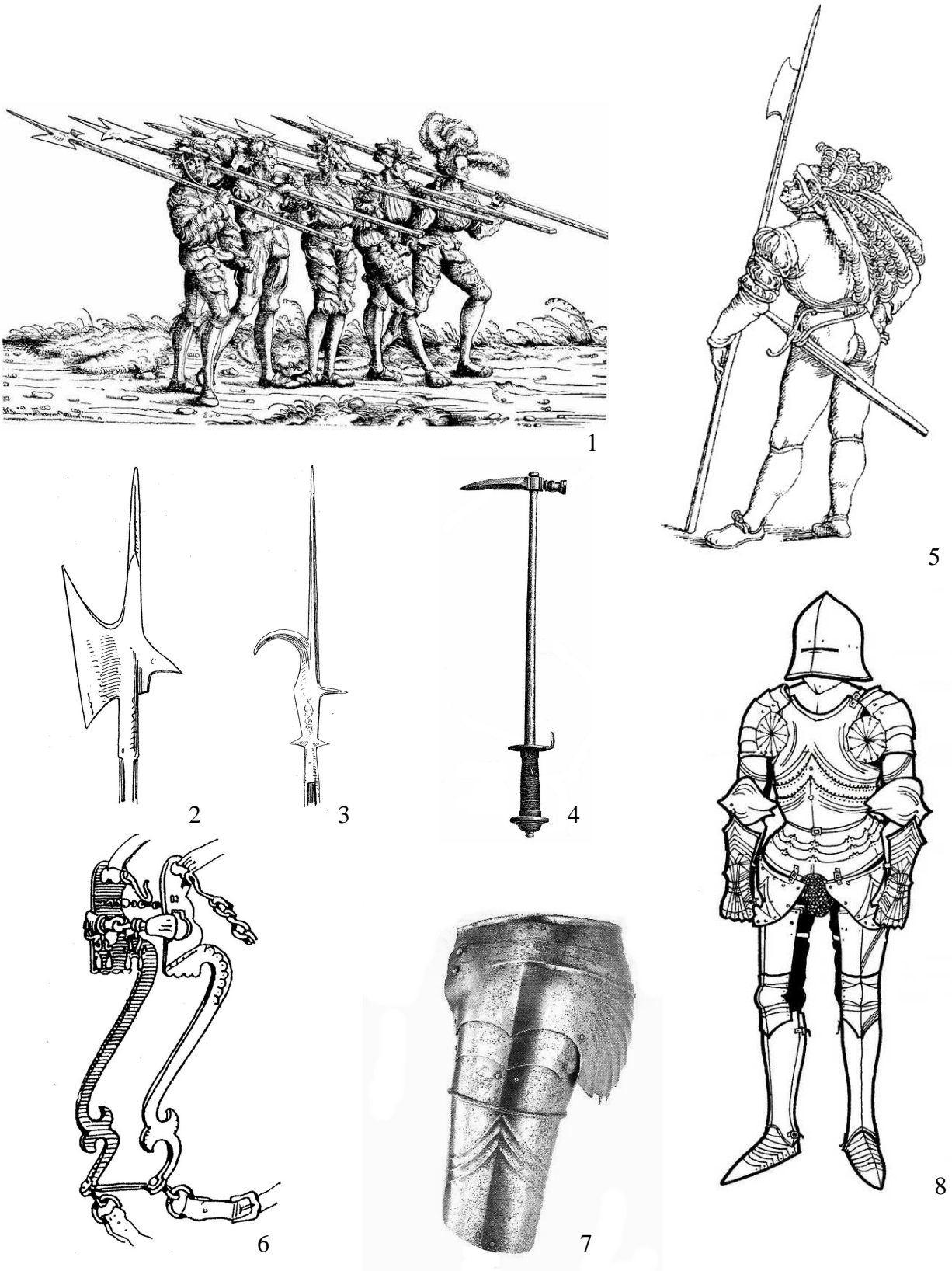

- 1 – skupina halapartníků první dvacetiletí 16.století (podle Klučina 2004, 534)
 2 – halapartna doby Maxmiliána I. okolo roku 1500 (Boeheim 1890, 332).
 3 – halapartna, konec 15. století (podle (Boeheim 1890, 40)
 4 – příklad bojového kladiva (podle Klučina 2004, 43)
 5 – Pěší halapartník naobrazení okolo r. 1505 (podle Klučina 2004, 539)
 6 – Pákové udidlo z konce 15. století (podle Boeheim 1890, 194)
 7 – nárameník pozdně gotické zbroje z doby kolem roku 1480, Německo (podle Hrbatý 2006, 63)
 8 – kresba pozdně gotické zbroje podle originálu z roku 1480, Německo (podle Hrbatý 2006, 59)



1



2



3

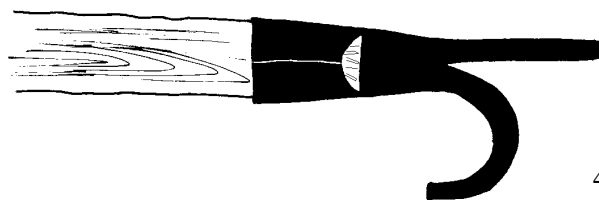

4

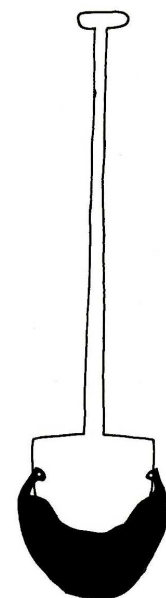

5

- 1 – detail obrazu Quentina Massyse z roku 1514 – na stole jsou vidět lotová závaží (podle Krajíc 2006, 310)
- 2 – Noe při práci na vinici používá rýč s kovovou násadou – Velislavova Bible (podle Matějček 1926, fol.10)
- 3 – kompletní rozložená sada lotových závaží
- 4 – Hák, Soubor lidových staveb Vysočina, skanzen Veselý kopec
- 5 – rýč s kovovou násadou, Soubor lidových staveb východní Hané Rymice u Holešova