

9. OBRAZOVÁ PŘÍLOHA

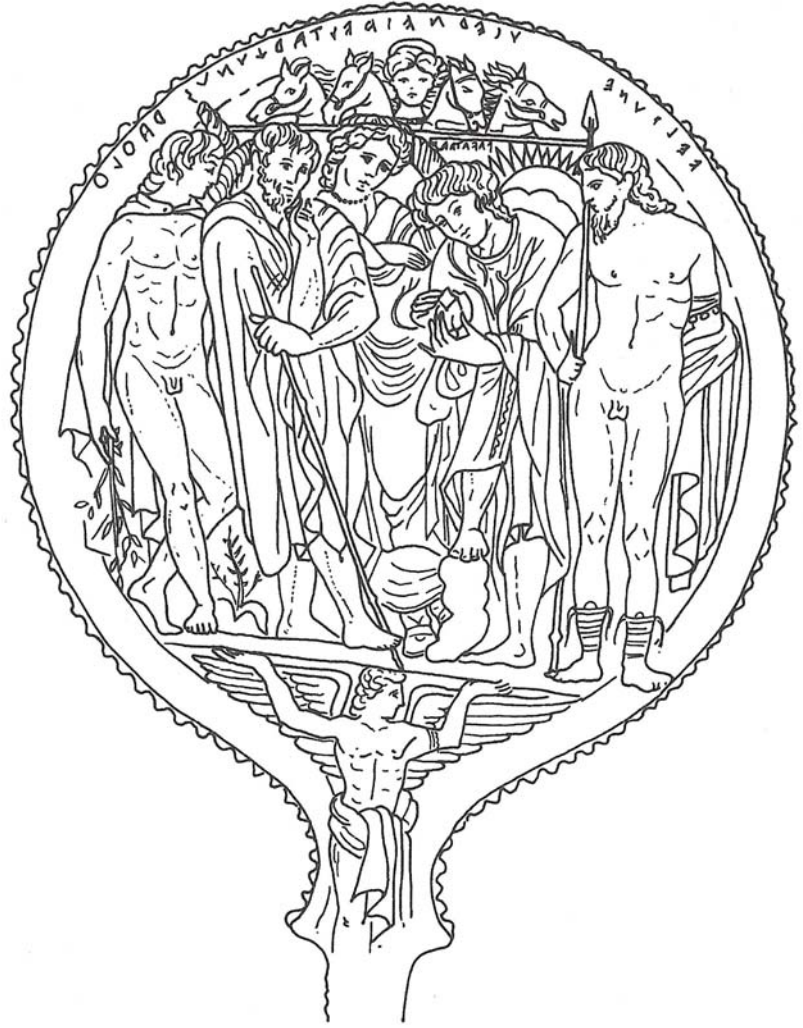

1

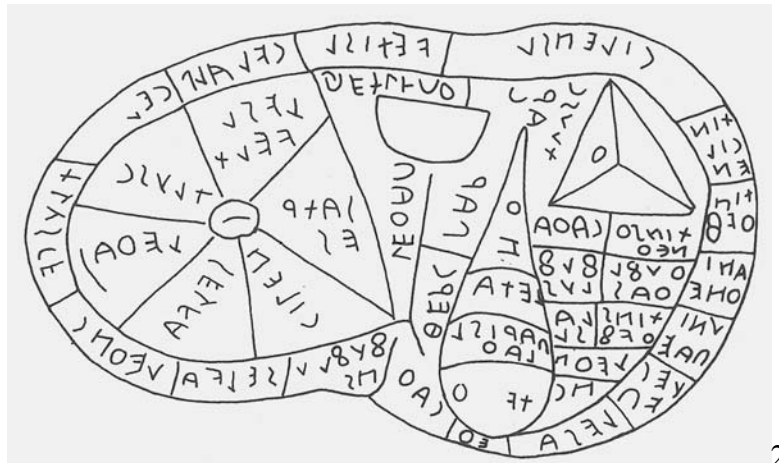

2

1. Etruské zrcadlo s haruspiky (Tagés učí Tarchóna věštění), 3. století, PALLOTINO 1984, Tav. XXIX, BARKER-RASMUSSEN, s. 222, obr. 86, Archeologické muzeum Florencie.

2. Játra z Piacenzy, 3. – 2. století př. Kr., PALLOTINO 1984, Tav. XXX, RICHARDSON 1986, s. 222, obr. VI-13a, b, BARKER-RASMUSSEN, s. 223, obr. 87, Museo Civico Piacenza.

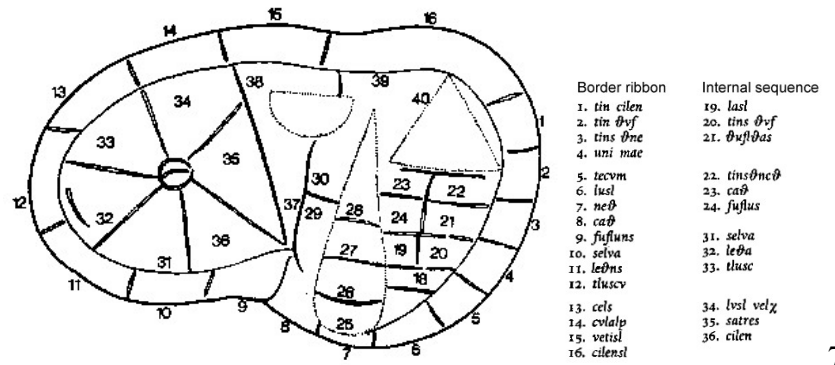

7

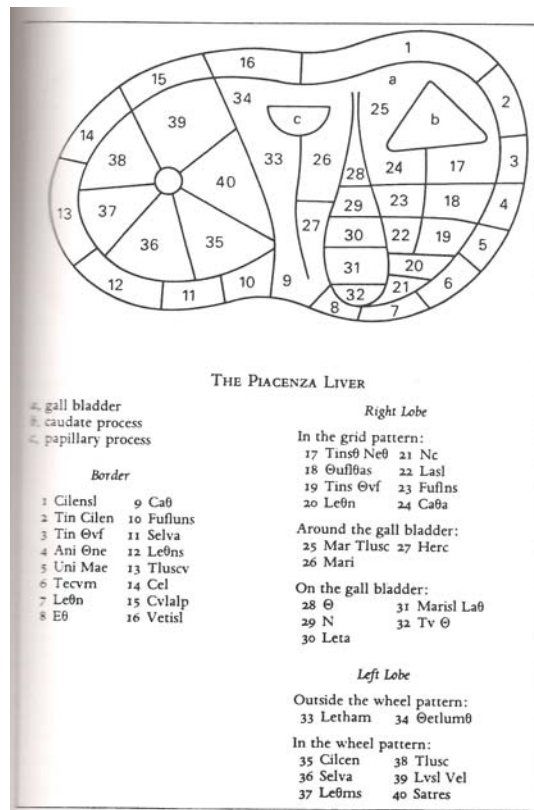

8

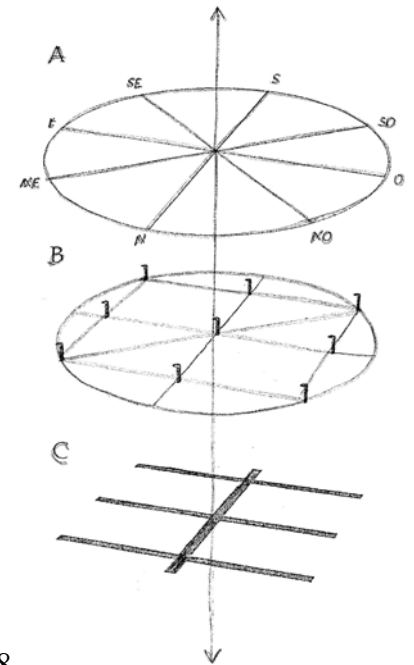

9

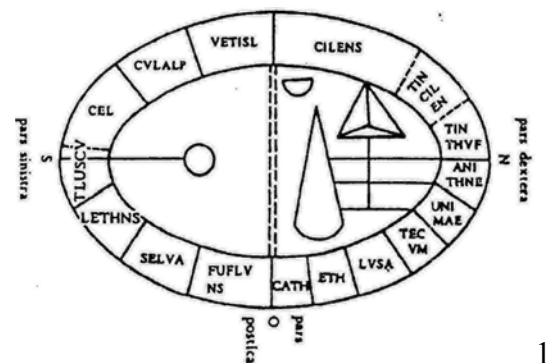

10

7. Játra z Piacenzy, Museo Civico Piacenza.

8. Játra z Piacenzy, RICHARDSON 1986, s. 223, obr. VII-13, Museo Civico Piacenza.

9. Vertikální rozdělení *templa* na tři vrstvy: *templum* nebeské, augurální a osy městské sítě v Marzabottu, GOTTARELLI 2003, s. 152, obr. 1a.

10. Játra z Piacenzy, MUSIL 2000, s. 52, obr. 1.



11

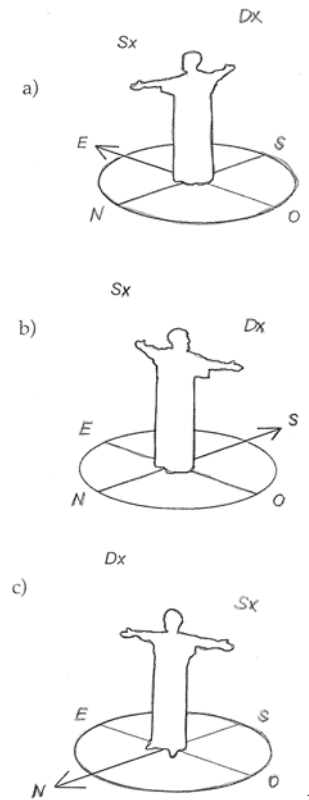

12

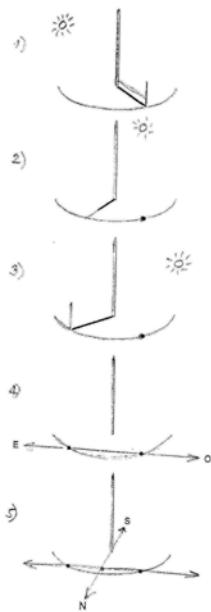

13

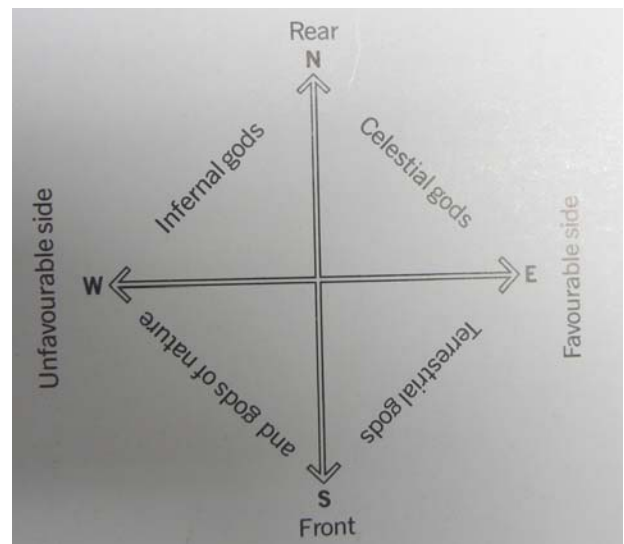

14

11. Bronzová soška veštky v charakteristickém oděvu, PALLOTINO 1984, Tav. XXXI, Vatikán, Museo Etrusco Gregoriano.

12. Systém rituální orientace – kněz, GOTTARELLI 2003, s. 161, obr. 7.

13. Vymezování světových stran pomocí grómy, GOTTARELLI 2003, s. 157, obr. 4.

14. Nebeské oblasti, CRISTOFANI, s. 92.

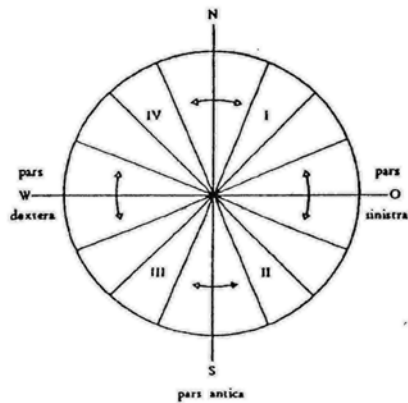

15

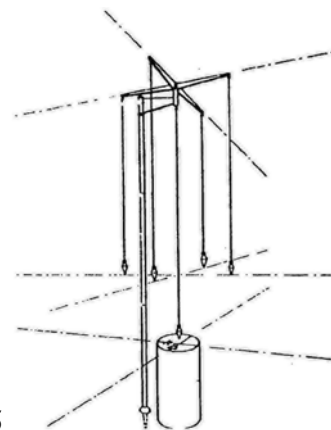

16



17

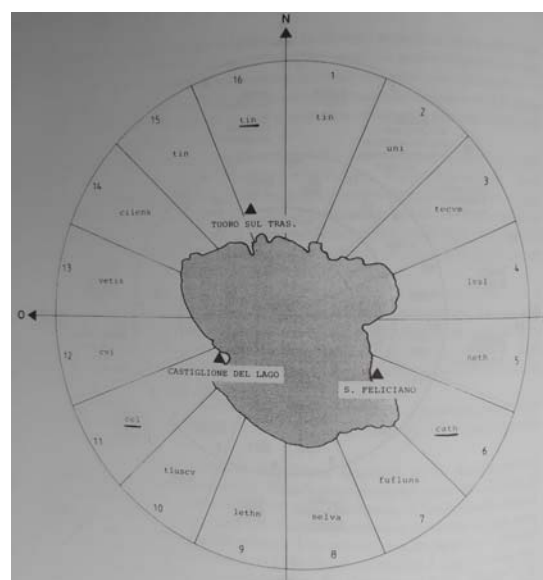

18

15. Prostor podle Plinia, *Naturalis historia* II 143, MUSIL 2000, s. 52, obr. 2.

16. Vyměřování základní sítě cest pomocí grómy, MUSIL 2000, s. 52, obr. 3.

17. Liber linteus, mumie ze Záhřebu, PALLOTINO 1984, Tav. LXXVIII, Museo Nazionale Záhřeb.

18. Svatyně na březích Trasimenského jezera a nebeské oblasti dle Etrusků, PRAYON 1997, s. 366, obr. 7.

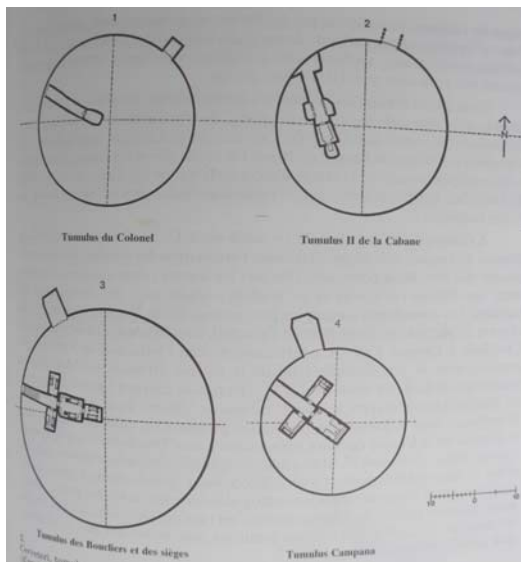

19

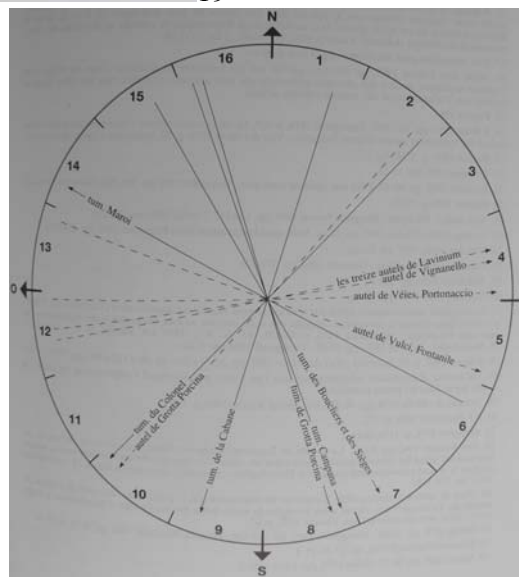

20

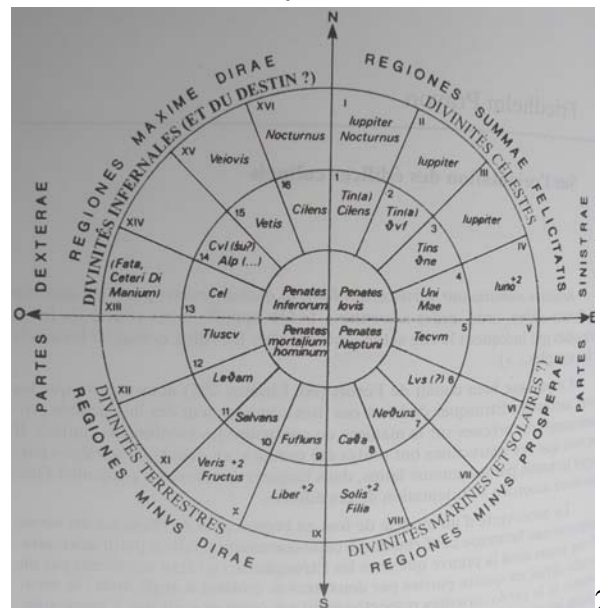

21

19. Cerveteri, monumentální tumuly s přístupovou rampou, PRAYON 1997, s. 359, obr. 2.

20. Orientace oltářů a ramp tumulů v etrusko-italickém světě, PRAYON 1997, s. 369, obr. 8.

21. Nebeské oblasti u Etrusků, PRAYON 1997, s. 358, obr. 1, podle Maggianiho/Simona 1984, s. 139.

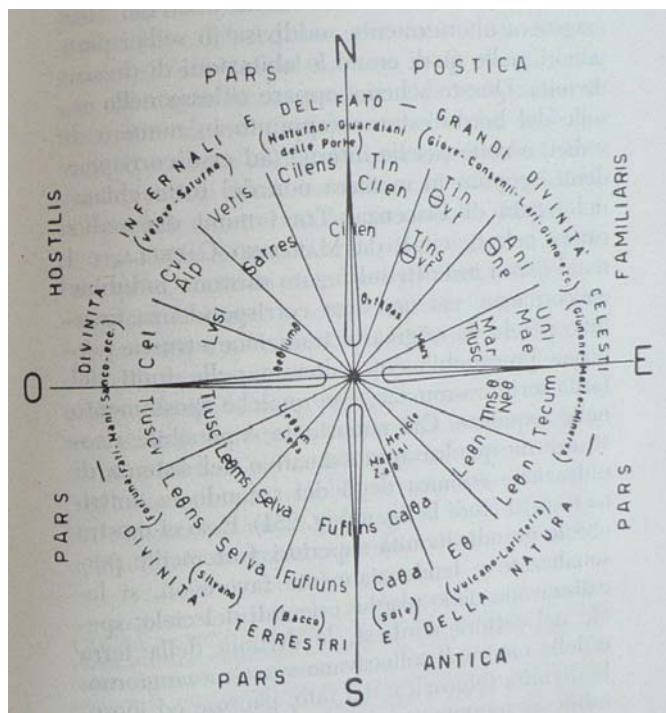

22

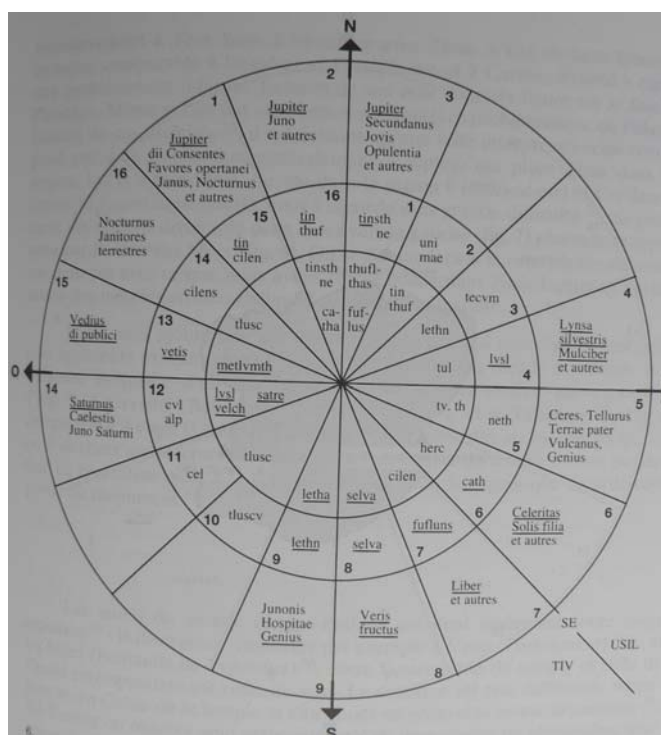

23

22. Massimo Pallottino: schéma dle Martiana Capelly (vnější kruh) a jater z Piacenzy (etruská jména ve vnitřních kruzích a v šestnácti sektorech), PALLOTINO 1973, s. 251.

23. Nebeské oblasti u Etrusků, PRAYON 1997, s. 365, obr. 6, podle Van der Meera 1987, s. 24, obr. 14.

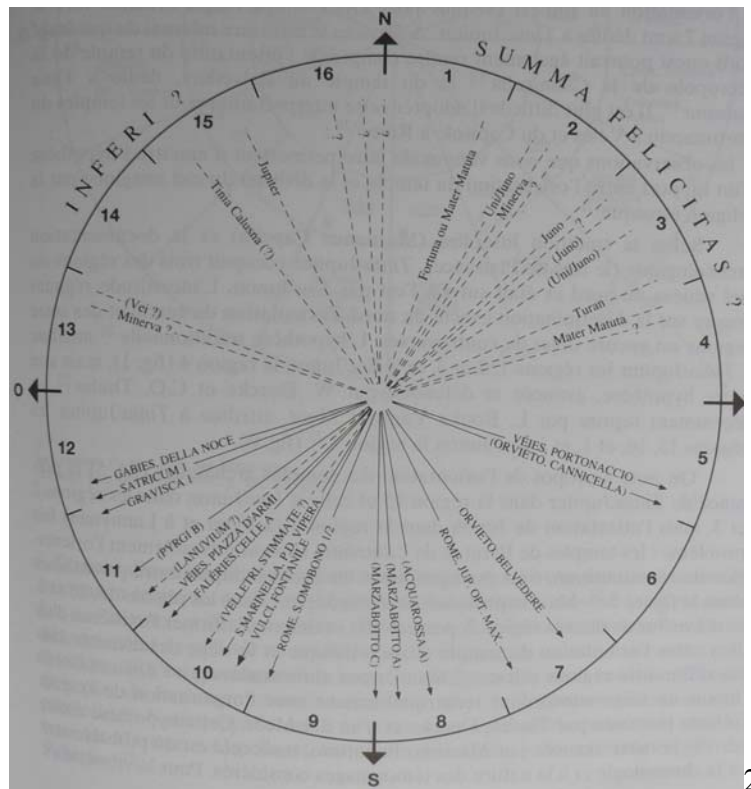

24

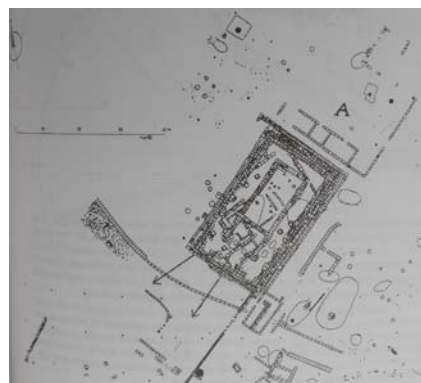

25



26

24. Orientace etrusko-italických chrámů v archaické epoše (jména božstev uctívaných v těchto chrámech jsou vyznačena na konci každé osy), PRAYON 1997, s. 363, obr. 5.

25. Satricum, akropole, orientace chrámu Mater Matuta během různých fází, budova A, PRAYON 1997, s. 361, obr. 3.

26. Portonaccio, Veje, orientace chrámu a oltáře, PRAYON 1997, s. 362, obr. 4.



27

28



29



30

28. Model chrámu v Alatri, Museum di Villa Giulia Řím, BUONAMICI-MODONA 1926, obr. 6.
29. – 30. Model chrámu v Alatri, Museum di Villa Giulia Řím, 2009.

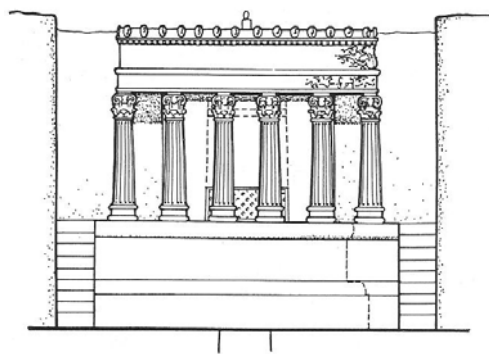

31

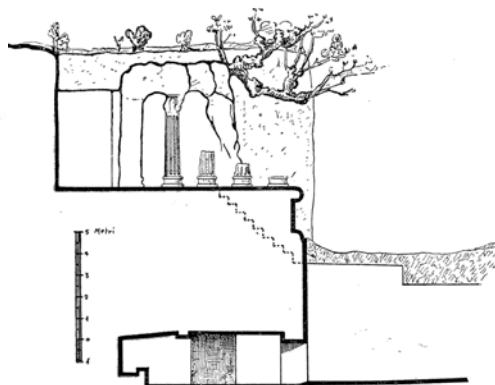
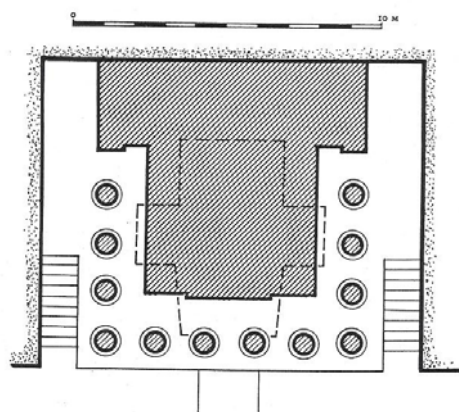

32

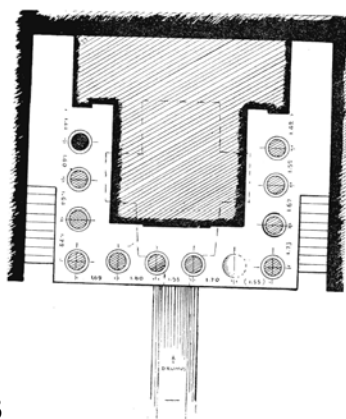

33

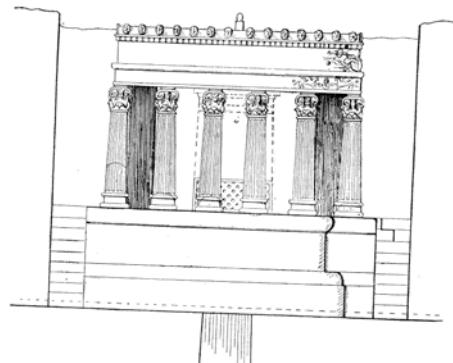

34

31. Tomba Ildebranda, Sovana, 2. století př. Kr., BOUZEK 2003, s. 86, obr. 19.
 32. Tomba Ildebranda, Sovana, 2. století př. Kr., BIANCHI-BANDINELLI 1929, s. 71, obr. 23.
 33. Tomba Ildebranda, Sovana, 2. století př. Kr., BIANCHI-BANDINELLI 1929, s. 85, obr. 32.
 34. Tomba Ildebranda, Sovana, 2. století př. Kr., BIANCHI-BANDINELLI 1929, s. 88, obr. 33.



35

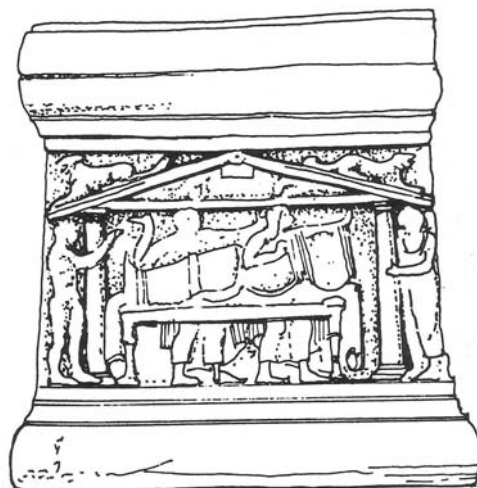

35a

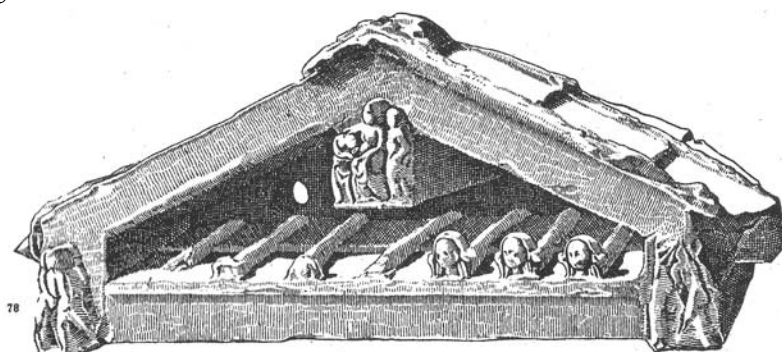

78



36. 36a



34a



37

34a. Norchia, kresebná rekonstrukce, LUKAN 1973, s. 5.

35. Cippus z Chiusi (Clusia) s frontonem chrámu, 500 př. Kr., Státní muzea Berlín, DUCATI 1977, obr. 79.

35a. Cippus z Chiusi (Clusia) s frontonem chrámu, 500 př. Kr., Státní muzea Berlín, BOUZEK 2003, s. 81, obr. 14.

36. Votivní chrám z Nemi, DUCATI 1977, obr. 78.

36a. Votivní chrám z Nemi, BLOCH 1965, obr. 10

37. Urna z Volterra, 3. století př. Kr.



38



38a



39

40

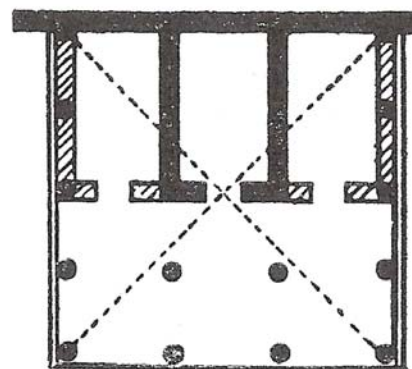
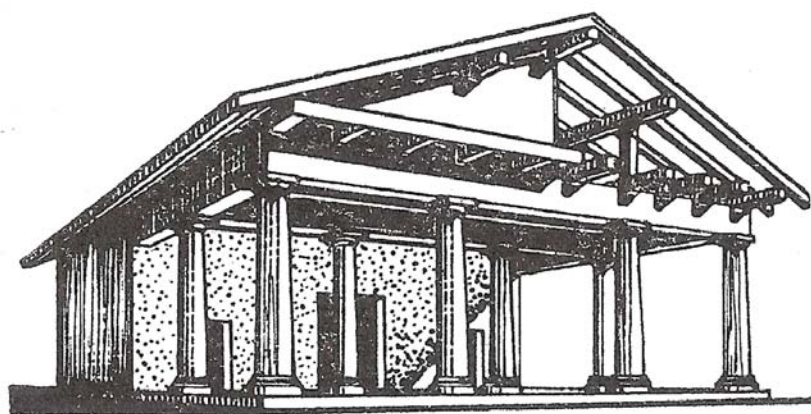

38. Model chrámu ve Vulci, 3. století př. Kr., Museum di Villa Giulia Řím.

38a. Urna ve tvaru chrámku, z Cecciny, DUCATI-GIGLIOLI 1972, s. 119, fig. 11b.

39. Mince M. Volteius s chrámem Jupitera Optima Maxima, GJERSTAD 1966, s. 399, obr. 106.

40. Rekonstrukce etruského chrámu dle Vitruvia.

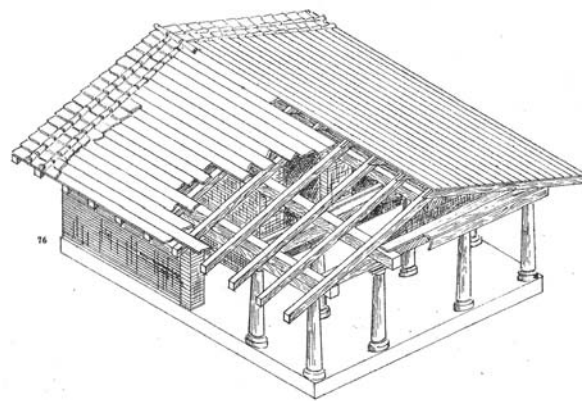

41

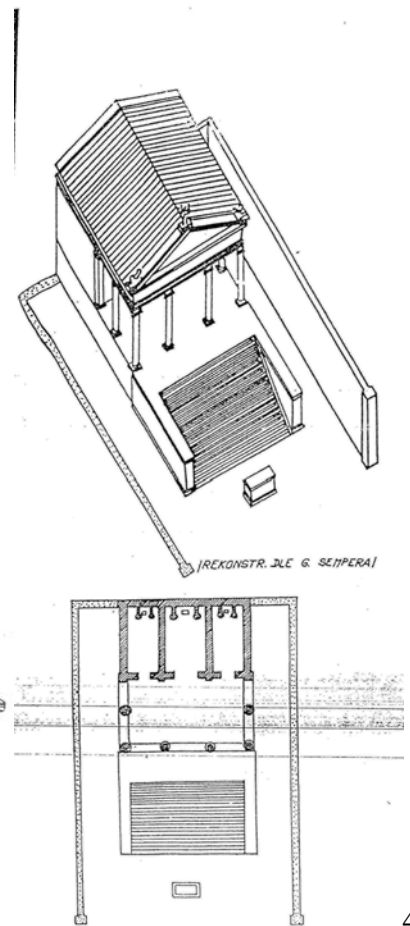

42

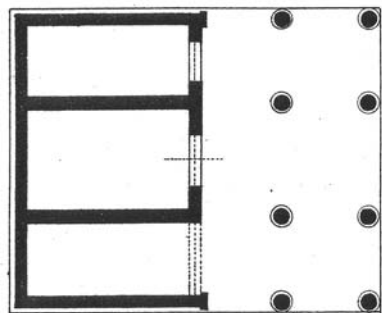

43



44

41. Rekonstrukce etruského chrámu dle Wieganda, DUCATI 1977, obr. 76.
 42. Rekonstrukce etruského chrámu dle Sempera, HANUŠ-BENEŠOVÁ 1978, s. 220.
 43. Půdorys chrámu dle Vitruvia, DUCATI 1977, obr. 77.
 44. Model chrámu (*Mir Etruskov*) kolem roku 500 př. Kr.

Tuskischer Tempel des Vitruv – nach Fra Giocondo.

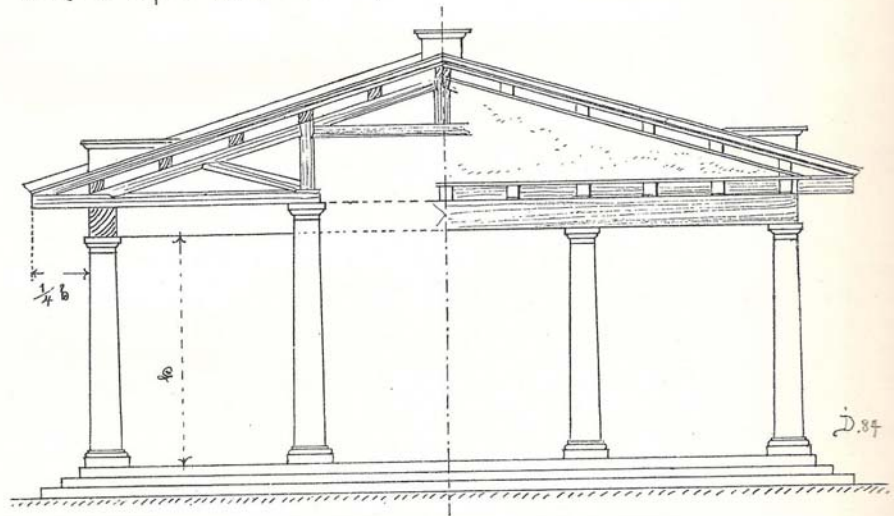

45

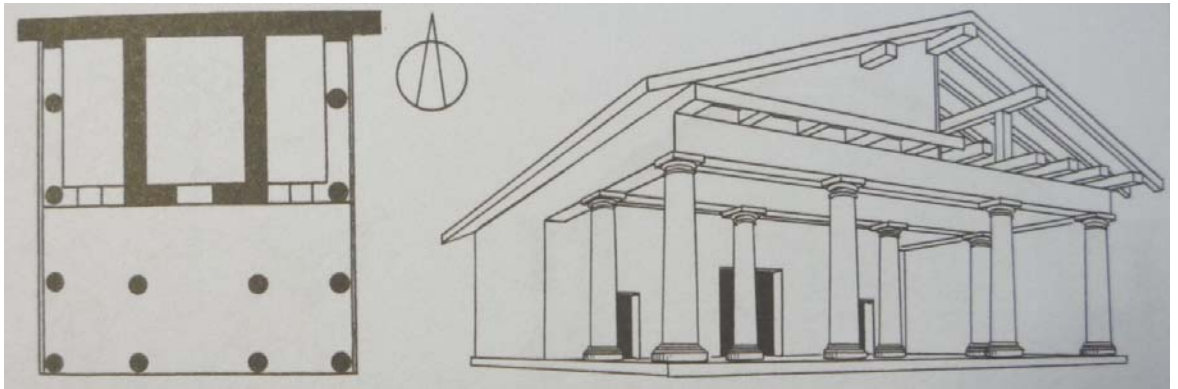

46



47



48

45. Tuskánský chrám dle Vitruvia dle Fra Gioconda, DURM 1905, obr. 109.

46. Rekonstrukce vitruviánského chrámu dle Borrmanna a Wieganda.

47. Model chrámu okolo 500 př. Kr. (*Die Welt der Etrusker* 1988).

48. Rekonstrukce chrámu dle Vitruvia, Gottfried Semper, 1978, SPIVEY 1997, s. 61, obr. 43.

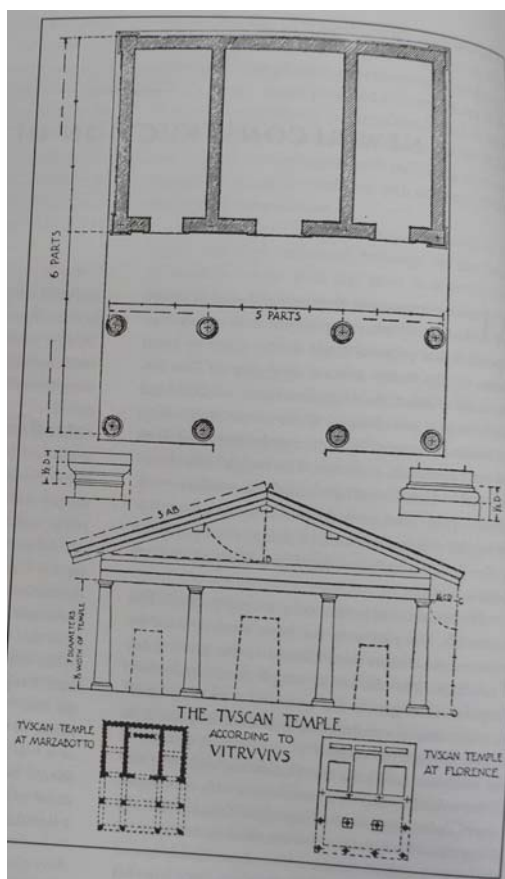

49, 50

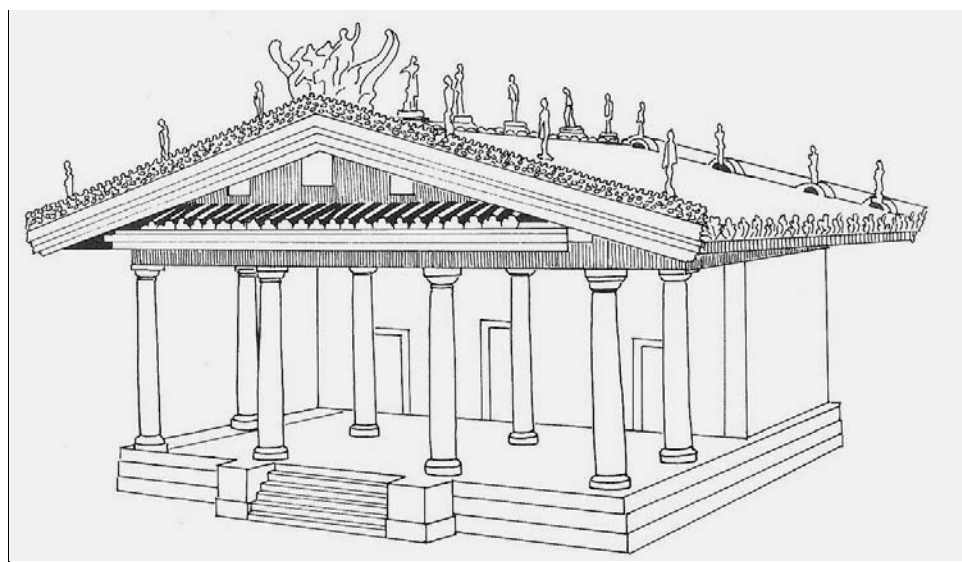
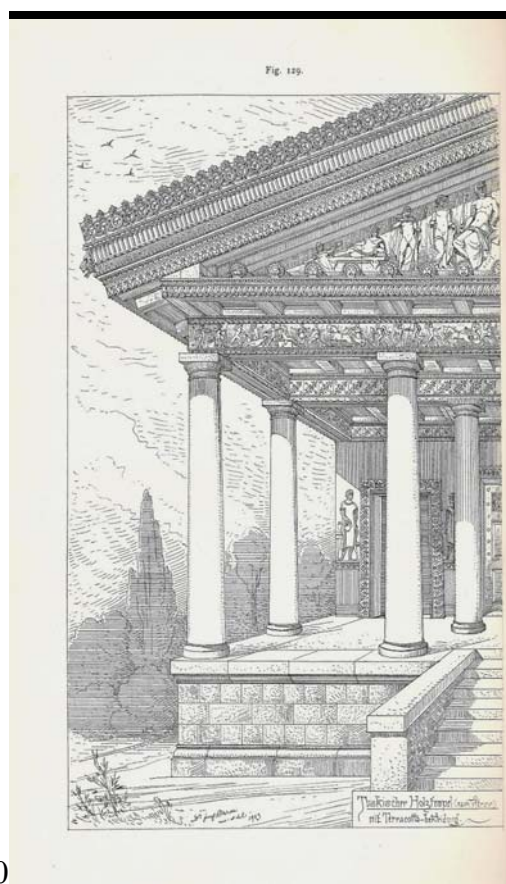

51

49. Etruský chrám dle Vitruvia: rekonstrukce dle H. L. Warrena, STAMPER 2005, s. 20, obr. 8.

50. Rekonstrukce chrámu, DURM 1905, s. 116, obr. 129.

51. Ideální rekonstrukce trojcellého chrámu, model institutu pro etruskologii římské university, STÜTZER 1980, s. 144, obr. 94.

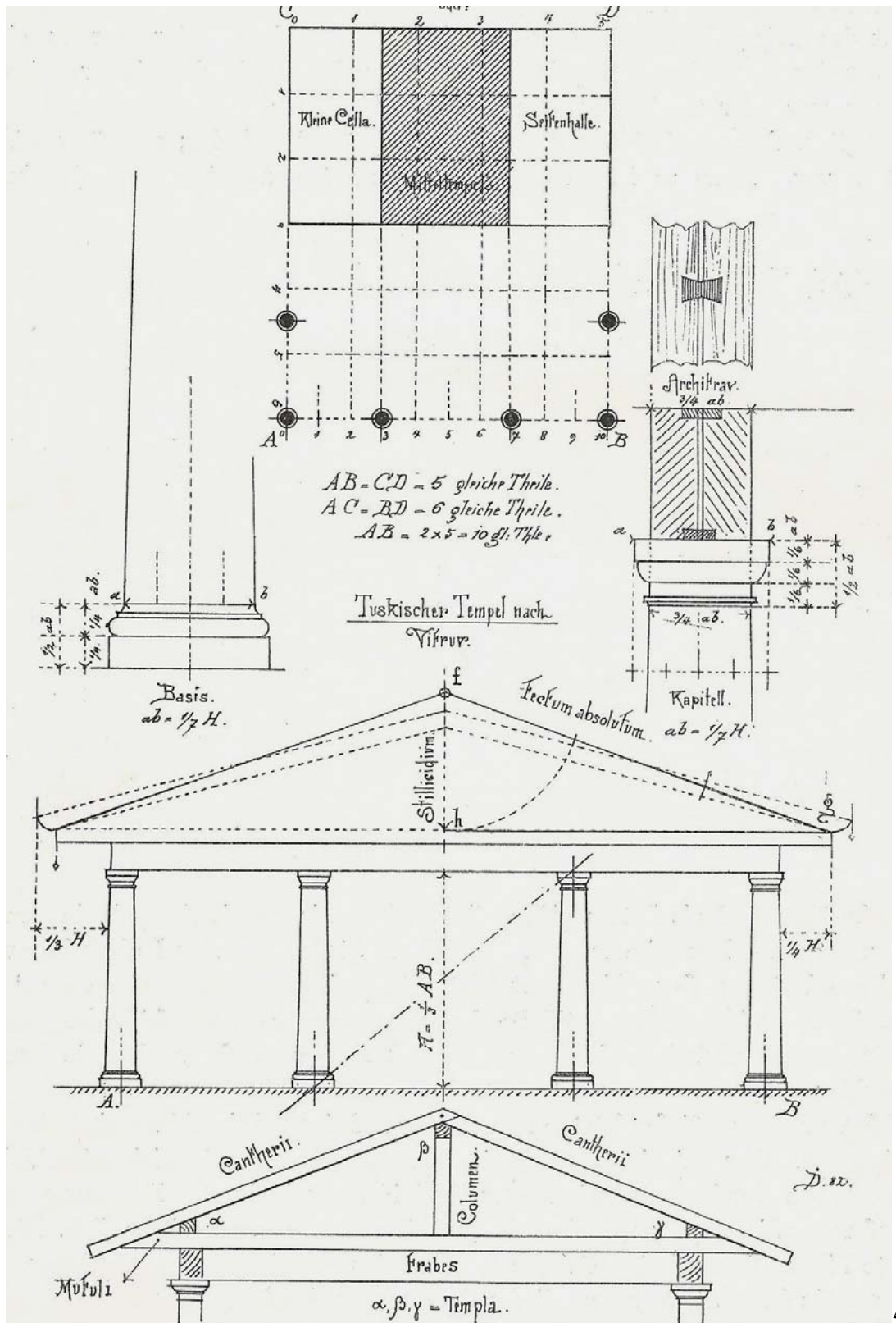

52. Tuskánský chrám dle Vitruvia, DURM 1905, s. 97, obr. 108.

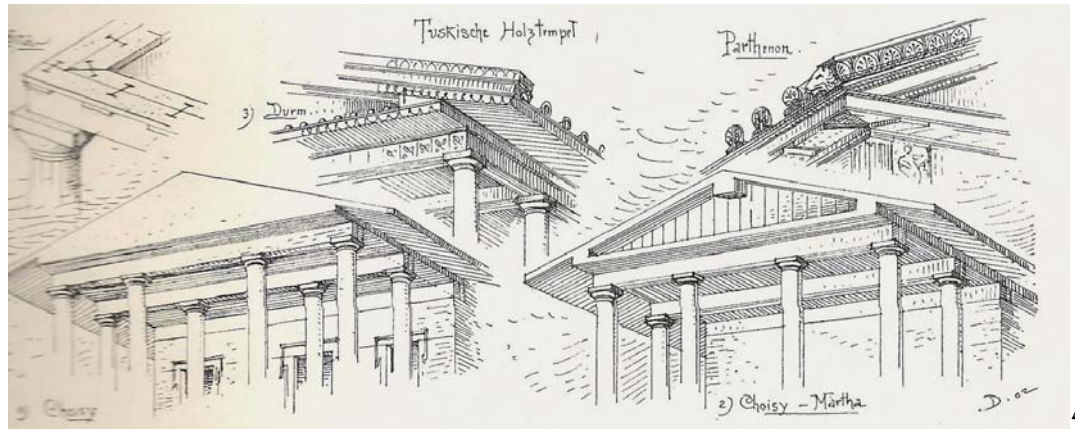

53

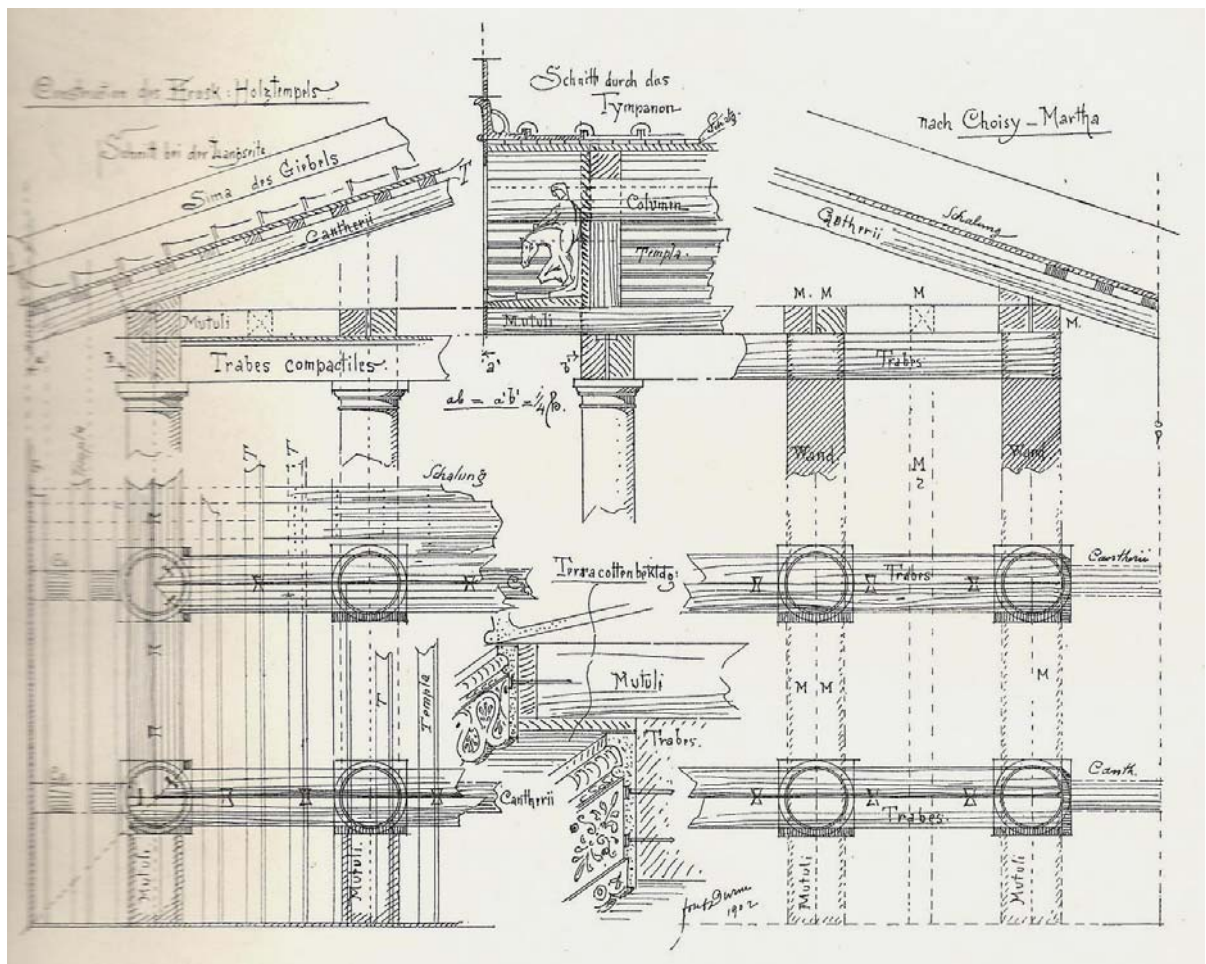

54

53. Střecha chrámu, DURM 1905, s. 115, obr. 128.

54. Rekonstrukce chrámu, DURM 1905, s. 115, obr. 127.



Toskánský řád. Albano, 1. stol. př. Kr.

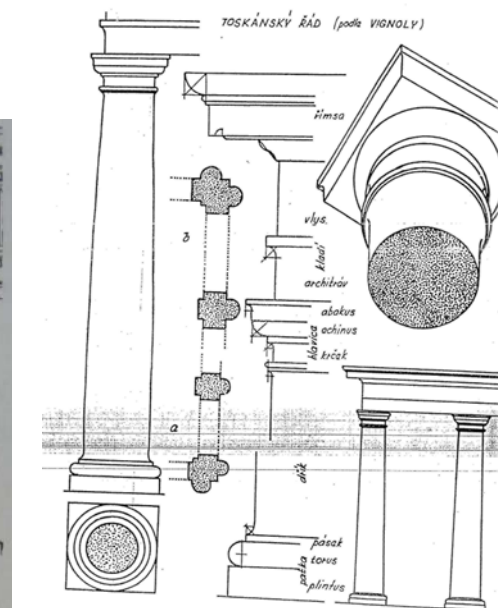

55

56



57

55. Toskánský řád, KOCH 1998, s. 33.

56. Toskánský řád dle Vignoly, HANUŠ-BENEŠOVÁ 1978, s. 224.

57. Ideální rekonstrukce etruského trojcellého chrámu, kresba modelu Musea Institutu pro etruskologii, Universita Řím.

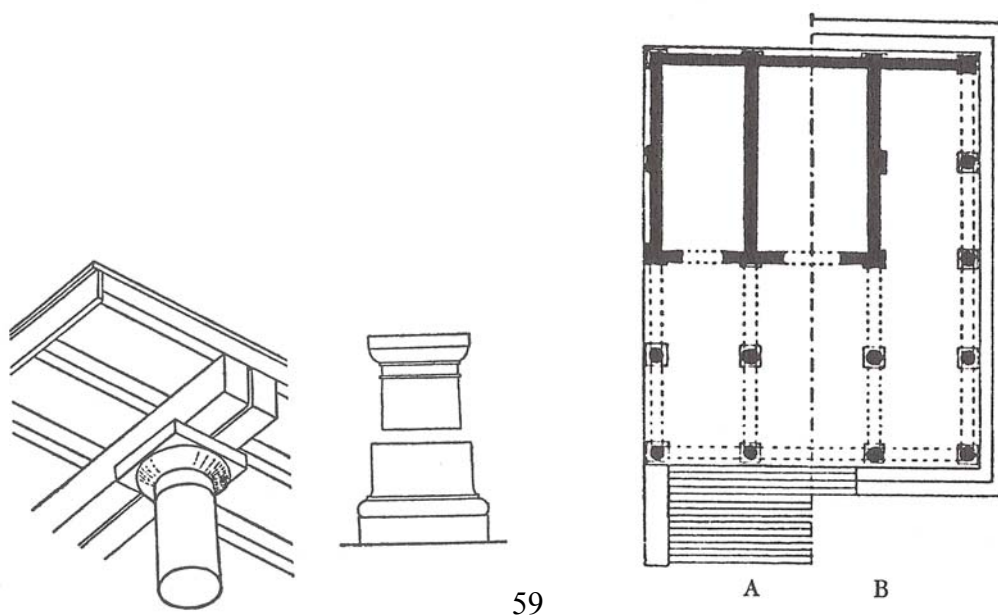
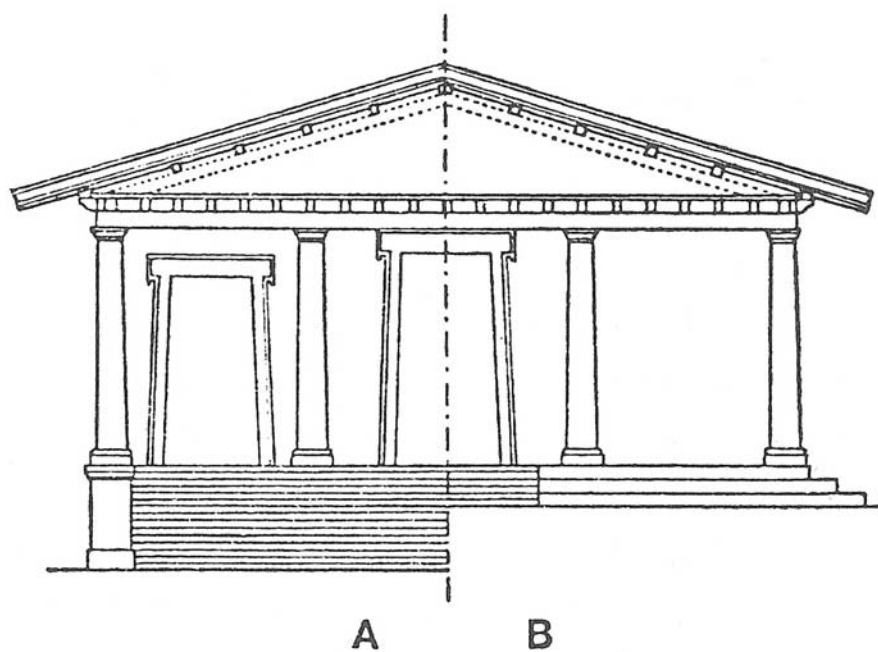

59

60

58. Srovnání čelního pohledu pódiového (A) a stupňového chrámu (B), VITRUVIUS, s. 148, obr. 46.

59. Kladi, hlavice a patka sloupů etruského řádu, VITRUVIUS, s. 149, obr. 46.

60. Srovnání půdorysů pódiového (A) a stupňového chrámu (B), VITRUVIUS, s. 148, obr. 45.



61



62



63

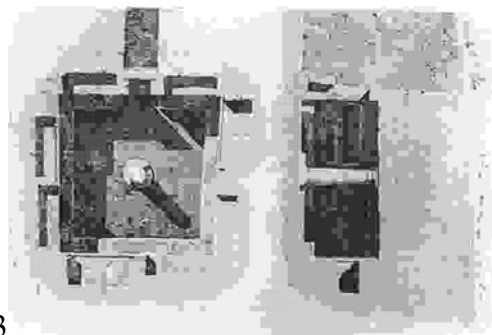

64



65



66

61. Tomba delle colonne doriche, Caere, foto z r. 1958, BOËTHIUS 1962, pl. 64, fig. 5.
62. Čtvercový pilř v hrobce 197, Caere, BOËTHIUS 1962, pl. 64, obr. 4.
63. Čtvercový pilř ve hrobce 198, Caere, BOËTHIUS 1962, pl. 63, obr. 3.
64. Centrální sloup faliské hrobky, Vignanello, BOËTHIUS 1962, pl. 63, fig. 1.
65. Rektangulární pilastr u zadní stěny hrobky č. 57, Caere, BOËTHIUS 1962, pl. 63, obr. 2.
66. Tomba della principessa Margrete di Danimarca, San Giuliano, foto z r. 1958, BOËTHIUS 1962, pl. 64, obr. 6.

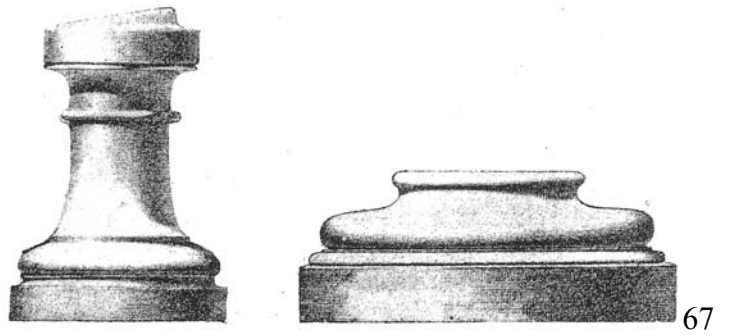

67



68

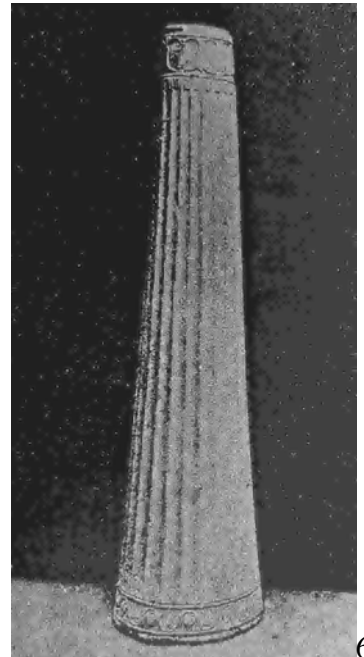

69

67. Baze sloupu z Orvieto, DUCATI 1977, obr. 81.
68. Tomba dei Capitelli v Cerveteri, DUCATI 1977, tav. 25, obr. 84.
69. Sloup z Orvieto, DUCATI 1977, tav. 25, obr. 85.

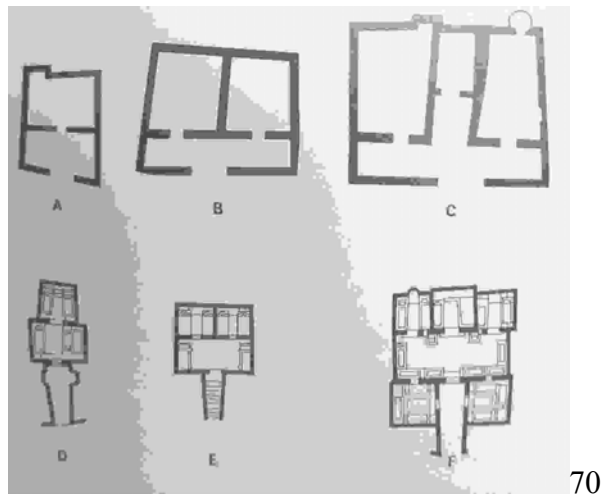

70

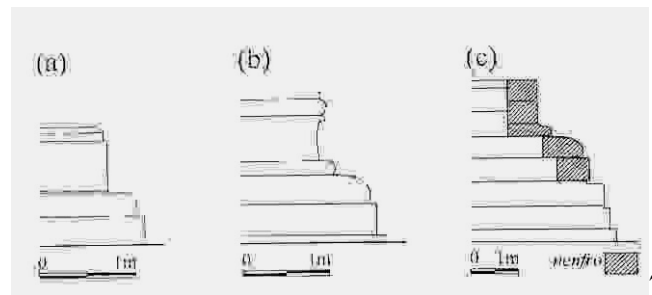

71

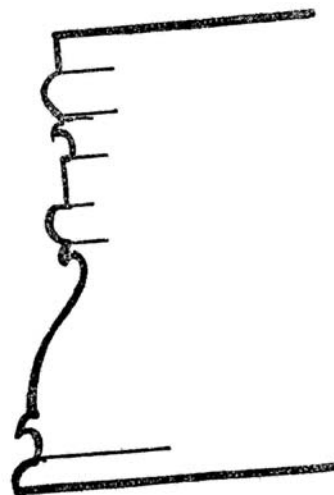

72



73

70. Typy etruských domů (6. století př. Kr., A-C) ve srovnání s typy hrobek (Cerveteri, D-F), CRISTOFANI, BARKER-RASMUSSEN 2005, s. 226, obr. 89.

71. Profily a) oltář z Punta della Vipera b) oltář z Vignanella c) baze chrámu Ara della Regina v Tarquinii, IZZET 2001, s. 192, fig. 2.

72. Profil oltáře, Sovana, BIANCHI-BANDINELLI 1929, s. 52, obr. 12.

73. Kampánská destička (malovaná terakota) – muž před oltářem, 530 – 520 př. Kr., Louvre (6626), PRAYON 1986, s. 198, obr. V-44.

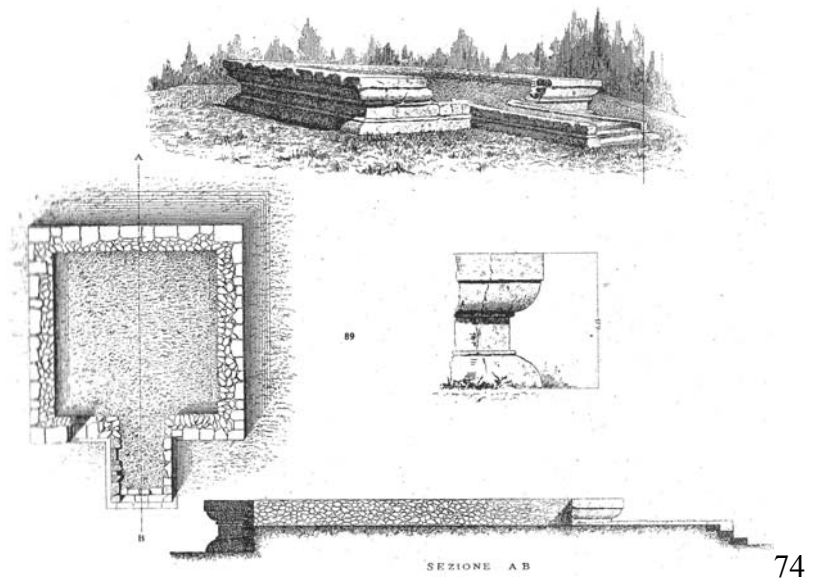

74



75

74. Marzabotto, oltář D, DUCATI 1977, s. 88, obr. 89.

75. Marzabotto, oltář D, PRAYON 1986, s. 198, obr. V-45.

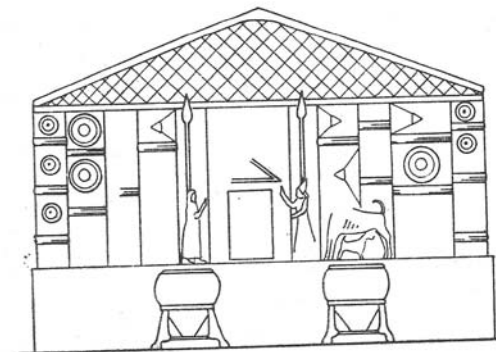

76, 77

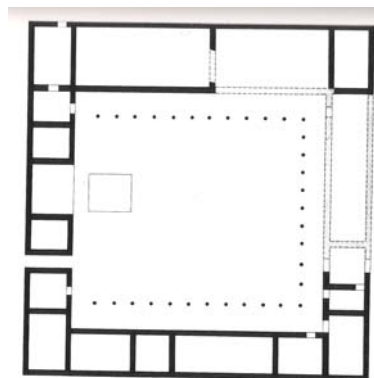

78

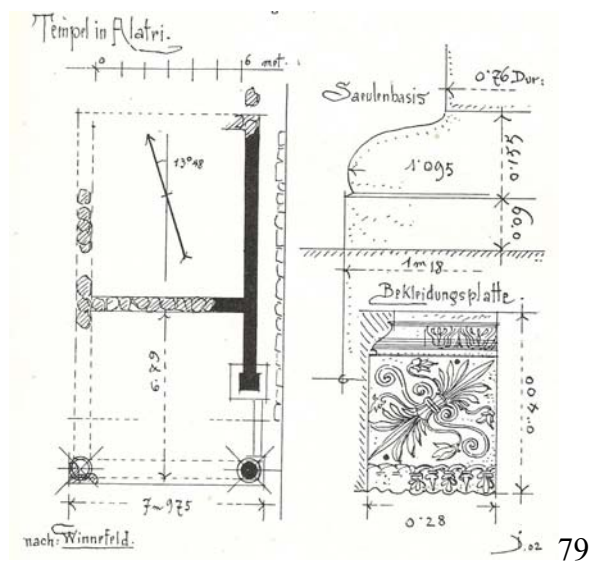

79

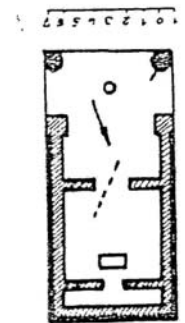

80

76. Chrám Urartu na Araratu, asyrský reliéf z 8. století př. Kr., Chorsabád.
 77. Oltáře v Lanuviu, De PUMA-SMALL.
 78. Archaická budova v Murlo u Sieny, PRAYON 1986, s. 192, obr. 33.
 79. Chrám v Alatri dle Winnefeldta, DURM 1905, s. 111, obr. 121.
 80. Půdorys chrámu v Alatri, HANUŠ-BENEŠOVÁ 1978, s. 223.

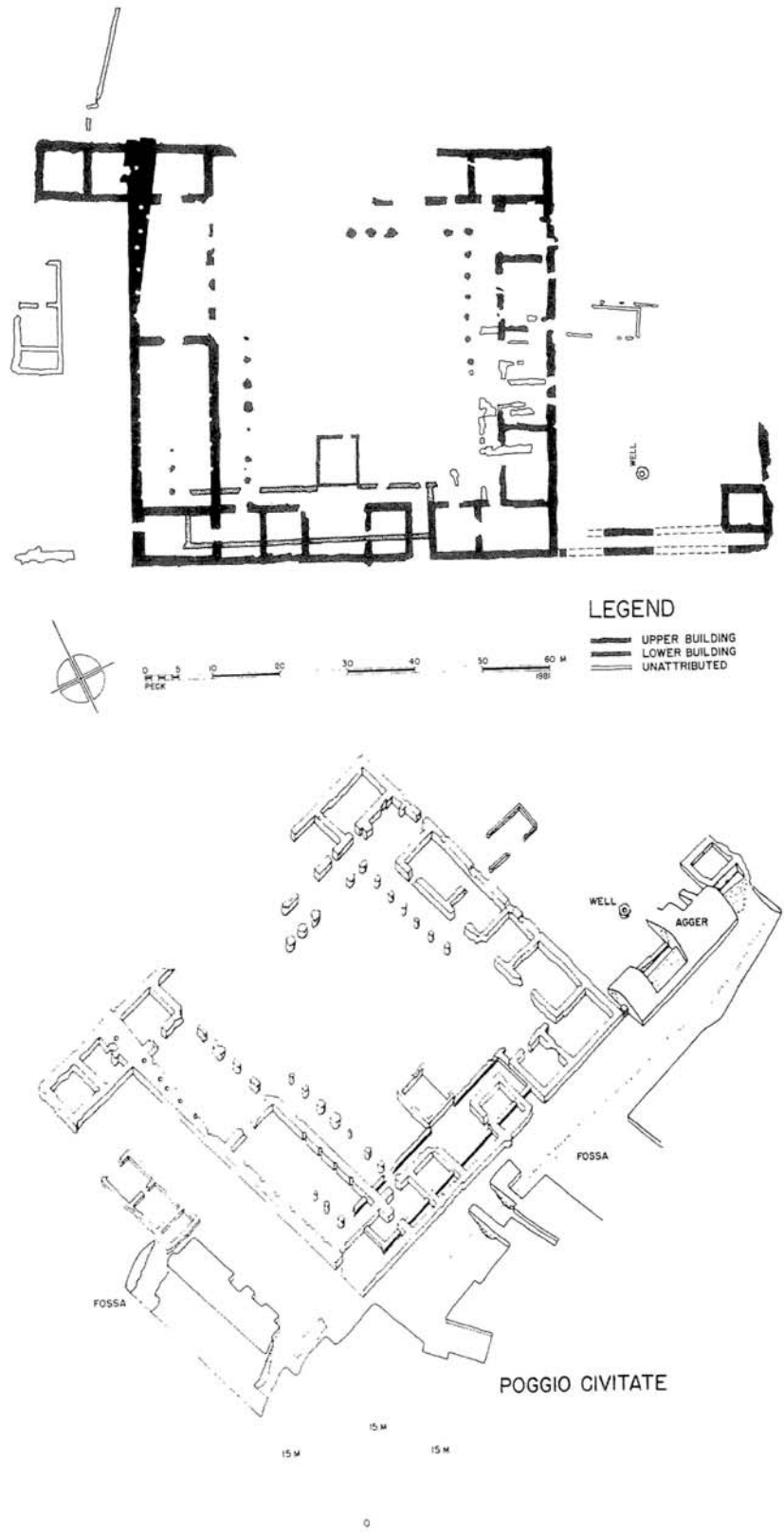
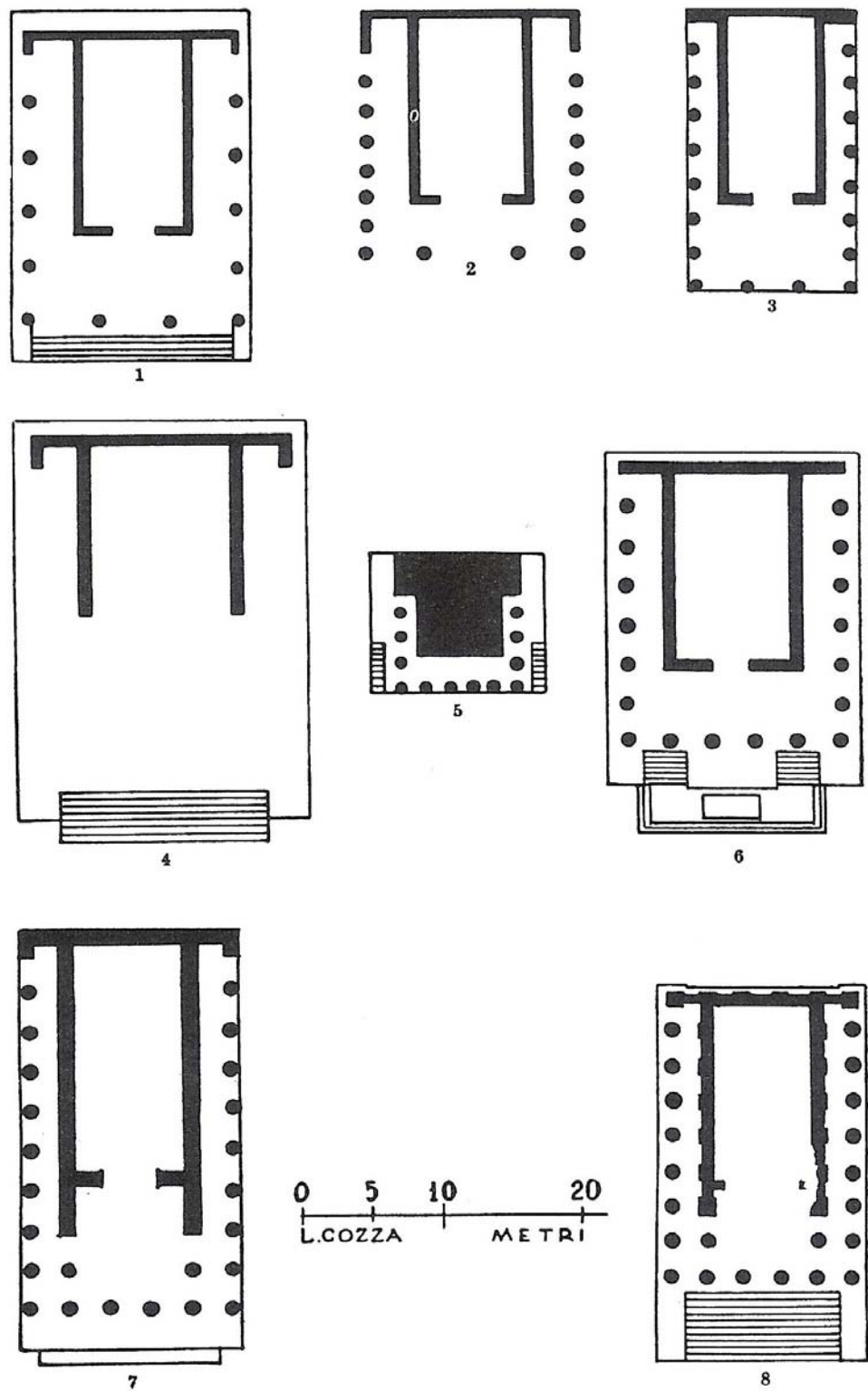
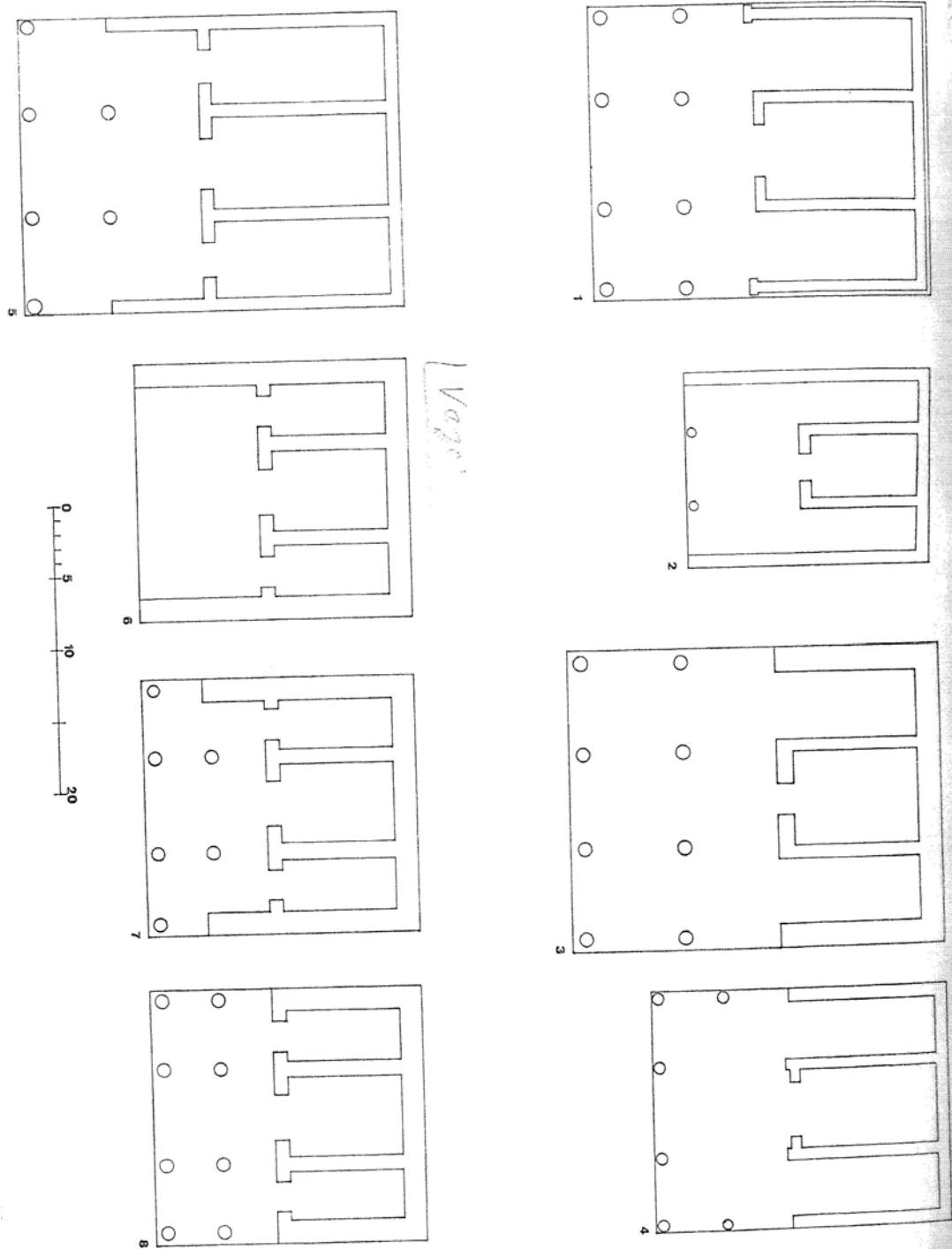

Fig. 8 A—B. Poggio Civitate (Murlo): plan of upper building (by D. Peck).



82. Peripteros sine postico (1. Largo Argentina 2. Ariccia 3. Paestum 4. Cascia 5. Sovana 6. Gabi 7. Giove Statore 8. Foro Olitorio), CASTAGNOLI 1955, s.140.



82a

82a. 1. Tuskánský chrám s alaemi (Wiegandova rekonstrukce) 2. Chrám ve Fiesole (podle Maetzkeho) 3. Chrám v Lanuviu (hypotetická rekonstrukce) 4. Chrám Diany Tifatiny (idem) 5. Capitolium v Cose (dle Browna) 6-8. Chrám se třemi cellami ve Vejích (tři hypotézy Stefaniho), CASTAGNOLI 1966/67, s. 10 – 14, s. 13.

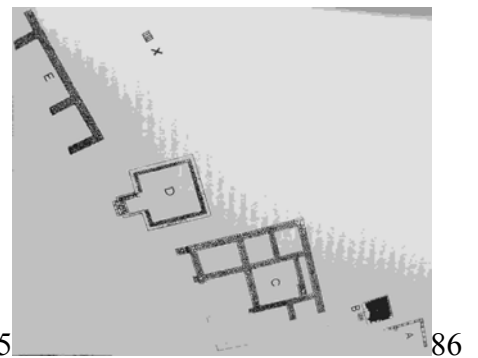
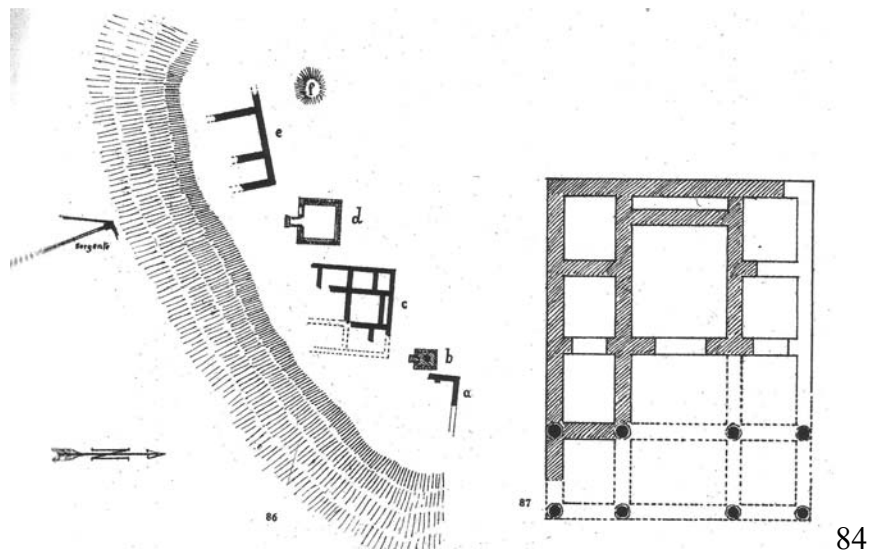
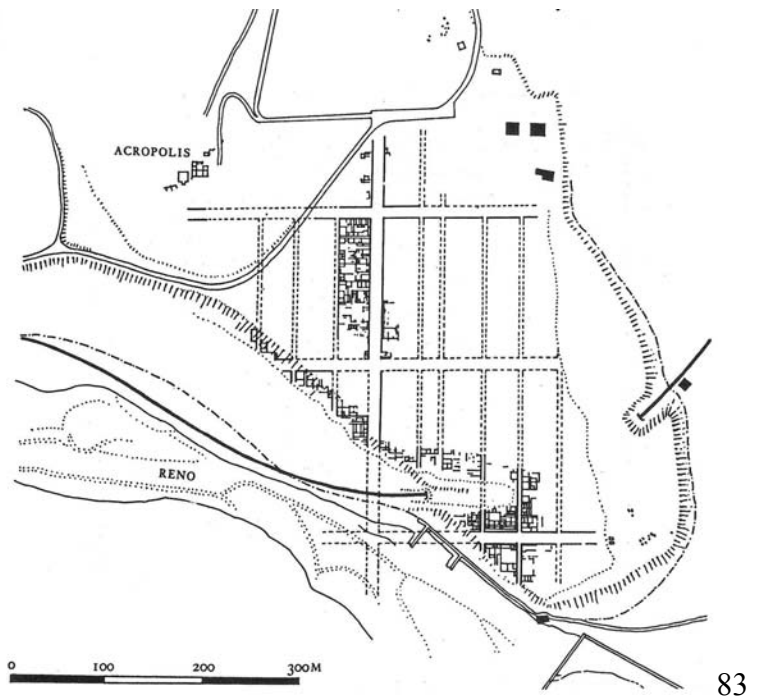

83. Marzabotto cca 500 př. Kr., BOUZEK 2003, s. 87, obr. 21.
 84. Marzabotto, místo a chrám, cca 500 př. Kr., DUCATI 1977, s. 86, obr. 87.
 85. Svatyně u pramene v Marzabottu, EDLUND-BERRY 1987, s. 69, obr. III. 5.
 86. Marzabotto, *Guida alla città' etrusca* 1983, s. 103, obr. 91.



87



88

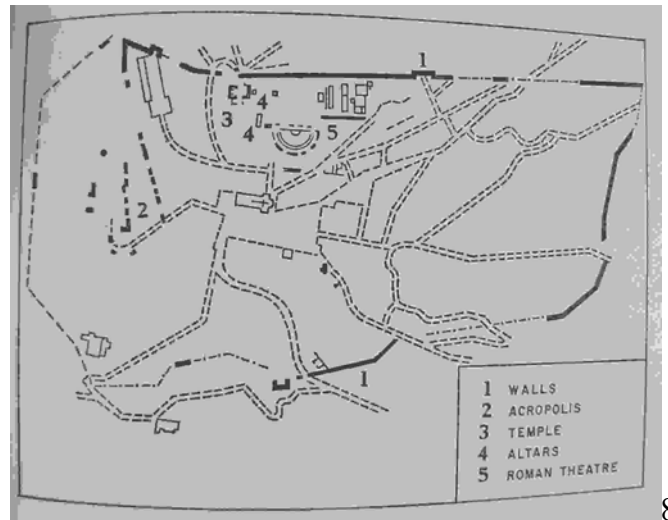

89

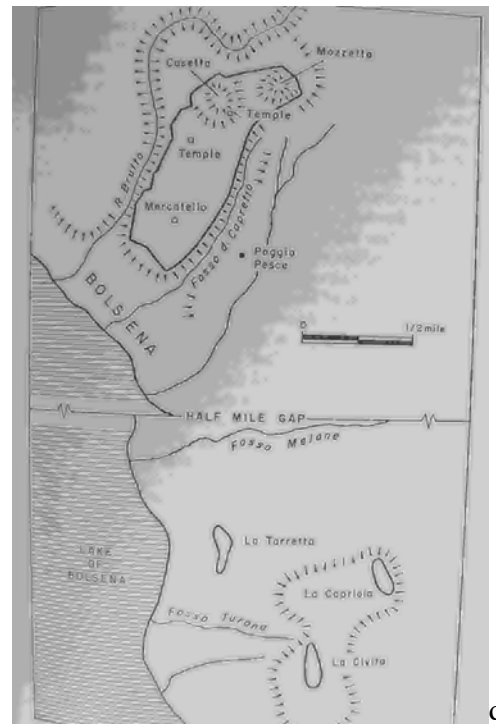

90

87, 88. Marzabotto, schody na pódium a pódium D, *Guida alla citta' etrusca* 1983, s. 106, obr. 92.

89. Faesulae s moderním plánem cest, SCULLARD 1967, s. 169, fig. 21.

90. Bolsena – Volsinii, SCULLARD 1967, s. 129, fig. 15.

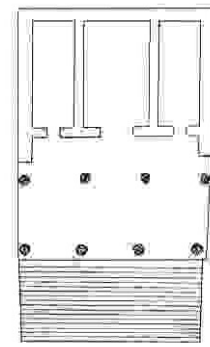
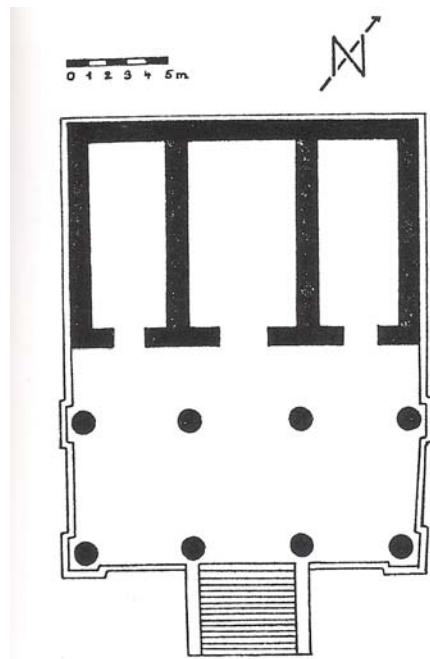

91

92

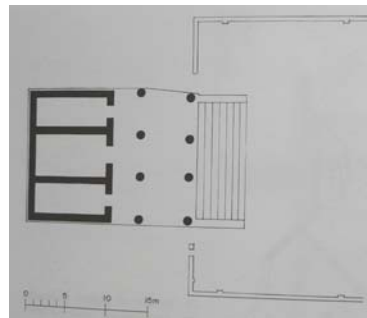

93

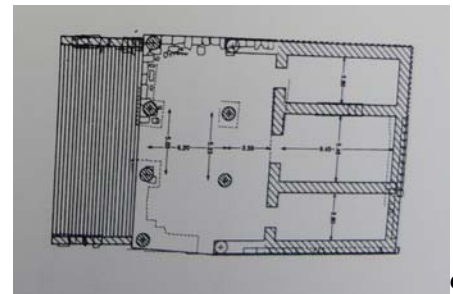

94



95

91. Chrám Belvedere v Orvietu se třemi cellami, 5. století př. Kr., STÜTZER1980, s. 142, obr. 93a, PRAYON 1986, s. 197, obr. V-41.

92. Chrám Belvedere v Orvietu, IZZET 2001, s. 195, fig. 5.

93. Chrám v Orvietu, STAMPER 2005, s. 30, obr. 19.

94. Orvieto, *Italien vor den Römern*, s. 52.

95. Orvieto, informační tabule.



96



97



98

96. – 98. Orvieto, 2009.



105

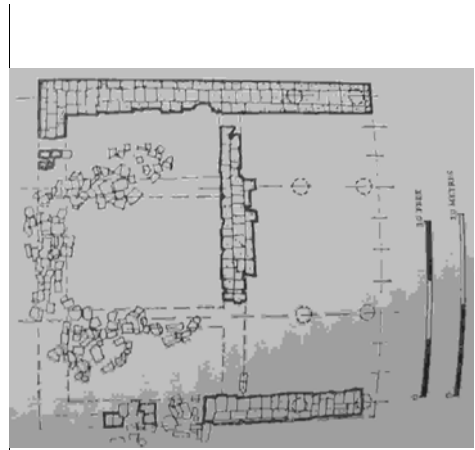

106



107



108



109



110

105., 107. – 110. Portonaccio, Veje.

106. Půdorys chrámu, PRAYON 1986, obr. V-39, 100, BOUZEK 2003, s. 82, obr. 15B.



111

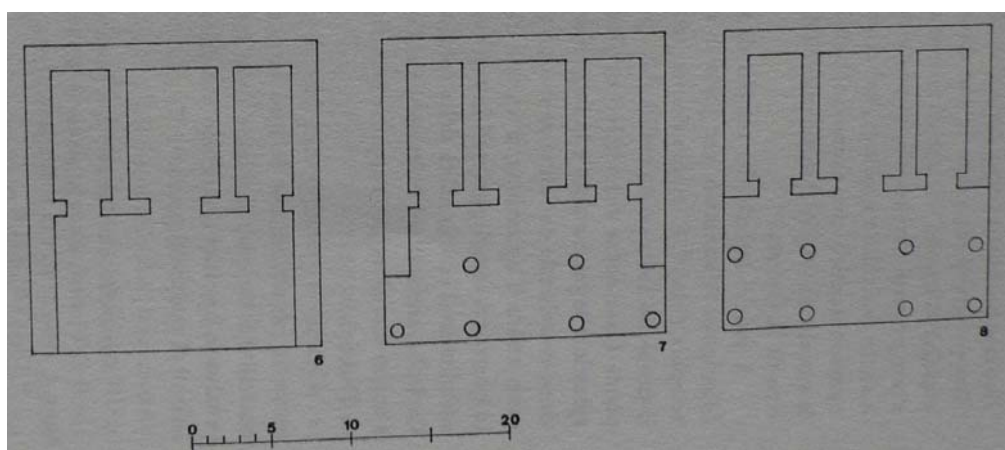

112



113

111. Rekonstrukce chrámu Portonaccio ve Vejích, SPIVEY 1997, s. 63, obr. 44.
 112. Veje, 3 hypotézy, rekonstrukce Stefaniho, CASTAGNOLI 1966/67, s. 13, obr. 6.
 113. Portonaccio, Veje, EDLUND-BERRY 1987, s. 65, obr. III.4.

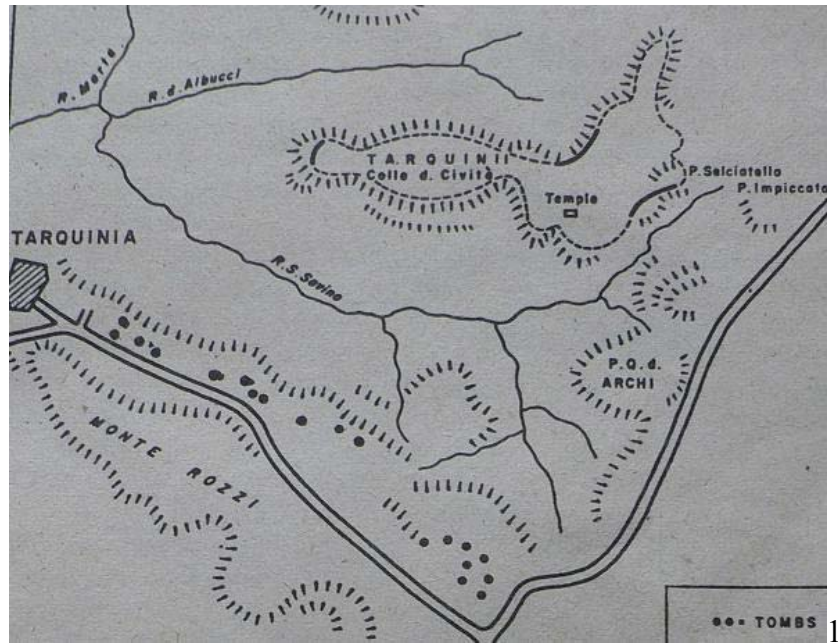

114



115

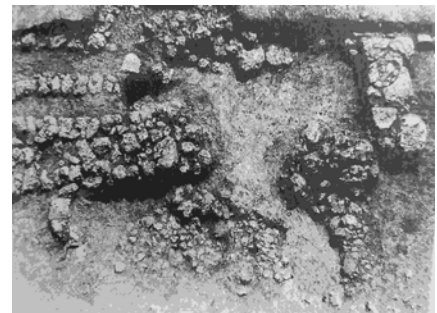

116

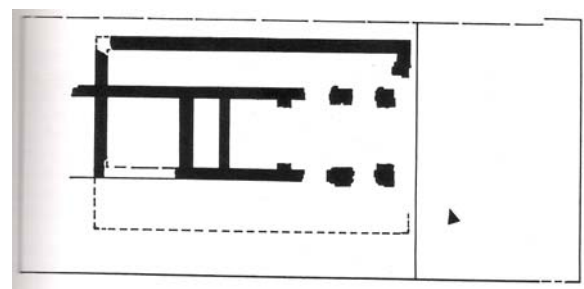

117

114. Ara della Regina, Tarquinie, HEJZLAR, s. 29, obr. 5.
 115. Ara della regina, Tarquinie
 116. Tarquinia, drenážní kanály, RASMUSSEN 1996, s. 53, fig. 10.
 117. Ara della Regina, Tarquinie, BOUZEK 2003, s. 83, obr. 16.

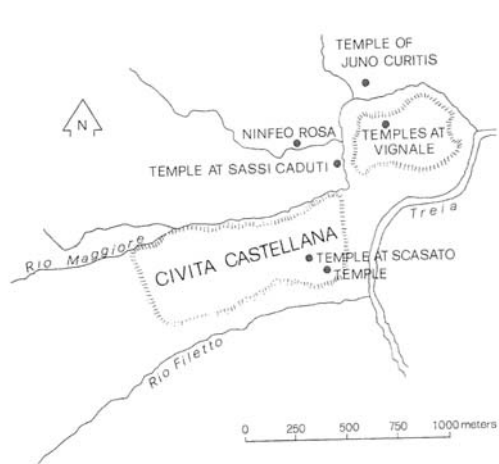

118.

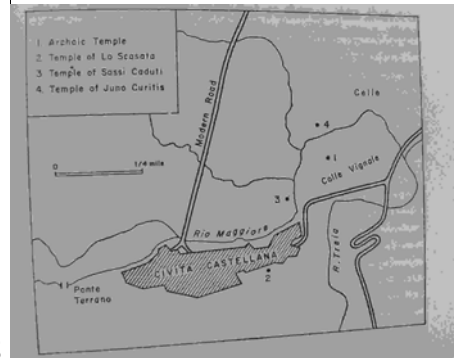

119

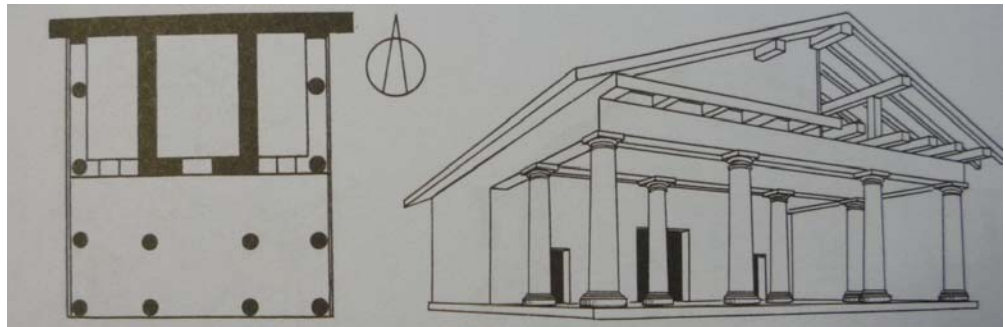

120



121

118. Civita Castellana, EDLUND-BERRY 1987, s. 74, fig. 5.

119. Civita Castellana, SCULLARD 1967, s. 113, fig. 12.

120. Civita Castellana, KOCH 1998.

121 Civita Castellana, EDLUND-BERRY 1987, s. 74, obr. III.6.

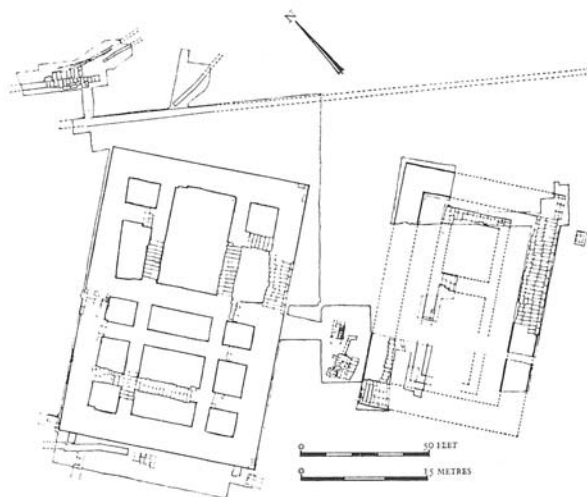

122

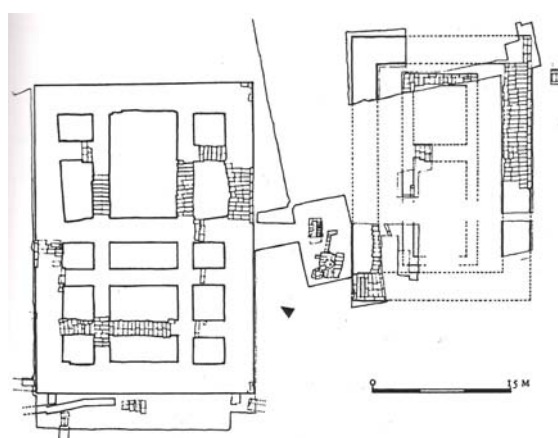

123

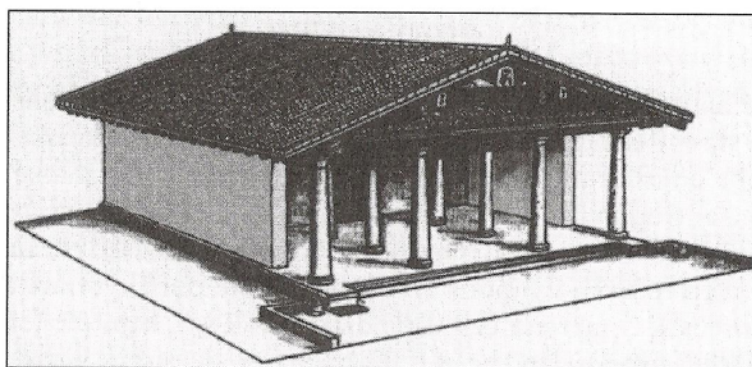

124

122. Pyrgi, St. Severa, rané 5. století př. Kr., PRAYON 1986, s. 197, obr. V-42.

123. Pyrgi, St. Severa, rané 5. století př. Kr., BOUZEK 2003, s. 85. obr. IX-17.

124. Model rekonstrukce chrámu A v Pyrgi, BARKER-RASMUSEN 2000, s. 214, obr. 78, Museo di Antichita Etrusche e Italiche, Universita La Sapienza Řím.



125

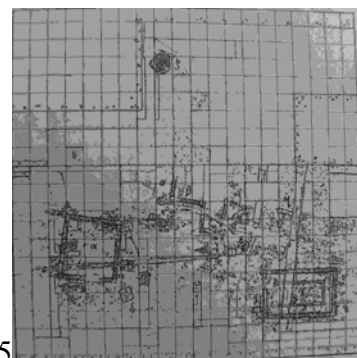

126

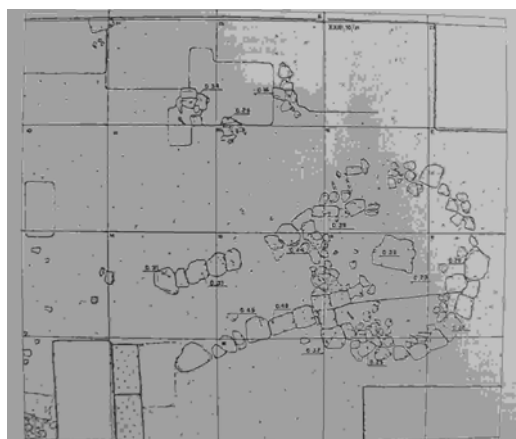

127



128



129

125. Pyrgi, RASMUSSEN 1996, s. 49, fig. 1.

126. Pyrgi – sacella, RASMUSSEN 1996, s. 51, fig. 4.

127. Pyrgi – oltář nebo baze monumentu, RASMUSSEN 1996, s. 50, fig. 2.

128. Pyrgi, chrám B od jihu, pronaos a cella, RIDGWAY 1980, s. 67, fig. 17.

129. Pyrgi, oltář α a oltář δ, RASMUSSEN 1996, s. 51, fig. 5.



130



131



132

130. Gravisca, *Murlo and the Etruscans*.

131. Pieve Socana, oltář a chrám, EDLUND-BERRY 1987, s. 79, obr. III.7.

132. Lucus Feroniae, fórum a oltář, EDLUND-BERRY 1987, s. 88, obr. III.11.

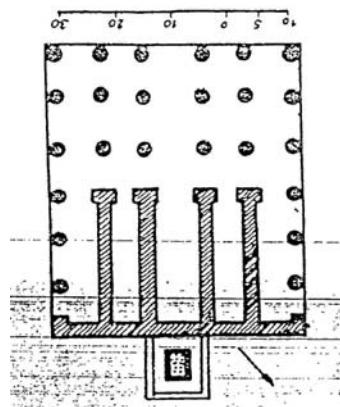

133

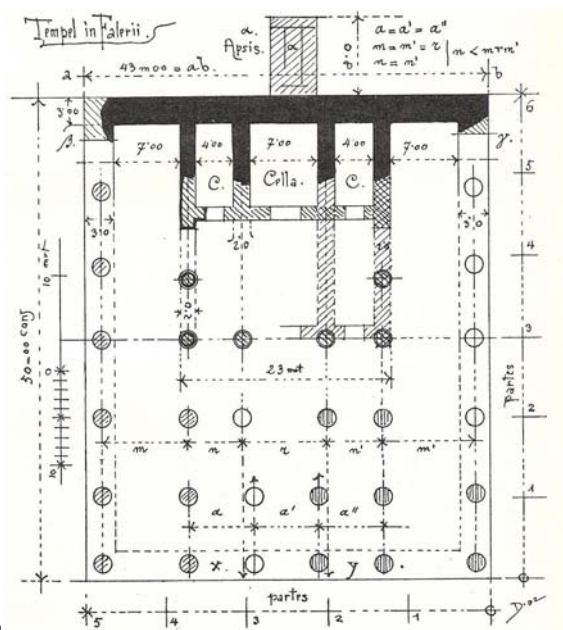

134

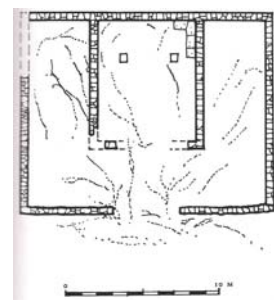

135



136

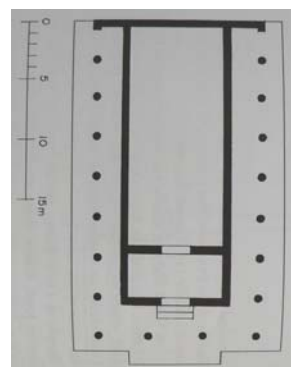

137

133. Chrám Junony, Falerie, Civita Castellana, HANUŠ-BENEŠOVÁ 1978, s. 223.

134. Chrám ve Faleriích, Civita Castellana, DURM 1905, s. 106, obr. 116.

135. Poggio Cassata, Volsinie, rané 6. století, BOUZEK 2003, s. 81, obr. 13.

136. Mapa údolí Arna mezi Arezzem a Monte Falterona, EDLUND-BERRY 1987, s. 79, fig. 6.

137. Satricum, chrám Mater Matuta, STAMPER 2005, s. 30, obr. 20.

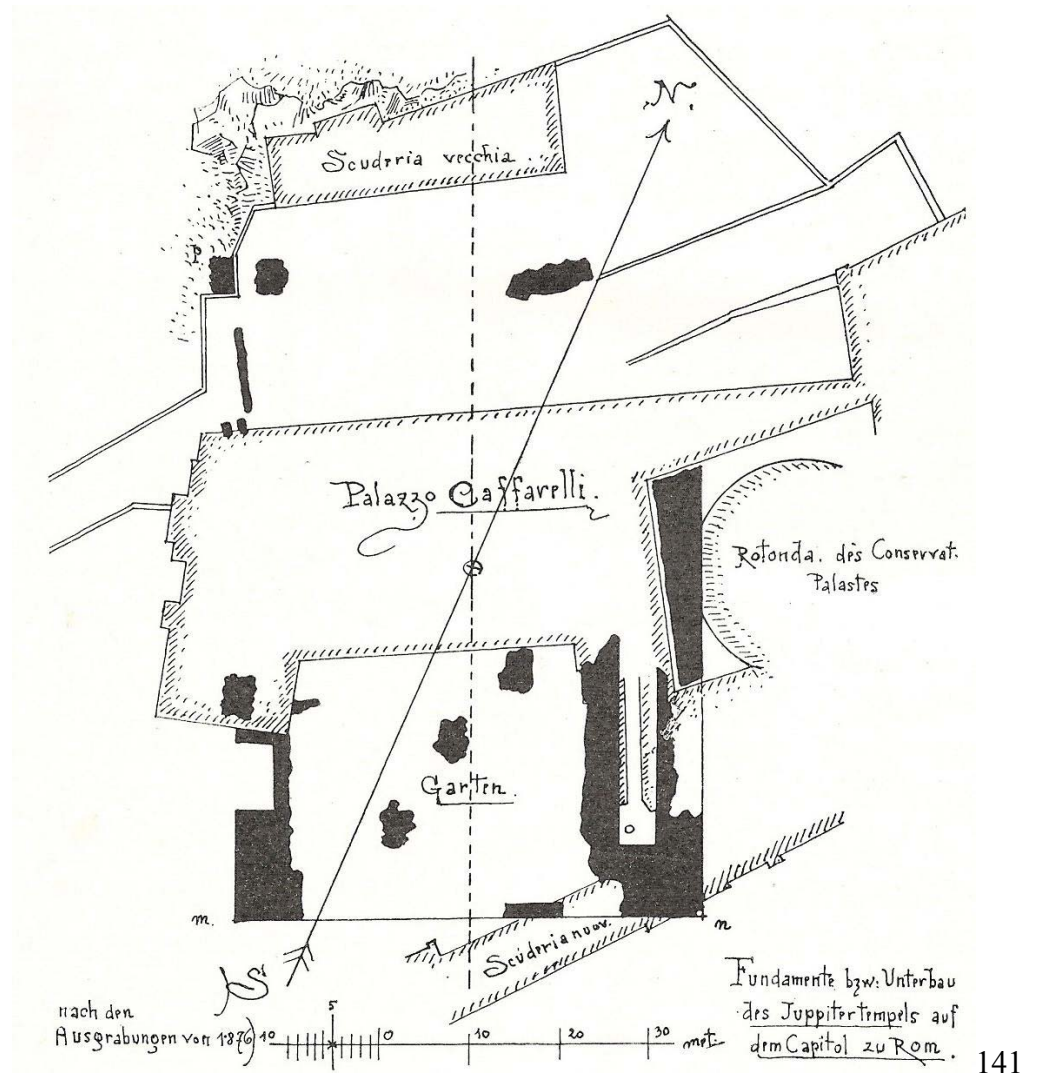
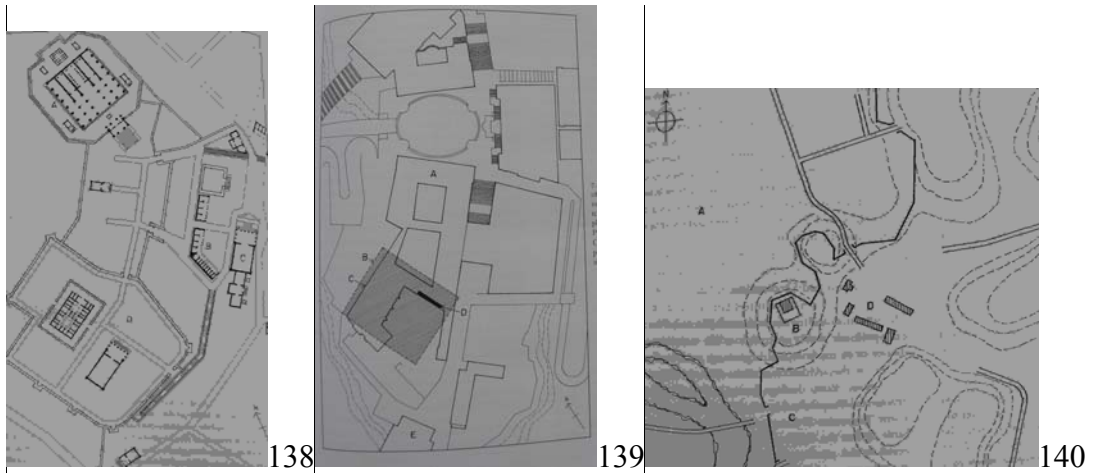

138. Kapitolský kopec, STAMPER 2005, s. 16, obr. 6.
 139. Kapitolský kopec, STAMPER 2005, s. 17, obr. 7.
 140. Capitoline hill, STAMPER 2005, s. 9, obr. 3.
 14.1Kapitol, plán místa, DURM1905, s. 99, obr. 110.

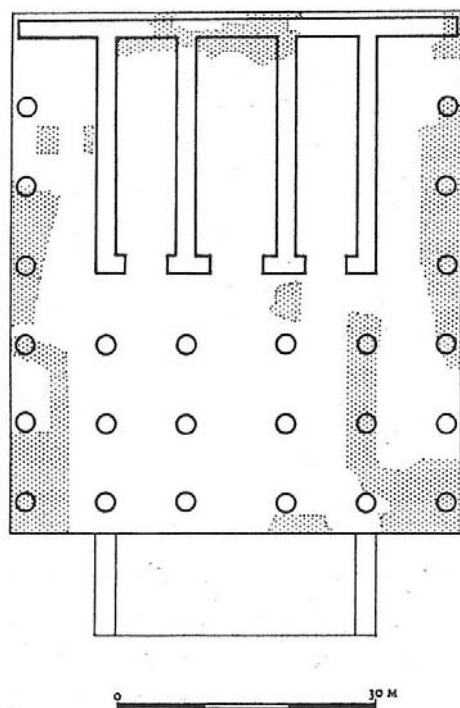

142

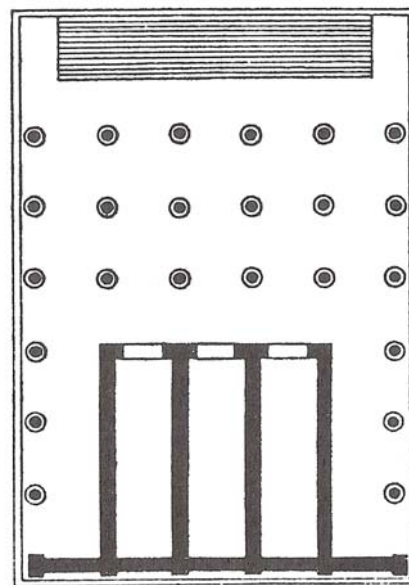

143

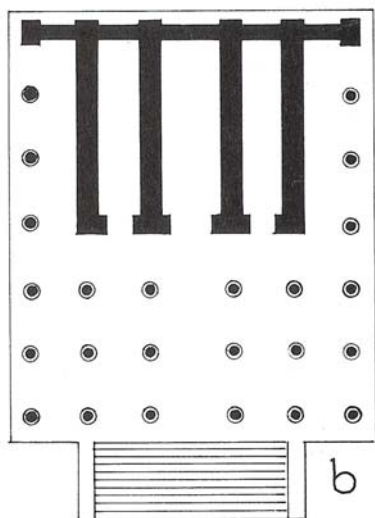

144

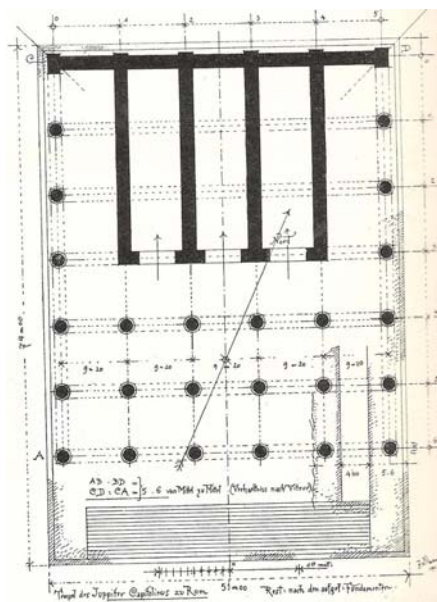

145

142. Chrám Jupiter Optimus Maximus Capitolinus, zasvěcen roku 509 př. Kr., půdorys E. Gjerstada a B. Blomého, BOUZEK 2003, s. 85, obr. 18, PRAYON 1986, s. 198, obr. V-40, STAMPER 2005, s. 24, obr. 12.
143. Chrám kapitolské trojice, Řím, VITRUVIUS s. 151, obr. 48.
144. Chrám kapitolské trojice, Řím, STÜTZER 1980, s. 142, obr. 93b.
145. Chrám kapitolské trojice, Řím, DURM 1905, s. 100, obr. 111.

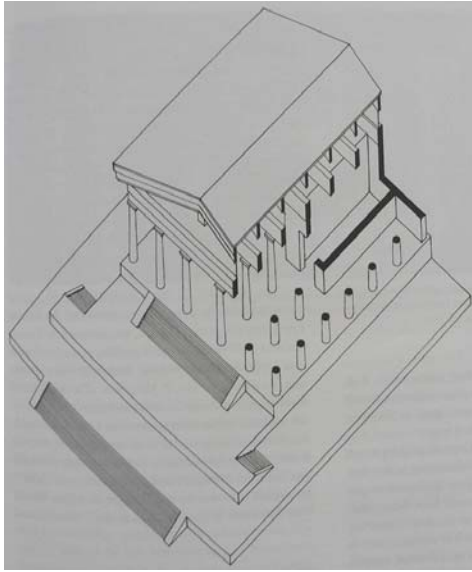

146

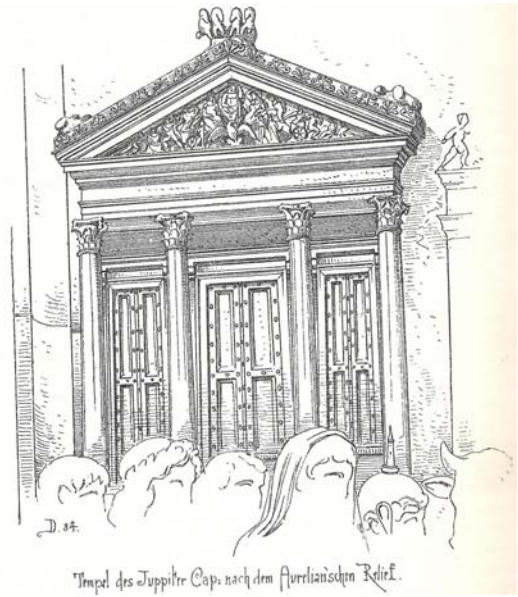

147

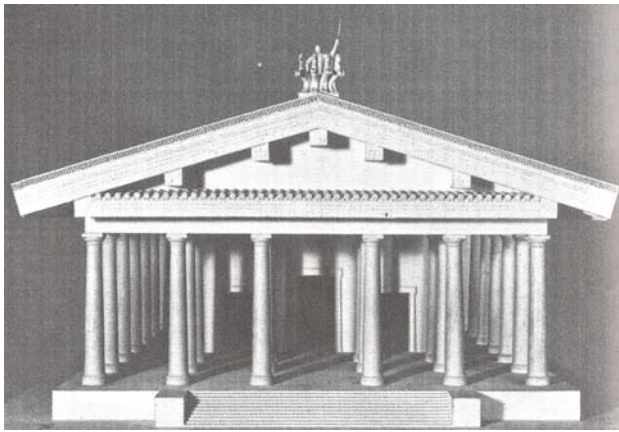

148

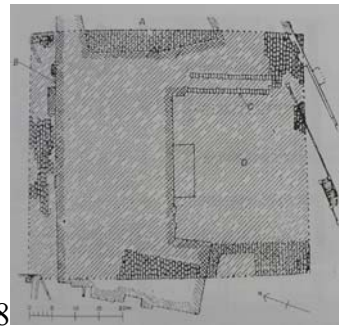

149

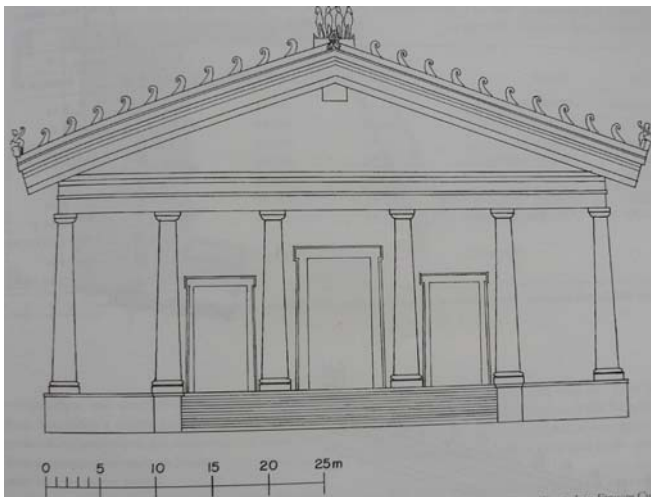

150



151

146. Axonometrie chrámu Kapitolské trojice, STAMPER 2005, s. 29, obr. 18.
 147. Chrám kapitolské trojice (dle aureliánského reliéfu), Řím, DURM 1905, s. 102, obr. 112.
 148. Rekonstrukce kapitolského chrámu, Museo di Civiltà Romana, STÜTZER 1980, s. 144, obr. 95.
 149. Půdorys kapitolského chrámu, STAMPER 2005, s. 23, obr. 11.
 150. Chrám kapitolské trojice, Řím, STAMPER 2005, s. 28, obr. 17 & s. 25, obr. 13 dle Einara Gjerstada, HEJZLAR, s. 42, obr. 15.
 151. Rekonstrukce kapitolského chrámu, STAMPER 2005, s. 7, obr. 2.



152a-d

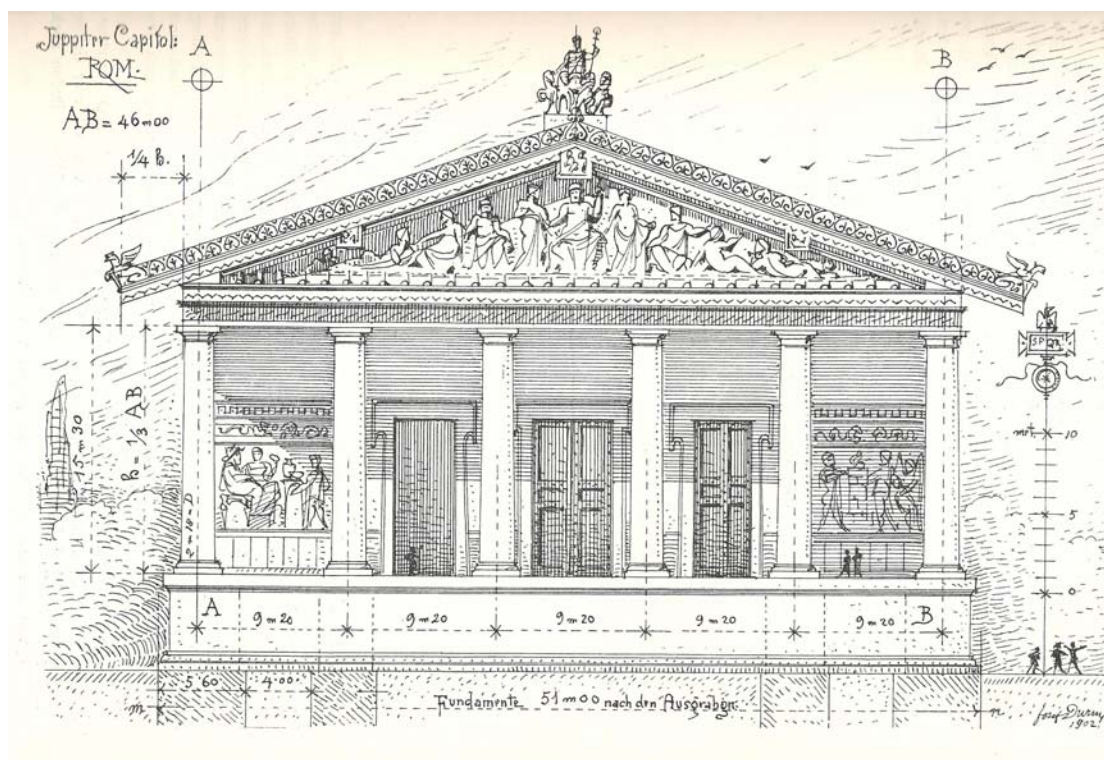

153

152a-d. Základové zdi chrámu Jupitera Optima Maxima,
 STAMPER 2005, s. 21, obr. 9, GJERSTAD 1960.

153. Chrám Jupitera Optima Maxima, DURM 1905, s. 102, obr. 113.



154

154. Mapa chrámů a svatyní v Etrurii, EDLUND-BERRY 1987, s. 32, fig. 2.